Technical Bulletin

Replacing the PIB Battery

This document provides instructions for replacing the Projector Intelligence Board (PIB) battery. If the PIB battery fails, you cannot play encrypted content.

The PIB battery replacement takes approximately 30 minutes. Christie recommends replacing the battery every five years.

Affected products

- Christie CP2210
- Christie CP2215
- Christie CP2220
- Christie CP2230
- Christie CP4220
- Christie CP4230
- Christie Solaria One
- Christie Solaria One⁺

Safety precautions



ELECTRICAL SHOCK HAZARD! Always turn off, disconnect, and disengage all power sources to the projector before servicing. Failure to comply results in death or serious injury.



Only Christie accredited service technicians are permitted to open any enclosure on the projector and only if the AC power has been fully disconnected. Failure to comply could result in minor or moderate injury.



To prevent damage by static electricity, wear an anti-static wrist strap and follow anti-static protocols when replacing the PIB battery.

Prerequisites

- Replacement PIB battery (type CR2032)
- A USB flash drive with a minimum capacity of 8GB

Replace the PIB battery

The PIB is installed in the card cage located on the operator (left) side of the projector facing the lens. This procedure describes the replacement of a PIB battery in a Christie CP2215 projector. For removal instructions that are specific to your projector model, see the projector Service Manual.



To prevent damage to the projector or personal injury, complete the procedures in the order they are written.

Backup projector settings and information

This procedure is optional, but is recommended to make sure you can recover your data if an error occurs.

1. Insert a USB flash drive into the USB port on the side of the projector touch panel controller (TPC).
2. Log on to the projector with service permissions.
3. On the TPC, tap **Menu > Service Setup > File Management**.
4. Tap **Backup**.
5. When the backup is complete, remove the USB flash drive and store it in a secure location.

Prepare the projector for service

1. If the lamp is on, tap the lamp off () icon on the projector TPC to turn it off.
2. Allow the lamp to cool for a minimum of 15 minutes.
3. Tap and hold the power off () icon to turn the projector off.
4. Disconnect the projector from AC power.
5. Disconnect any cables connected to the PIB.

Remove the PIB

1. Loosen the seven screws that secure the top lid to the projector.

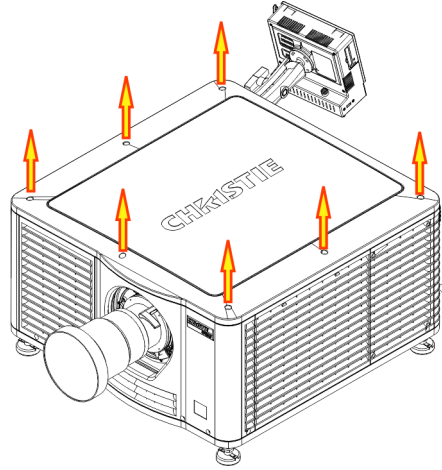

2. Lift the lid up from the rear of the projector and set it aside.
3. Unlock the high security lid with the high security key.

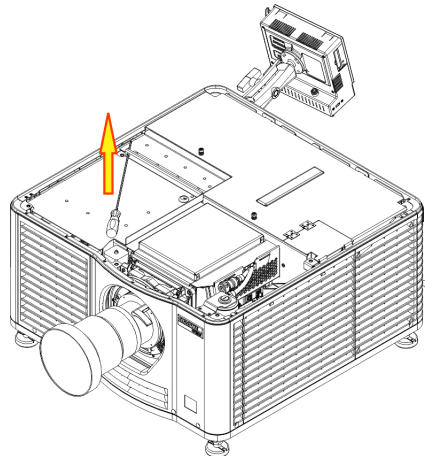

4. Lift the lid up and out and set it aside.

5. Reach into the projector and pull the lever to release the security ring.

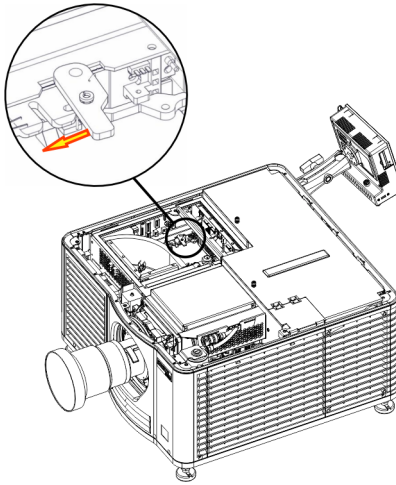

6. Lower the security ring so it is out of the way.
7. Pull the ejectors on the PIB outward.

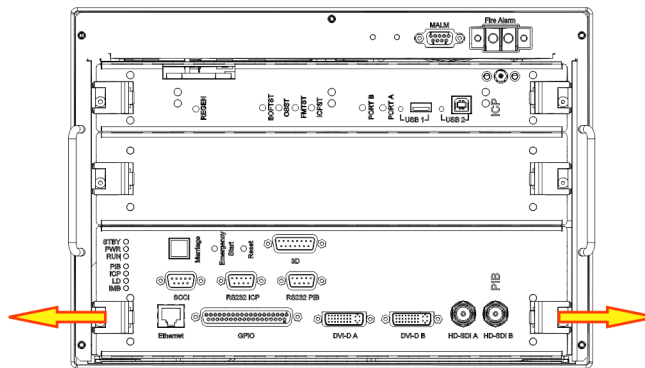

8. Pull the PIB outward out of the card cage and set it on a flat, stable surface.

Remove and replace the PIB battery

1. Insert a flat screwdriver under the battery (A) and carefully lift it upward until it separates from the retaining clip.

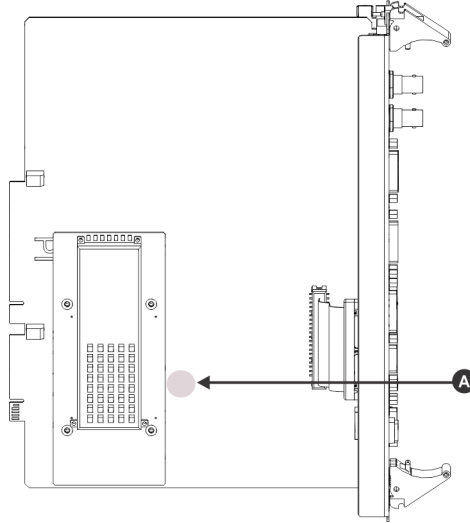

2. Remove the battery and set it aside.
Follow your local regulations for battery disposal.
3. Insert the new battery beneath the retaining clip.

Reinstall the PIB and reassemble the projector

1. Insert the PIB with even pressure into the card cage until it is firmly seated on the backplane.
2. Push the ejectors on the PIB faceplate inward to lock the PIB in position.
3. Replace the high security ring.
4. Replace the high security lid and lock it with the high security key.
5. Place the top lid on the projector and tighten the seven screws to secure it in position.
6. Reconnect the projector to AC power.
7. On the projector TPC, tap and hold the green power () icon.

Activate marriage

You must complete marriage to display encrypted content and to comply with the Digital Cinema Initiatives (DCI) specification.

1. Log on to the projector with marriage permissions.
2. Tap **Menu > Service Setup > LD Marriage**.
3. Complete the **Marriage** wizard.
4. Click **Finish**.

Restore projector settings and information

This procedure is optional. Complete this procedure if an error has occurred and you need to recover projector settings and other data.

1. Log on to the projector with service permissions.
2. Insert the USB flash drive with the backup into the USB port on the side of the projector.
3. Tap **Menu > Service Setup > File Management**.
4. Tap **Browse** to the right of the **File to restore** field.
5. Select the location of the upgrade file in the **Drive Letter** list.
6. Browse to the location of the upgrade file in the **Folder** list.
7. Tap the upgrade file and then tap **Open**.
8. Select the type of file to restore in the **Select type** list.
9. Tap **Restore**.
10. Tap **Yes**.

Technical support

North and South America: +1-800-221-8025 or tech-support@christiedigital.com

Europe, Middle East, and Africa: +44 (0) 1189 778111 or techsupport-emea@christiedigital.com

Asia Pacific: tech-asia@christiedigital.com

Christie Managed Services: +1-800-550-3061 or NOC@christiedigital.com