

FL40 / FS40 Projectors

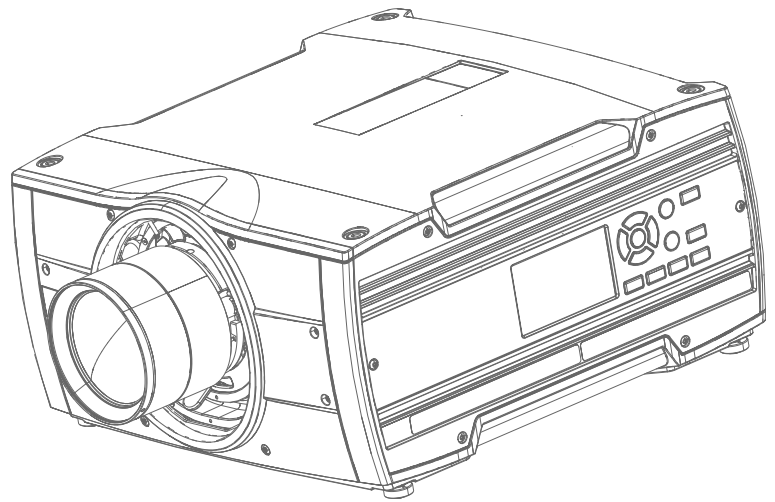

User Manual

Barco Fredrikstad AS

Haborneveien 53, N-1630 Gamle Fredrikstad, Norway
Support.fre@barco.com
www.barco.com

Registered office: Barco NV

President Kennedypark 35, 8500 Kortrijk, Belgium
www.barco.com/en/support
www.barco.com

Copyright ©

All rights reserved. No part of this document may be copied, reproduced or translated. It shall not otherwise be recorded, transmitted or stored in a retrieval system without the prior written consent of Barco.

Changes

Barco provides this manual 'as is' without warranty of any kind, either expressed or implied, including but not limited to the implied warranties or merchantability and fitness for a particular purpose. Barco may make improvements and/or changes to the product(s) and/or the program(s) described in this publication at any time without notice.

This publication could contain technical inaccuracies or typographical errors. Changes are periodically made to the information in this publication; these changes are incorporated in new editions of this publication.

The latest edition of Barco manuals can be downloaded from the Barco web site www.barco.com or from the secured Barco web site <https://www.barco.com/en/signin>.

Trademarks

Brand and product names mentioned in this manual may be trademarks, registered trademarks or copyrights of their respective holders. All brand and product names mentioned in this manual serve as comments or examples and are not to be understood as advertising for the products or their manufacturers.

Guarantee and Compensation

Barco provides a guarantee relating to perfect manufacturing as part of the legally stipulated terms of guarantee. On receipt, the purchaser must immediately inspect all delivered goods for damage incurred during transport, as well as for material and manufacturing faults Barco must be informed immediately in writing of any complaints.

The period of guarantee begins on the date of transfer of risks, in the case of special systems and software on the date of commissioning, at latest 30 days after the transfer of risks. In the event of justified notice of complaint, Barco can repair the fault or provide a replacement at its own discretion within an appropriate period. If this measure proves to be impossible or unsuccessful, the purchaser can demand a reduction in the purchase price or cancellation of the contract. All other claims, in particular those relating to compensation for direct or indirect damage, and also damage attributed to the operation of software as well as to other services provided by Barco, being a component of the system or independent service, will be deemed invalid provided the damage is not proven to be attributed to the absence of properties guaranteed in writing or due to the intent or gross negligence or part of Barco.

If the purchaser or a third party carries out modifications or repairs on goods delivered by Barco, or if the goods are handled incorrectly, in particular if the systems are operated incorrectly or if, after the transfer of risks, the goods are subject to influences not agreed upon in the contract, all guarantee claims of the purchaser will be rendered invalid. Not included in the guarantee coverage are system failures which are attributed to programs or special electronic circuitry provided by the purchaser, e.g. interfaces. Normal wear as well as normal maintenance are not subject to the guarantee provided by Barco either.

The environmental conditions as well as the servicing and maintenance regulations specified in this manual must be complied with by the customer.

Federal Communications Commission (FCC Statement)

This equipment has been tested and found to comply with the limits for a class A digital device, pursuant to Part 15 of the FCC rules. These limits are designed to provide reasonable protection against harmful interference when the equipment is operated in a commercial environment. This equipment generates, uses, and can radiate radio frequency energy and, if not installed and used in accordance with the instruction manual, may cause harmful interference to radio communications. Operation of this equipment in a residential area may cause harmful interference, in which case the user will be responsible for correcting any interference at his own expense

Changes or modifications not expressly approved by the party responsible for compliance could void the user's authority to operate the equipment

FCC responsible: Barco Inc.
3059 Premiere Parkway Suite 400
30097 Duluth GA, United States
Tel: +1 678 475 8000

Patent protection

Please refer to www.barco.com/about-barco/legal/patents

Turkey RoHS compliance



■ Türkiye Cumhuriyeti: AEEE Yönetmeliğine Uygundur.

[Republic of Turkey: In conformity with the WEEE Regulation]

Disposal Information

Waste Electrical and Electronic Equipment



■ This symbol on the product indicates that, under the European Directive 2012/19/EU governing waste from electrical and electronic equipment, this product must not be disposed of with other municipal waste. Please dispose of your waste equipment by handing it over to a designated collection point for the recycling of waste electrical and electronic equipment. To prevent possible harm to the environment or human health from uncontrolled waste disposal, please separate these items from other types of waste and recycle them responsibly to promote the sustainable reuse of material resources.

For more information about recycling of this product, please contact your local city office or your municipal waste disposal service.

For details, please visit the Barco website at: <http://www.barco.com/AboutBarco/weee>

Software License Agreement

You should carefully read the following terms and conditions before using this software. Your use of this software indicates your acceptance of this license agreement and warranty.

Terms and Conditions:

1. No redistribution of the software is allowed.
2. Reverse-Engineering. You may not reverse engineer, decompile, disassemble or alter this software product.

Disclaimer of Warranty:

This software and the accompanying files are sold “as is” and without warranties as to performance or merchantability or any other warranties whether expressed or implied. In no event shall Barco be liable for damage of any kind, loss of data, loss of profits, business interruption or other pecuniary loss arising directly or indirectly. Any liability of the seller will be exclusively limited to replacement of the product or refund of purchase price.

Patent protection

Please refer to www.barco.com/about-barco/legal/patents

Disposal of batteries in the product



■ This product contains batteries covered by the Directive 2006/66/EC which must be collected and disposed of separately from municipal waste.

If the battery contains more than the specified values of lead (Pb), mercury (Hg) or cadmium (Cd), these chemical symbols will appear below the crossed-out wheeled bin symbol.

By participating in separate collection of batteries, you will help to ensure proper disposal and to prevent potential negative effects on the environment and human health.

EMC notices

EN55032/CISPR32 Class A MME (MultiMedia Equipment)

Warning : This equipment is compliant with Class A of CISPR 32. In a residential environment this equipment may cause radio interference.

GB/T 9254 Class A ITE (Information Technology Equipment)

Warning : This is a class A product. In a domestic environment this product may cause radio interference in which case the user may be required to take adequate measures.

BSMI Taiwan Class A statement:

警告使用者：此為甲類資訊技術設備，於居住環境中使用，可能會造成射頻擾動，在此情況下，使用者會被要求採取某些適當的對策。

EN55032/CISPR32 Class A MME (MultiMedia Equipment)

Warning : This equipment is compliant with Class A of CISPR 32. In a residential environment this equipment may cause radio interference.

Class A ITE (Information Technology Equipment)

Warning : This is a class A product. In a domestic environment this product may cause radio interference in which case the user may be required to take adequate measures.

警告使用者：此為甲類資訊技術設備，於居住環境中使用時，可能會造成射頻擾動，在此種情況下，使用者會被要求採取某些適當的對策。

Table of contents

1 Safety and environmental information	11
1.1 General considerations	12
1.2 Important safety instructions	12
1.3 Safety Symbols FL40 / FS40	15
1.4 Location of labels	16
1.5 Disposal Information	16
1.6 Turkey RoHS compliance	16
1.7 China RoHS compliance	17
1.8 Taiwan RoHS compliance	18
1.9 Contact information	19
1.10 Production Address	19
1.11 Product Info	19
1.12 Statement	20
2 Getting to know the projector	21
2.1 Location of the main exterior components	22
2.2 Service and maintenance	23
2.3 Power on / Standby button backlight indications	23
2.4 LCD Panel	23
2.4.1 LCD panel general	23
2.4.2 OSD Menu mode	24
2.4.3 LCD functionality in Ready Mode	24
2.5 Local keypad	24
2.6 Remote control	25
2.6.1 Remote control, battery installation	25
2.6.2 Remote control, protocol setup	26
2.6.3 Functionality overview	27
2.6.4 Remote control, on/off button	28
2.6.5 Function of the RGB filter button	28
2.6.6 Enable / Disable Remote Control	28
2.6.7 Wired RC connection	29
2.7 Projector Address	29
2.7.1 Controlling the projector	29
2.8 Connector panel	30
3 Lenses	31
3.1 Approved lenses	32
3.2 Replace a lens	32
3.3 Locking the lens position	34
4 Physical installation	37

4.1	Installation process	38
4.2	Installation conditions	38
4.3	Initial inspection	39
4.4	Positioning the projector	39
4.5	Mounting the projector, general considerations	40
4.6	Mounting surfaces	41
4.7	Projector safe attachment points	41
4.8	Removal of the front cover	43
4.9	Throw distance	43
4.10	Scheimpflug (Boresight) adjustment	46
4.11	Scheimpflug adjustment procedure	47
5	Getting the projector started	51
5.1	Projector source and control connections	52
5.1.1	Input source connections	52
5.1.2	Connector Specifications	52
5.1.2.1	DVI-I	52
5.1.2.2	Display Port 1.2	52
5.1.2.3	HDMI 2.0	53
5.1.2.4	HDBase T	53
5.1.3	Control Interfaces	54
5.1.3.1	RS-232	54
5.1.3.2	LAN/Ethernet	54
5.1.3.3	USB-A port	54
5.2	Power up the projector	55
5.3	Power down the projector	55
5.4	Power mode transitions	55
5.4.1	General	55
5.4.2	Power on projector	56
5.4.3	Going from READY to ON	56
5.4.4	Going from ON to READY	56
5.4.5	Going from READY to ECO standby	57
5.4.6	Going from ECO to ON	57
5.4.7	Wake On LAN (WOL)	57
5.5	Power modes	57
5.6	Customize projector settings	57
5.7	User interface	57
5.7.1	On Screen Display (OSD)	58
6	Source menu	59
6.1	Connector selection	60
6.2	Connector settings	60
6.3	Using dual inputs	62
7	Image menu	65
7.1	Contrast	67
7.2	Brightness	67
7.3	Saturation	67
7.4	Sharpness	68
7.5	Gamma adjustment	68
7.6	Gamma Types	69
7.6.1	Predefined Gamma types	69
7.6.2	DICOM Gamma	69
7.7	Digital Zoom Shift	70
7.7.1	Digital Zoom	71

7.7.2	Digital Shift.....	72
7.8	Advanced image adjustments	73
7.8.1	P7 Realcolor	73
7.8.2	Edit the RealColor presets	74
7.8.3	Output resolution 4K	76
7.8.4	Smear reduction	76
7.8.5	Brilliant color	76
7.8.6	Displaying HDR content– Perceptual Quantizer (PQ).....	77
7.8.7	HDR Status	77
7.8.8	Nightvision	78
8	Installation menu	79
8.1	IR / Night vision functionality	80
8.2	Lens	82
8.2.1	Zoom / Focus	82
8.2.2	Shift.....	83
8.2.3	Shift to center	83
8.2.4	Iris	84
8.3	Orientation	85
8.4	Scaling modes	86
8.5	Warping	89
8.5.1	About warping	89
8.5.2	Warping – On/Off.....	89
8.5.3	Warping – Screen size	90
8.5.4	Warp – 4 Corners adjustment	92
8.5.5	Warping – Bow.....	93
8.5.6	Warping – Warp files	96
8.5.7	Warping – Latency control in a multi projector setup	98
8.6	Blending	99
8.6.1	Basic blend	99
8.6.2	Set up the system	100
8.6.3	Adjustment procedure	100
8.6.4	Black level adjustment	101
8.6.5	Black level files.....	103
8.6.6	RGB Adjustment.....	104
8.6.7	Blend files.....	105
8.6.8	Advanced blend	106
8.7	Illumination	106
8.8	CLO — constant light output	107
8.9	Display setup.....	108
8.9.1	IG Pixel shift.....	108
8.9.2	AotoStereo (3D) Setup	109
9	Profiles	111
9.1	Profiles setup parameters	112
9.2	Enable Profiles	113
10	System settings menu	117
10.1	Communication	118
10.2	Apply a menu theme	118
10.3	Units	119
10.4	Standby ECO	119
10.5	Maintenance	120
10.6	Reset.....	120
10.7	Lens features.....	122

10.8	Controlling the backlight of the LCD Display	122
11	Status menu.....	125
11.1	Status menu overview.....	126
12	3D.....	129
12.1	Setup 3D mode.....	130
13	Upgrade projector firmware.....	133
13.1	Upgrade procedure.....	134
14	User maintenance — Cleaning the projector.....	135
14.1	Projector lenses.....	136
14.2	Projector cabinet.....	136
14.3	Filters.....	136
Index.....	137

Safety and environmental information

1

About

Read this chapter thoroughly before attempting to install or operate the projector.

To prevent personal injury to users or physical damage to the projector while installing and using your projector, ensure that you understand and follow all safety guidelines, instructions and warnings included in this chapter and this manual.

Clarification of the term FL40 series used in this document

Use in this document of the term, FL40 , means that the content is applicable for the following products:

- FL40 - WU
- FL40 - 4K
- FS40 - WU
- FS40 - 4K

Defining the FL40 platform

The FL40 series products in general, are all products within the Barco GP5 platform

1.1 General considerations

Notice on optical radiation FL40 Series

- Do not stare into Beam.
- This projector is Risk Group 2 (RG2) according to IEC EN 62471-5.
- Any operation or adjustment not specifically instructed by the user's guide creates the risk of hazardous light radiation exposure.
- Do not open or disassemble the projector as this may cause danger to unauthorized personnel

General safety instructions

- This product contains no user serviceable parts. Attempts to modify/replace mechanics or electronics inside the housing or compartments will violate any warranties and may be hazardous.
- Do not stare into beam when the projector is on. The bright light may result in permanent eye damage.
- Before operating this equipment please read this manual thoroughly and retain it for future reference.
- Installation and preliminary adjustments should be performed by properly trained and qualified personnel.
- All warnings on the projector and in the documentation manuals must be adhered to.
- All instructions for operating and use of this equipment must be followed precisely.
- All local installation codes should be adhered to.

Notice on safety

This equipment is built in accordance with the requirements of the international safety standards IEC60950-1, as basis for National safety regulation world wide. The safety standard covers information technology equipment including electrical business equipment intended to operate in "normal" environments (offices and homes). This safety standard imposes important requirements on the use of safety critical components, materials and insulation, in order to protect the user or operator against risk of electric shock and energy hazard and having access to live parts. Safety standards also impose limits to the internal and external temperature rises, radiation levels, mechanical stability and strength, enclosure construction and protection against the risk of fire. Simulated single fault condition testing reduce the risk of hazards and contribute to ensure the safety of the equipment to the user even when the equipment's normal operation fails.

Users definition

Throughout this manual, the term SERVICE PERSONNEL refers to Barco authorized persons having appropriate technical training and experience necessary to be knowledgeable of potential hazards to which they are exposed (including, but not limited to HIGH VOLTAGE ELECTRIC and ELECTRONIC CIRCUITRY and HIGH BRIGHTNESS PROJECTORS) in performing a task, and of measures to minimize the potential risk to themselves or other persons. Only Barco authorized SERVICE PERSONNEL, knowledgeable of such risks, are allowed to perform service functions inside the product enclosure. The term USER and OPERATOR refers to any person other than SERVICE PERSONNEL.

1.2 Important safety instructions

To prevent the risk of electrical shock

- This product should be operated from a mono phase AC power source.
- This apparatus must be grounded (earthed) via the supplied 3 conductor AC power cable. If none of the supplied power cables are the correct one, consult your dealer.
If you are unable to insert the plug into the outlet, contact your electrician to replace your obsolete outlet.
Do not defeat the purpose of the grounding-type plug.
Never use 2- wire power cords, as this is dangerous and could lead to electrical shock. Always use a power connector with a ground terminal.
- Do not allow anything to rest on the power cord. Do not locate this product where persons will walk on the cord. To disconnect the cord, pull it out by the plug. Never pull the cord itself.
- Ensure that the main power cord complies with the national regulations at the site where the equipment is used.
- Do not use unauthorized replacements

- Do not operate the projector with a damaged cord. Replace the cord.
Do not operate the projector if the projector has been dropped or damaged - until it has been examined and approved for operation by a qualified service technician.
- Position the cord so that it will not be tripped over, pulled, or contact hot surfaces.
- If an extension cord is necessary, a cord with a current rating at least equal to that of the projector should be used. A cord rated for less amperage than the projector may overheat.
- Never push objects of any kind into this product through cabinet slots as they may touch dangerous voltage points or short out parts that could result in a risk of fire or electrical shock.
- Make sure that no objects enter into the vents and openings of the set.
- Do not expose this projector to rain or moisture.
- The projector is designed for indoor use only. Never operate the unit outdoors.
- Do not immerse or expose this projector in water or other liquids.
- Do not spill liquid of any kind on this projector.
- Should any liquid or solid object fall into the cabinet, unplug the set and have it checked by qualified service personnel before resuming operations.
- Do not disassemble this projector, always take it to an authorized trained service person when service or repair work is required.
- Do not use an accessory attachment which is not recommended by the manufacturer.
- Lightning - For added protection for this video product during a lightning storm, or when it is left unattended and unused for long periods of time, unplug it from the wall outlet. This will prevent damage to the device due to lightning and AC power-line surges.

To prevent personal injury

- To prevent injury and physical damage, always read this manual and all labels on the system before connecting to the wall outlet or adjusting the projector.
- To prevent injury, take note of the weight of the projector.
- To prevent injury, ensure that the lens and all covers are correctly installed. See installation procedures.
- Warning: high intensity light beam. NEVER look into the lens! High luminance could result in damage to the eye.
- Always switch off the projector and disconnect from the mains power supply before attempting to remove any of the projector covers or access parts inside the projector.
- This product contains no user serviceable parts. Attempts to modify/replace mechanics or electronics inside the housing or compartments will violate any warranties and may be hazardous.
- Do not place this equipment on an unstable cart, stand, or table. The product may fall, causing serious damage to it and possible injury to the user.
- Only place the projector on a stable surface, or mount it securely using an approved ceiling-mount.

To prevent fire hazard

- Barco projection products are designed and manufactured to meet the most stringent safety regulations. This projector radiates heat on its external surfaces and from ventilation ducts during normal operation, which is both normal and safe. Exposing flammable or combustible materials into close proximity of this projector could result in the spontaneous ignition of that material, resulting in a fire. For this reason, it is absolutely necessary to leave an "exclusion zone" around all external surfaces of the projector whereby no flammable or combustible materials are present.
- Do not place flammable or combustible materials near the projector!
- Caution! Hot air is exhausted from the rear vent. Do not place objects that are sensitive to heat nearer than 25 cm (10") to the exhaust vent.
- Slots and openings in this equipment are provided for ventilation. To ensure reliable operation of the projector and to protect it from overheating, these openings must not be blocked or covered.
- The openings should never be blocked by placing the projector too close to walls, or other similar surface. Allow for sufficient distance to walls and ceilings to avoid overheating. Minimum safety distance to the exhaust area of the unit must not be less than 25 cm (10") and to the intake area, not less than 25 cm (10").
- This projector should never be placed near or over a radiator or heat register.
- This projector should not be placed in a built-in installation or enclosure unless proper ventilation is provided.
- Do not cover the projector or the lens with any material while the projector is in operation. Keep flammable and combustible materials away from the projector at all times.
- Mount the projector in a well-ventilated area away from sources of ignition and out of direct sun light. Always allow ample airflow through the projector.

- Never expose the projector to rain or moisture. In the event of fire, use sand, CO2 or dry powder fire extinguishers.
- Never use water on an electrical fire.
- Always have service performed on this projector by authorized Barco service personnel. Always insist on genuine Barco replacement parts. Never use non-Barco replacement parts as they may degrade the safety of this projector.
- Projection rooms must be well ventilated or cooled in order to avoid heat buildup.
- Let the projector cool down completely before storing. Remove cord from the projector when storing.

To prevent projector damage

- To ensure correct airflow is maintained, the projector should only be operated when all of its covers in place. The exception from this is the front cover, that can be removed to give access to multiple anchor points. See User Guide for more detailed info regarding this issue.
- Always remove lens cap before switching on the projector. If the lens cap is not removed, it may melt due to the high energy light emitted through the lens. Melting the lens cap may permanently damage the surface of the projection lens
- Only connect the projector to signal sources and voltages as described in the technical specification. Connecting to unspecified signal sources or voltages may lead to malfunction and permanent damage of the unit.
- To ensure correct airflow is maintained, it should only be operated when all of its covers are in place.
- The projector must always be installed in a manner which ensures free flow of air into its air inlets and unimpeded evacuation of the hot air from its cooling system.
- Slots and openings in the cabinet are provided for ventilation. To ensure reliable operation of the product and to protect it from overheating, these openings must not be blocked or covered. The openings should never be blocked by placing the product on a bed, sofa, rug, or other similar surface. This product should never be placed near or over a radiator or heat register. The device should not be placed in a built-in installation or enclosure unless proper ventilation is provided. Ensure that nothing can be spilled on, or dropped inside the projector. If this does happen, switch off and unplug the mains supply immediately. Do not operate the projector again until it has been checked by Barco authorized service personnel.
- Do not block the projector cooling fans or free air movement around the projector. Minimum safety distance to the exhaust area of the unit must not be less than 25 cm (10") and to the intake area, not less than 25 cm (10").
- Do not use this equipment near water.
- Do not operate the projector outside its temperature and humidity specifications as this may result in overheating and malfunction.
- Never place the projector in direct sun light. Sun light on the lens can severely damage the Digital Mirror Devices™ in which case there is a loss of warranty.
- Save the original shipping carton and packing material. They will come in handy if you ever have to ship your equipment. For maximum protection, repack your set as it was originally packed at the factory.
- Unplug this product from the wall outlet before cleaning. Do not use liquid cleaners or aerosol cleaners. Use a damp cloth for cleaning. Never use strong solvents, such as thinner or benzene, or abrasive cleaners, since these will damage the cabinet. Stubborn stains may be removed with a cloth lightly dampened with mild detergent solution.
- To ensure the highest optical performance and resolution, the projection lenses are specially treated with an anti-reflective coating, therefore, avoid touching the lens. To remove dust on the lens, use a soft dry cloth. Do not use a damp cloth, detergent solution, or thinner.

On servicing





- Do not attempt to service this product yourself, as opening or removing covers may expose you to dangerous voltage potentials and risk of electric shock.
- Refer all servicing to Barco authorized repair centers.
- Attempts to alter the factory-set internal controls or to change other control settings not specially discussed in this manual can lead to permanent damage to the projector and cancellation of the warranty.
- Unplug this product from the wall outlet and refer servicing to Barco authorized service personnel or technicians under the following conditions:
 - If liquid has been spilled into the equipment.
 - If the product has been exposed to rain or water.
 - If the product does not operate normally when the operating instructions are followed. Adjust only those controls that are covered by the operating instructions since improper adjustment of the other controls

may result in damage and will often require extensive work by a qualified technician to restore the product to normal operation.

- If the product has been dropped or the cabinet has been damaged.
- If the product exhibits a distinct change in performance, indicating a need for service.
- When the power cord or plug is damaged or frayed.
- Replacement parts: When replacement parts are required, be sure the service technician has used original Barco replacement parts. Unauthorized substitutions may result in degraded performance and reliability, fire, electric shock or other hazards. Unauthorized substitutions may void warranty.
- Safety check: Upon completion of any service or repairs to this projector, ask the service technician to perform safety checks to determine that the product is in proper operating condition.

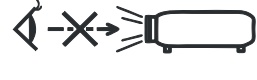
1.3 Safety Symbols FL40 / FS40

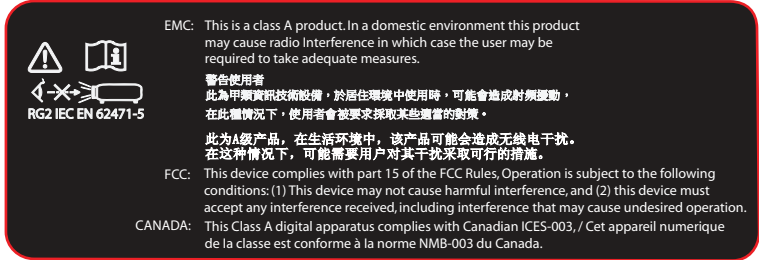
Description of safety symbols used in product documentation or on product.

Image	Description
	<p>Refer to user manual for further information!</p>
	<p>Caution! Do not stare into beam, RG2 product.</p>
	<p>No telephone! Do not connect to telephone lines.</p>
	<p>FL40 EMC Label</p>
	<p>FL40 RG2 Label</p>

1.4 Location of labels

Label positions

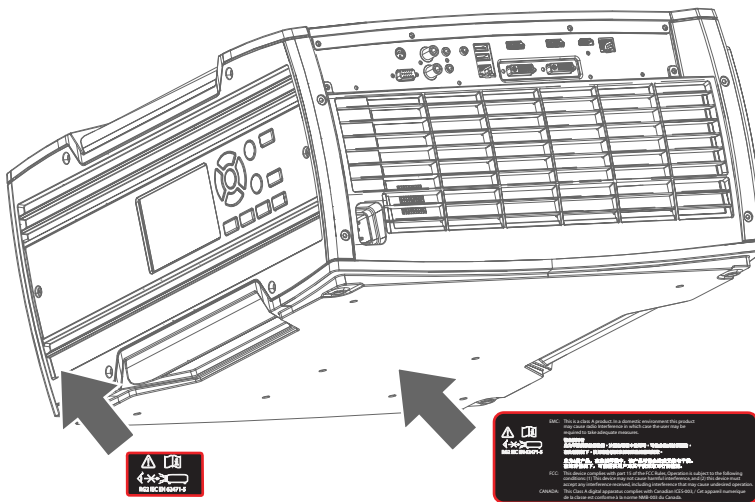

Image 1-1: Location of RG2 and EMC label.

1.5 Disposal Information

Disposal Information

Waste Electrical and Electronic Equipment



■ This symbol on the product indicates that, under the European Directive 2012/19/EU governing waste from electrical and electronic equipment, this product must not be disposed of with other municipal waste. Please dispose of your waste equipment by handing it over to a designated collection point for the recycling of waste electrical and electronic equipment. To prevent possible harm to the environment or human health from uncontrolled waste disposal, please separate these items from other types of waste and recycle them responsibly to promote the sustainable reuse of material resources.

For more information about recycling of this product, please contact your local city office or your municipal waste disposal service.

For details, please visit the Barco website at: <http://www.barco.com/AboutBarco/weee>

WEEE Information

This product conforms to all requirements of the EU Directive on waste electrical and electronic equipment (WEEE). This product shall be recycled properly. It can be disassembled to facilitate proper recycling of its individual parts.

Consult your dealer or relevant public authority regarding drop-off points for collection of WEEE. For details, please visit the Barco website at: <http://www.barco.com/en/AboutBarco/weee>.

1.6 Turkey RoHS compliance

Turkey RoHS compliance



■ Türkiye Cumhuriyeti: AEEE Yönetmeliğine Uygundur.

[Republic of Turkey: In conformity with the WEEE Regulation]

1.7 China RoHS compliance

中国大陆 RoHS (Information for China ROHS compliance)

根据中国大陆《电器电子产品有害物质限制使用管理办法》（也称为中国大陆RoHS），以下部分列出了Barco产品中可能包含的有毒和/或有害物质的名称和含量。中国大陆RoHS指令包含在中国信息产业部MCV标准：“电子信息产品中有毒物质的限量要求”中。

According to the “Management Methods for the Restriction of the Use of Hazardous Substances in Electrical and Electronic Products” (Also called RoHS of Chinese Mainland), the table below lists the names and contents of toxic and/or hazardous substances that Barco’s product may contain. The RoHS of Chinese Mainland is included in the MCV standard of the Ministry of Information Industry of China, in the section “Limit Requirements of toxic substances in Electronic Information Products”.

零件项目(名称) Component name	有毒有害物质或元素 Hazardous substances and elements					
	铅 (Pb)	汞 (Hg)	镉 (Cd)	六价铬 (Cr6+)	多溴联苯 (PBB)	多溴二苯 醚 (PBDE)
印制电路配件 Printed Circuit Assemblies	X	O	X	O	O	O
外接电(线)缆 External Cables	X	O	O	O	O	O
内部线路 Internal wiring	X	O	O	O	O	O
镜头支架 Lensholder	X	O	O	O	O	O
螺帽,螺钉(栓),螺旋(钉),垫圈, 紧固件 Nuts, bolts, screws, washers, Fasteners	X	O	O	O	O	O
电源供应器 Power Supply Unit	X	O	O	O	O	O
风扇 Fan	X	O	O	O	O	O
附電池遙控器 Remote control	X	O	O	O	O	O

本表格依据SJ/T 11364的规定编制

This table is prepared in accordance with the provisions of SJ/T 11364.

O: 表示该有毒有害物质在该部件所有均质材料中的含量均在 GB/T 26572 标准规定的限量要求以下。

O: Indicates that this toxic or hazardous substance contained in all of the homogeneous materials for this part is below the limit requirement in GB/T 26572.

X: 表示该有毒有害物质至少在该部件的某一均质材料中的含量超出 GB/T 26572 标准规定的限量要求。

X: Indicates that this toxic or hazardous substance contained in at least one of the homogeneous materials used for this part is above the limit requirement in GB/T 26572.



在中国大陆销售的相应电子信息产品（EIP）都必须遵照中国大陆《电子电气产品有害物质限制使用标识要求》标准贴上环保使用期限（EFUP）标签。Barco产品所采用的EFUP标签（请参阅实例，徽标内部的编号使用于指定产品）基于中国大陆的《电子信息产品环保使用期限通则》标准。

All Electronic Information Products (EIP) that are sold within Chinese Mainland must comply with the “Marking for the restriction of the use of hazardous substances in electrical and electronic product” of Chinese Mainland, marked with the Environmental Friendly Use Period (EFUP) logo. The number inside the EFUP logo that Barco uses (please refer to the photo) is based on the “General guidelines of environment-friendly use period of electronic information products” of Chinese Mainland.

1.8 Taiwan RoHS compliance

限用物質含有情況標示聲明書 (Declaration of the Presence Condition of the Restricted Substances Marking)

單元 Unit	限用物質及其化學符號 Restricted substances and its chemical symbols					
	鉛 Lead (Pb)	汞 Mercury (Hg)	鎘 Cadmium (Cd)	六價鉻 Hexavalent chromium (Cr6+)	多溴聯苯 Polybrominated biphenyls (PBB)	多溴二苯醚 Polybrominated diphenyl ethers (PBDE)
印製電路板配件 Printed Circuit Assemblies	—	○	—	○	○	○
外接電 (線) 纜 External Cables	—	○	○	○	○	○
內部線路 Internal wiring	—	○	○	○	○	○
鏡頭支架 Lensholder	—	○	○	○	○	○
螺絲組件 Nuts, bolts, screws, washers, Fasteners	—	○	○	○	○	○
電源供應器 Power Supply Unit	—	○	○	○	○	○
風扇 Fan	—	○	○	○	○	○
遙控器 Remote control	—	○	○	○	○	○
備考1. “超出0.1 wt %” 及 “超出0.01 wt %” 係指限用物質之百分比含量超出百分比含量基準值。 Note 1 : “Exceeding 0.1 wt %” and “exceeding 0.01 wt %” indicate that the percentage content of the restricted substance exceeds the reference percentage value of presence condition. 備考2. “○” 係指該項限用物質之百分比含量未超出百分比含量基準值。 Note 2 : “○” indicates that the percentage content of the restricted substance does not exceed the percentage of reference value of presence. 備考3. “—” 係指該項限用物質為排除項目。 Note 3 : The “—” indicates that the restricted substance corresponds to the exemption.						

備註: 此RoHS表格適用於以下產品型號: GP5

Hint: This RoHS table is suitable for following models: GP5

1.9 Contact information

Barco contact information

Registered office address: President Kennedypark 35, 8500 Kortrijk, Belgium

Contact address: Beneluxpark 21, 8500 Kortrijk, Belgium

Contact address (for Taiwan) :

公司名稱 (Company Name) : 巴可股份有限公司

地址 (Address) : 新北市板橋區新站路16號33樓

傳真 (Fax) : 02-7715 0298

電話 (Tel) : 02-7715 0299

E-mail : service.taiwan@barco.com

Importers contact information

To find your local importer, contact Barco directly or one of Barco's regional offices via the contact information given on Barco's web site, www.barco.com.

Contact information Norway factory

Barco Fredrikstad as

Habornveien 53, N1630 Gamle Fredrikstad, Norway

Phone: +476930 4550

Support:Support.fre@barco.com

1.10 Production Address

Factories

Barco NV (BELGIUM)

President Kennedypark 35 , B-8500 Kortrijk

Barco Fredrikstad AS (NORWAY)

Habornveien 53, N-1630 Gamle Fredrikstad

1.11 Product Info

Product info



Image 1-2

product name 產品名稱:

projector 投影機

model 型號: GP5

1.12 Statement

EN55032/CISPR32 Class A MME (MultiMedia Equipment)

Warning : This equipment is compliant with Class A of CISPR 32. In a residential environment this equipment may cause radio interference.

Class A ITE (Information Technology Equipment)

Warning : This is a class A product. In a domestic environment this product may cause radio interference in which case the user may be required to take adequate measures.

警告使用者: 此為甲類資訊技術設備，於居住環境中使用時，可能會造成射頻擾動，在此種情況下，使用者會被要求採取某些適當的對策。

Getting to know the projector.

2

Overview

- Location of the main exterior components.
- Service and maintenance
- Power on / Standby button backlight indications
- LCD Panel
- Local keypad
- Remote control
- Projector Address
- Connector panel

2.1 Location of the main exterior components.

Defining of surfaces

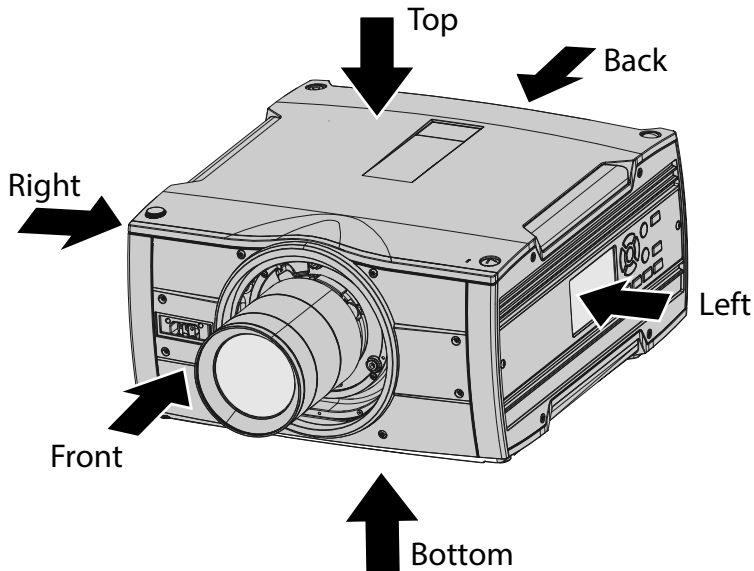

Image 2-1

Main Components

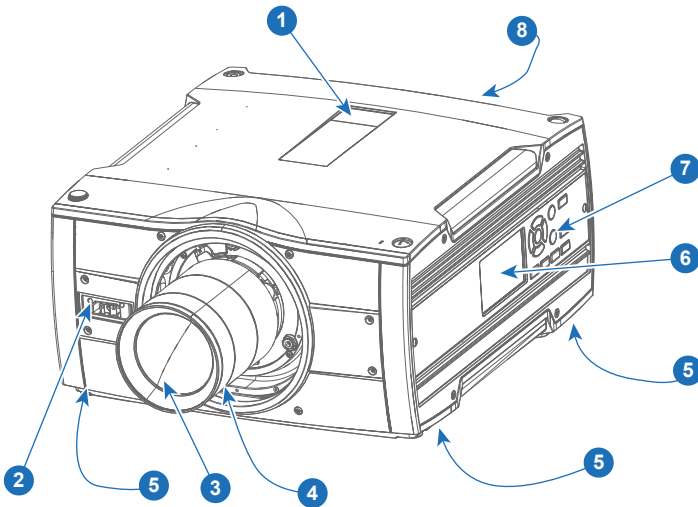

Image 2-2

Main exterior components matrix			
Item Number	Component	Item Number	Component
1	IR Receiver top	5	Projector feet (x4)
2	IR Receiver front	6	LCD Panel
3	Lens	7	Key Pad
4	Lens release handle	8	Back Panel / Connectors

2.2 Service and maintenance

General

The FL40 / FS 40 projectors does not have any user serviceable parts.

All service tasks must only be carried out by the manufacturer, or a Barco authorized service personnel or Barco technicians.

2.3 Power on / Standby button backlight indications

Indicator

In addition to the LED indicator, the projector also displays status indications in the backlight of the Power / Standby button.

The table below shows the details regarding this indications.

Operating Status	Indication Color / Behavior
On (active)	Blue
Wait on	Blue flashing
Standby (off)	White
Wait	White short flashing
Overheating	Red flashing
Configure/upgrade	White fast flashing
Standby ECO	White heartbeat
Software Lockup	Red

2.4 LCD Panel

2.4.1 LCD panel general

About

The LCD panel (See chapter 2.6, Local Keypad) is located on the right side of the projector, and has two modes of indication; Mirror of the OSD, and Information display.

Toggle between the two indications by using the Menu button on the keypad, or on the remote control

1. When mirroring the OSD, the LCD showing the menus and adjustment information.
2. When in information mode, showing this Information regarding the status of the projector:
 - Projector status
 - Network address and status
 - Active source
 - Illumination Status
 - Current firmware version
 - Active functions (Enabled Functions).
 - Display Info, including Transport delay
 - Environment Info.

Use the navigation keys (arrows) to scroll the information menu.

When in information mode, press OK (confirm selection (✓)) to see notifications and warnings.

The LCD Display will fade out 15 seconds after the last key operation.

2.4.2 OSD Menu mode

About.

This is the projector setup menus, explained in detail in their own chapters in this manual. (Source menu, Image menu, Installation menu, System Settings menu, Status menu).

2.4.3 LCD functionality in Ready Mode

When the projector is in Ready mode, it is possible to activate and navigate in the projectors menu on the LCD display, in order to set or check values and settings before the lamp is switched on.

Ready mode is enabled either when the power cable is connected (after the startup sequence), or when pressing the Power Off for 3 seconds when the projector is in On mode. See chapter 5.4 Power Mode Transitions for a graphic presentation of the ready mode.

Procedure

When in ready mode, press the Menu button either on the remote control, or the keypad to enter the menus. Navigate by using the arrow and OK keys, either on the remote control or the keypad.

2.5 Local keypad

About

The Keypad gives direct access to several functions, in addition to access to the menu system. The keypad and remote control functions are equal.

The keypad has a back light that can be switched on and off manually. The light turns off automatically after a preset time.

The Standby key is equipped with white, blue and red backlight depending on the status of the projector. See table in “Power on / Standby button backlight indications”, page 23 for info regarding this.



Image 2-3

Item No.	Name	Description
1	LCD Display	Shows Projector status and navigation menu.
2	Navigation keys	Navigation arrows (up, down, left, right), confirm selection (✓)
3	Menu button	Toggle between OSD / Information menu.
4	Standby	Power on / standby

Item No.	Name	Description
5	Back	Undo action / back to previous screen.
6	OSD ON/OFF	Deactivate the On Screen Display (OSD). Only critical warnings will be displayed.
7	Input	Shortcut to input source menu on LCD. Use navigation keys to select and enable input.
8	Shutter	Enable and disable the lens shutter function. This is not a mechanical shutter, but it toggles the light source on and off. Backlight is red when the shutter are enabled.
9	Test Patterns	Shortcut to test pattern menu on LCD. Use navigation keys to select the desired pattern.
10	Lens	Shortcut to lens function. A test pattern displays on the OSD. LCD screen displays the navigation keys to manage and confirm actions.

2.6 Remote control

Overview

- Remote control, battery installation
- Remote control, protocol setup
- Functionality overview
- Remote control, on/off button
- Function of the RGB filter button
- Enable / Disable Remote Control
- Wired RC connection

2.6.1 Remote control, battery installation

Where to find the batteries for the remote control ?

The batteries are not placed in the remote control unit to avoid control operation in its package, resulting in a shorter battery life time. At delivery the batteries can be found in a separated bag attached to the remote control unit. Before using your remote control, install the batteries first.

How to install

1. Push the battery cover tab with the fingernail a little backwards (1) and pull, at the same time, the cover upwards (2).

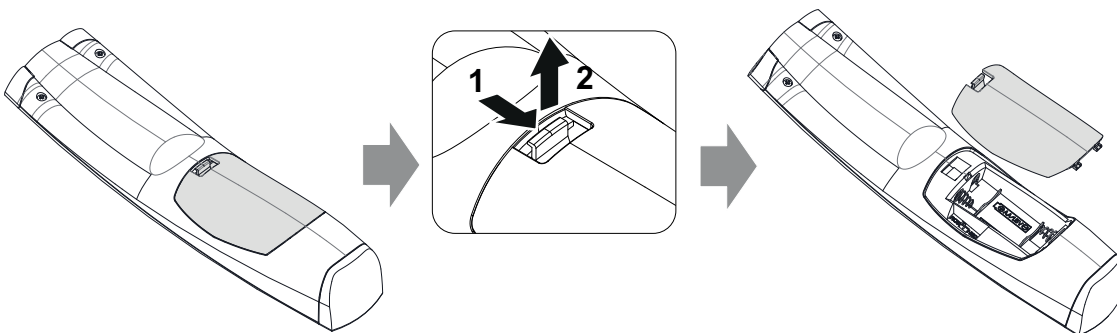



Image 2-4

2. Insert the two AA size batteries, making sure the polarities match the + and - marks inside the battery compartment.

 *Tip:* Use alkaline batteries for optimum range and life time.

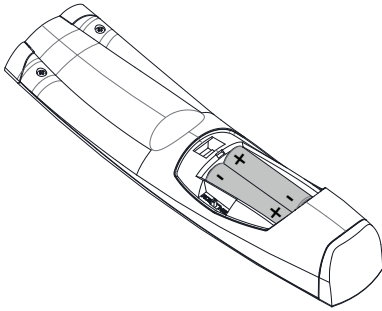

Image 2-5

3. Insert (1) both lower tabs of the battery cover in the gaps at the bottom of the remote control, and press (2) the cover until it clicks in place.

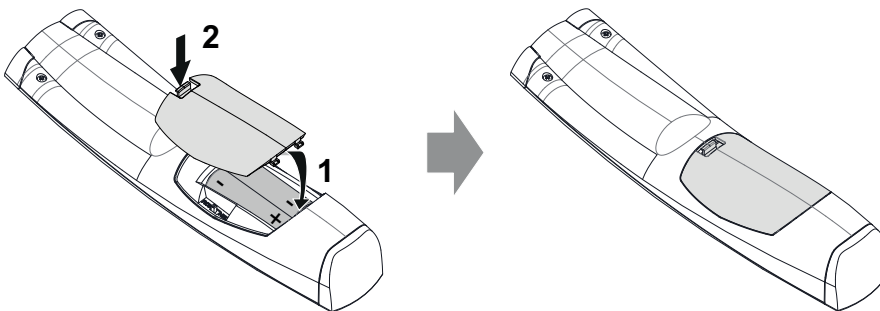

Image 2-6



When replacing batteries, the broadcast address of the RCU will be reset to its default value '0'.



CAUTION: Replace with the correct battery type. Use two AA size batteries

2.6.2 Remote control, protocol setup

About the used protocol

The protocol is the code send out by the remote control when a button is pressed. Depending on this code, the projector can decode the signals. The remote control can be used with two different protocols, RC5 and NEC. Depending on the projector to control, the remote control can be switched between these protocols.

Which protocol to use

- The **NEC** protocol have to be used for Barco projectors based on the Pulse platform: Loki, Balder, F70, F80, F90, HDX 4K, UDX, ...
- The **RC5** protocol have to be use all other Barco projectors: HDX W, HDF W, HDQ 2K, ...

How to set

1. Remove the cover. For more info on how to remove, see “Remote control, battery installation”, page 25.
2. Place the switch in the NEC position.

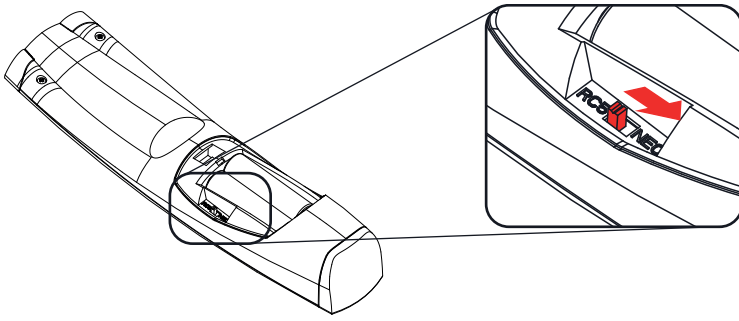

Image 2-7

Remark with RC5 protocol

Not all buttons of the Pulse RCU are one-to-one compatible with the legacy Barco RCU. Button pairs SHUTTER open/close and POWER on/off emit the same code (per pair) when in RC5 mode, because the legacy RCU's only had 1 button for Shutter and 1 button for Standby.

2.6.3 Functionality overview

Remote Control Unit buttons

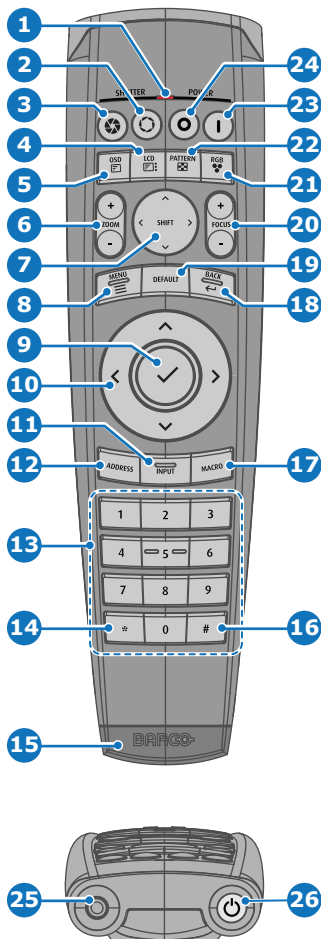

- | | |
|-------------------------------------|---|
| 1 Button pressed indicator. | 14 Backspace (while entering values) |
| 2 Shutter Open. | 15 XLR connector. |
| 3 Shutter Close. | 16 Decimal mark (while entering values) |
| 4 Touch Panel On/Off. (Not in use). | 17 Macro button. (Not in use) |
| 5 OSD On/Off. | 18 Menu Back. |
| 6 Lens Zoom. | 19 Default button. (Not in use). |
| 7 Lens Shift. | 20 Lens Focus. |
| 8 Menu Activation. | 21 RGB Button. |
| 9 Menu Selection, OK button. | 22 Test Patterns. |
| 10 Menu Navigation. | 23 Power On. |
| 11 Input Selection. | 24 Power Off. |
| 12 Address button. | 25 Stereo Jack. |
| 13 Numeric buttons. | 26 RCU On/Off. |

The projector remote control is a full feature wireless remote control, powered by two (2) standard AA batteries. The battery compartment is on the back side of the remote control.

The remote control is backlit for use in dark environments. It also has an Jack connector for wired connection to the projector. When the wire is connected, the IR beam is switched off.

2.6.4 Remote control, on/off button

Purpose of the remote control on/off button

The Pulse remote control unit has at the front side an on/off switch (reference 1 Image 2-8). Switching off the remote control prevents that unwanted commands are sent due to an accidental key press. Furthermore, switching the RCU off will extend the battery life time of the remote control.

To activate the remote control press the on/off button.

To deactivate the remote control press the on/off button again.

Default when (re)placing batteries, is "ON".

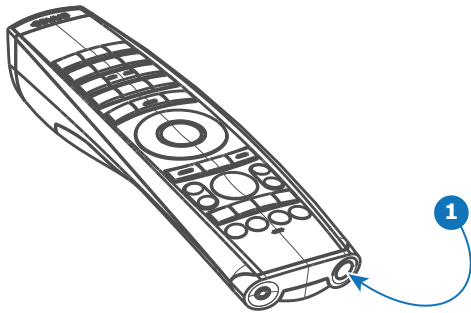

Image 2-8

2.6.5 Function of the RGB filter button

Filtering the color of the projected image

By pressing the RGB filter button on the RCU you can place a color filter on the output of the projector. This feature can be useful during the installation and configuration of a multi-projector or multi-channel setup. By having one projector project a red image and another project a green image, it is easier to spot and adjust the overlap section.

By pressing this button multiple times, you will have different active filters, in the following cycle:

- Red + Green + Blue (default)
- Red only
- Green only
- Blue only
- Red + Green
- Green + Blue
- Red + Blue
- Red + Green + Blue
- etc



After powering up, the colors will always revert back to full RGB.

2.6.6 Enable / Disable Remote Control

About

This function are for disabling the IR sensors for the remote control. Either front or rear, or both.



Image 2-9

- Select the menu path *Home/System Settings/Communication/IR control*
- Select which sensors to be disabled.
- Enter the Apply button to confirm the action



When all sensors are turned off, the projector will not receive any signals from the remote control. To enable the sensors again, use the keypad on the projector.

2.6.7 Wired RC connection

About

The remote control can also be directly wired to the projector from the stereo jack connector on the remote, (See “Functionality overview”, page 27), to the RC connector on the back panel of the projector. (See section “Connector Panel”)

In this mode, the projector will not be affected by signals from other non-wired remote controls.

When using wired remote control, the broadcast address must be set to “Generic ID (0)”. See the menu in “Enable / Disable Remote Control”, page 28.

It is not possible to program the remote control in wired mode. (Directly connected, no sense in programming).

2.7 Projector Address



Projector address

Address installed in the projector to be individually controlled.



Broadcast address

Projector will always execute the command coming from a RCU programmed with that broadcast address.

2.7.1 Controlling the projector

Why a projector address?

As more than one projector can be installed in a room, each projector should be separately addressable with an RCU or computer. Therefore each projector has its own address.

Set up an individual Projector Address

The set up of a projector address can be done via the software.

Projector controlling

When the address is set, the projector can be controlled now:

- with the RCU: only for addresses between 1 and 31.

Broadcast Address

Every projector has a broadcast (common) address '0' or '1'. The default address is '0'.

The choice between '0' and '1' can be selected in the GUI: “System Settings” → “Communication” → “IR Control”.



Placing new batteries in the remote control or plugging the remote to a projector via a cable will automatically reset the address back to its default value '0'.

2.8 Connector panel

General

The source input panel is located at the back of the projector. For source specifications, see table below.

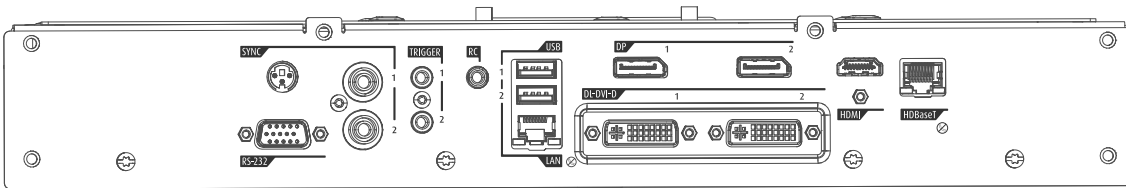
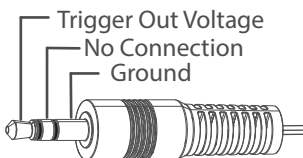

Image 2-10

Name	Pcs	Description	Purpose
RS-232	1	9-pin DB9 connector	For Projector Control. Allows for wired remote control and monitoring of many projector functions used in installation environments
Sync	3	BNC Sync Port IN/OUT; Bidirectional mini-DIN (1x 3D sync Out, and 2x Sync In/Out)	For Projector Control This is mainly used in multiple projector installations with requirement of synchronization between the units
Trigger	2	12VDC - 0,5A (6W) 	For Controlling Peripherals, like motorized screens, curtains etc. Give 12V output when activated. See API manual for activation info. NOTE Disconnect the projector power cable before connecting or removing the trigger cable
RC	1	Jack connector for wired remote	For Projector Control
USB	2	USB 2.0 type A, 4 pin	For Software upgrade
LAN	1	Standard RJ45 connector	For Projector Control
DP	2	Standard display port	For Projector Input
DL-DVI-D	2	Dual DVI-I 1.0 (DVI_D Functionality).	For Projector Input. These connectors can also be used to form one uniform image by feeding half of the image into each connector. HDCP compliant for sources up 165 Mhz
HDMI	1	Standard HDMI 2.0	For Projector Input
HDBaseT	1	Standard RJ45 8P8C Connector	For Projector Input

Lenses

3

Overview

- Approved lenses
- Replace a lens
- Locking the lens position

3.1 Approved lenses

Approved lenses

This table contains the lenses that are within the certification of the projector.

Partnumber	Lens Name	Description (WQXGA)
R9801214	EN11	FLD 1.6 — 2.32:1
R9801218	EN12	FLD 0.74:1
R9801228	EN13	FLD 1.24 . 1.6:1
R9801209	EN14	FLD 2.37 — 3.79:1
R9801225	EN15	FLD 1.16:1
R9801249	EN16	FLD 3.8 — 6.5:1
R9801216	EN41	FLD+ 1.7 - 2.5 : 1
R9801226	EN42	FLD+ 0.8 : 1
R9801230	EN43	FLD+ 1.2 - 1.7 : 1
R9801211	EN44	FLD+ 2.5 - 4.6 : 1
R9801220	EN45	FLD+ Long Focus 0.8 - 1.21 : 1
R9801221	EN46	FLD+ Short Focus 0.8 - 1.21 : 1
R9801295	EN47	FLD+ 0.65 : 1
R9802241	EN61	FLDX 1.7- 2.5: 1
R9802242	EN63	FLDX 1.2 - 1.7 : 1
R9802243	EN66	FLDX 0.8 - 1.21 : 1
R9802244	EN67	FLDX 0.65 : 1
R9802232	EN68	FLD+ 0.28:1
R9801832	UST 90	FLDX 0.38:1



The EN69 lens is not allowed for use in the F40 series projectors, due to RG3 precautions.

3.2 Replace a lens

Lens lever

The L40 lens mount and lens lever is designed to prevent damage to the lens board while providing an easy and stable lens change procedure.

The lens lever, located at the bottom of the lens mount, slides between two positions, far left (default position — unlocked) and far right (locked).



Always activate the projector shutter before attempting to remove or install a lens.

To do this, press the **shutter** button on the keypad, or shutter Close on the remote, to activate the shutter. The keypad button will illuminate red when the shutter is activated.

Press the **shutter** button again, or shutter Open on the remote, to deactivate the shutter and resume normal operation. The keypad button will illuminate white when the shutter is deactivated.



When changing from a lens with motorized Iris, zoom and focus positioning functionality, to a lens without this functionality (e.g. from a EN 63 to a EN42 lens), it is recommended to power down, and pull the AC cord. This is because the memory of the iris position will not be reset, but will show the position in LCD or OSD for the lens that was removed. When rebooting the projector, the memory will be reset.

The reverse scenario will happen when changing from a lens with no motorized positioning support, to a lens with motorized positioning support. The iris position will not be showed with a correct value. The functionality is still present, but the displayed value is not correct.

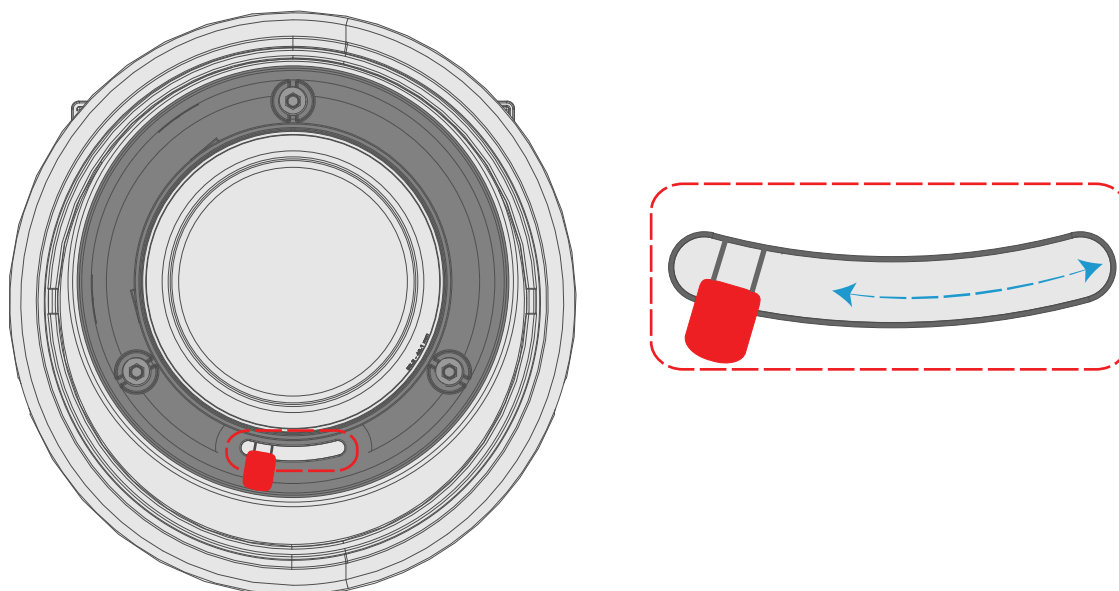

Image 3-1

Install a lens

1. Verify that the projector shutter is activated (shutter is activated when the shutter icon on the projector keypad is red).
2. Verify that the lens release lever is in its default position at the far left of the slide, as illustrated.
3. Remove the protective cap at the lens bayonet end
4. Align the lens so that the red marking on the bayonet is facing upwards.
5. Position the lens bayonet into the projector lens mount and support in place with one hand.
6. Slide the lens lever to the far right.
7. Verify that the lens is firmly in place before removing your hand from the lens.

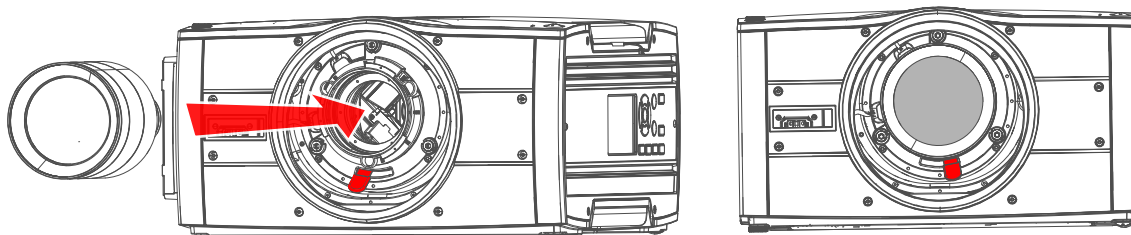

Image 3-2

Remove a lens

1. Support the lens with one hand.

2. Use the other hand to slide the lens release lever to the far left position.
3. Pull the lens straight out of the projector lens mount.
4. Replace with another lens, or install the projector lens cap.

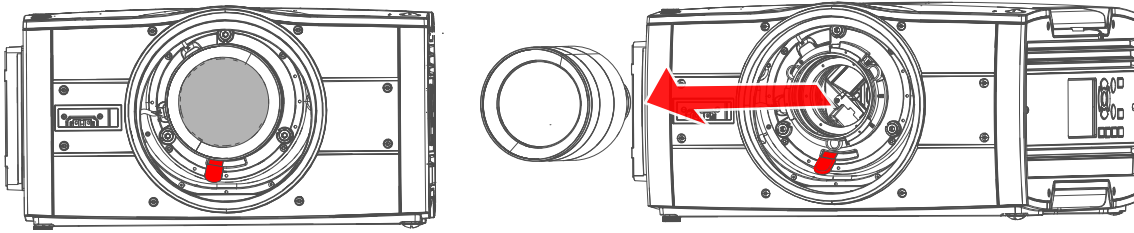

Image 3-3

3.3 Locking the lens position

About

The projector has the feature of mechanically lock the lens position in both horizontal and vertical position.

This is particularly important in moving platform applications in order to avoid that the lens comes out of position during operation. This topic describes the procedure for this operation.



CAUTION:

It is of great importance to disable the Lens Shift function when the mechanically lens lock is performed. If not, the shift mechanism will be possible destructed if lens shift accidentally is performed from the remote control, keypad, and also via API command, when the mechanism is mechanically locked.

Tools needed

- Screwdriver Tx25
- Wrench or Socket wrench 8mm, OR allen key 4mm

Lens lock screw

The lens lock screws has a special design that allows use of two different tools for tightening; 4mm Allen key or 8mm wrench.

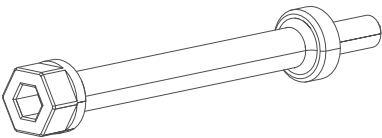

Image 3-4: Lens lock screw



Maximum tightening torque: 2.0 Nm.

Lens lock procedure.

1. Move the lens to the optimal horizontal and vertical position.
2. Disable the lens shift function by entering the menu *Home / System Settings / Service / Lens features*. Select the function to disable by the arrow keys, and disable the function by pressing the OK button.

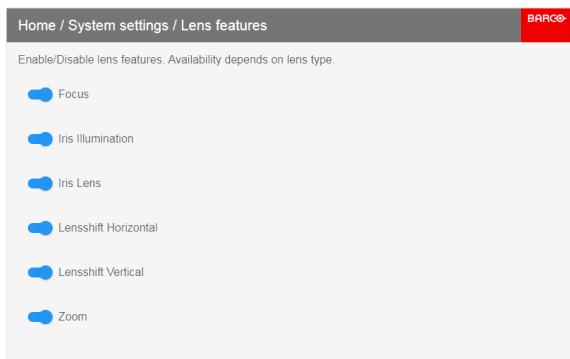

Image 3-5

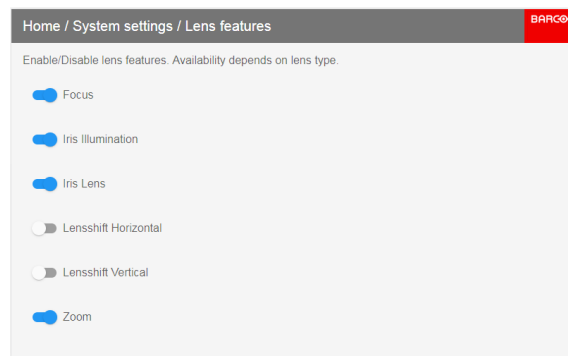

Image 3-6: Toggle by pressing OK button.

3. Release 8 screws in front of the projector indicated in the figure below.

Remove the front cover

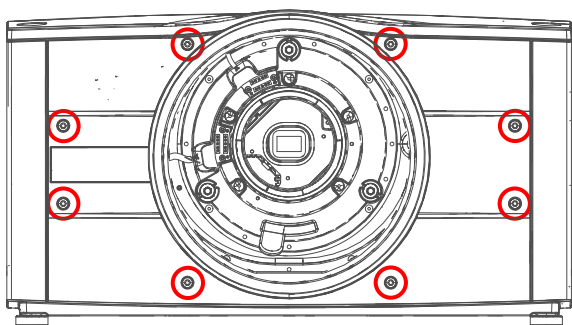

Image 3-7

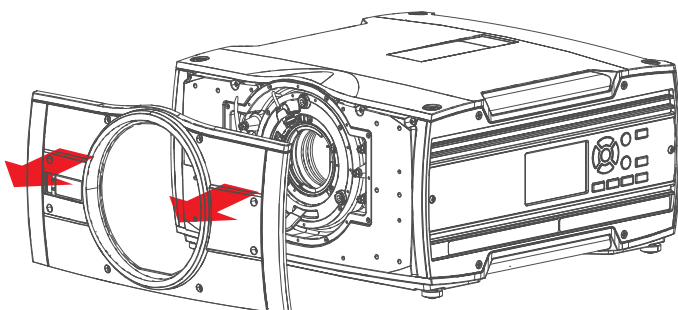

Image 3-8

4. Tighten the screws indicated below.
 Tighten the screws indicated by the **red** circles for locking the **vertical** movement
 Tighten the screws indicated by the **blue** circles for locking the **horizontal** movement

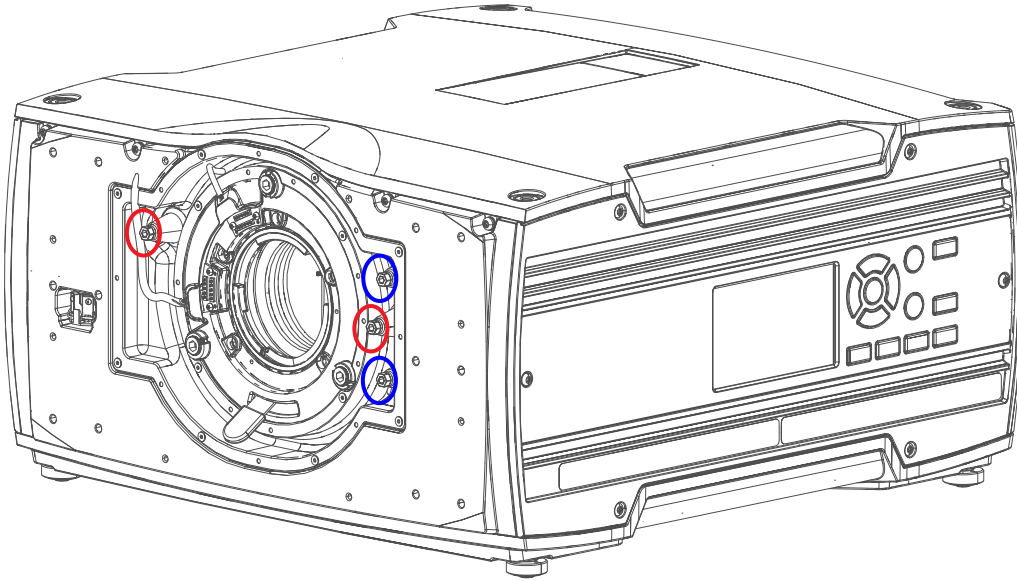

Image 3-9

5. Reassemble the front cover.

Physical installation

4

About

This chapter describes the physical conditions and procedures required when installing the projector. It also describes the outlines and some of the considerations that should be taken in to account when designing and setting up the installation.

Each projector installation is unique, and as such the information in this chapter is only provided as a guideline. Likewise, any images or graphical representations shown here are for illustrative purposes only.

If you require further information and assistance during the installation process, contact a qualified projection technician or your local support office for advice.

CAUTION:



When the projector is installed in a motion platform setup, an additional lens support must be applied, in order to stabilize the lens, and prevent it from separate from the projector and cause damage to equipment and personnel.

This lens support must be adapted to the actual installation. There is no standard solution from Barco available for this purpose.

It is the responsibility of the installer to ensure that the additional lens fixture is approved.

Overview

- Installation process
- Installation conditions
- Initial inspection
- Positioning the projector
- Mounting the projector, general considerations
- Mounting surfaces
- Projector safe attachment points
- Removal of the front cover
- Throw distance
- Scheimpflug (Boresight) adjustment
- Scheimpflug adjustment procedure

4.1 Installation process

Recommended Installation sequence

Item	Procedure
1	Confirm that the installation area meets all technical and environmental requirements
2	Decide where the projector will be mounted
3	Unpack the projector and confirm that all equipment is present and in good working order
4	Mount the projector
5	Install the projector lens
6	Connect the source
7	Power up the projector
8	Set up the image

4.2 Installation conditions

Environmental Conditions



Barco projectors are manufactured according to specific design standards, which also include environmental conditions. Failing to follow the terms and conditions outlined in this chapter can result in loss of product warranty

The table below summarize the physical environments in which the projector may be safely operated or stored.

Environment	Ambient operating temperature	Relative Humidity	Storage condition
0 -1500m	+10 to +40 °C	10 –80% RH	–20 to +60 °C, 10 – 90 % RH
1500 -3000m	+10 to +35 °C	10 –80% RH	–20 to +60 °C, 10 – 90 % RH
Maximum Air Flow	900m ³ /hour	10 –80% RH	Not Applicable



For PRC (People's Republic of China) the certified altitude is specified on the product label.

Mains power requirement

Projector	Power Requirement
Projectors, all in range	100 –240V. 60 –50 Hz.

To protect operating personnel, the National Electrical Manufacturers Association (NEMA) recommends that the instrument panel and cabinet be grounded.

In no event shall this projector be operated without an adequate cabinet ground connection.

The AC supply must be installed by a qualified electrician in conformance to local codes. Hardware, wire sizes and conduit types must comply with local codes.

Ventilation



To ensure that correct airflow is maintained, the projector must only operated when all the covers are in place. The only exception is the front cover, see “Projector safe attachment points”.

The free space necessary between the air intake and exhaust are shown below.

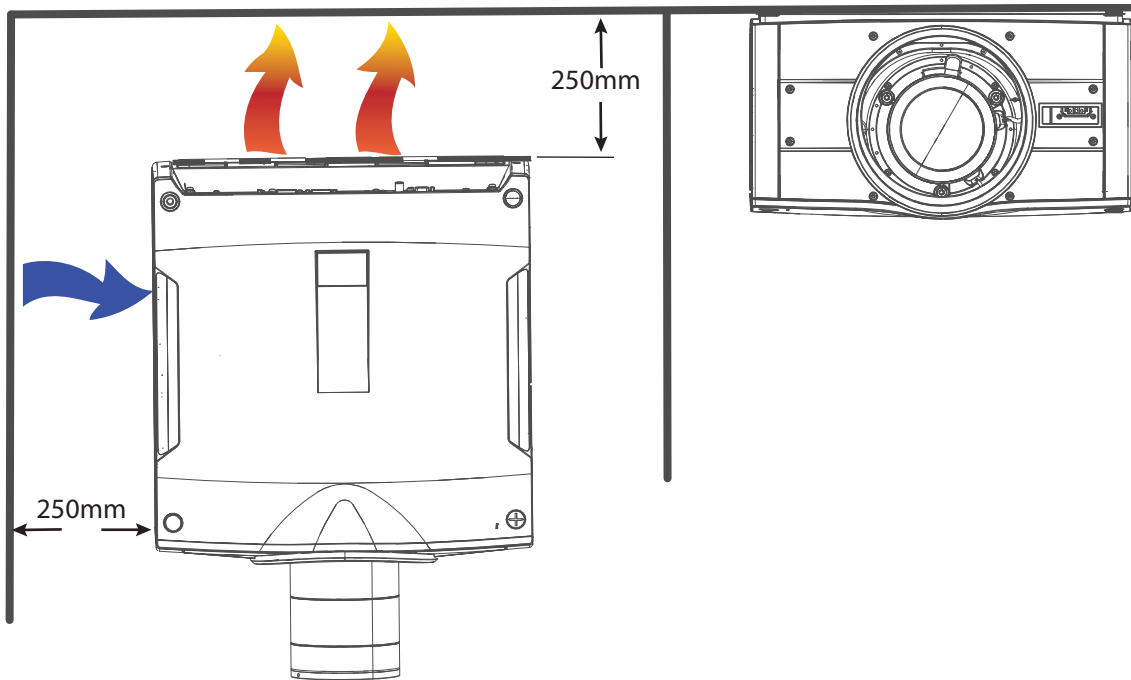

Image 4-1

4.3 Initial inspection

General

Each projector is inspected and rigorously tested at our production facility to ensure that it is free from any mechanical or electrical defects.

Upon receipt of the projector, we recommend that customers inspect the projector for any signs of damage that may have occurred in transit. If damage is found, file a claim with the shipping carrier immediately. Notify the Barco Sales and Service office, or your preferred Barco agent, of the damage as soon as possible.

Box Contents

Your projector box should contain the following:

- Projector unit
- Power cord. (Not all power cords are supplied, see note below).
- Quick start guide
- Safety manual
- Remote Control



If the power cord for your region is not supplied, ensure that the power cord that will be used is according to the regulations for your region. The power cord must be of 3 lead type, where one of the leads is ground. See also the Safety and Environment Information, chapter 1.2 in this document.



The projector lens is delivered in a separate box.

4.4 Positioning the projector



CAUTION: The position and physical securing of the projector must be sufficient to prevent it from accidental or involuntary movement. Proper securing of the projector is the responsibility of the installer and user. The Projector are heavy, and can cause severe damage and injuries if falling.

General guidelines

Proper positioning of the projector lessens the overall picture setup time, and ensures a better image with fewer artifacts.



Focus and sharpness of the image can be adversely affected if the lens axis is not fully perpendicular to the projection surface.



Using extended cable lengths may result in reduced image quality as well as loss of control information such as EDID (Extended Display Information Data).

The following guidelines can help you determine the best physical location for the projector.

- Only install the projector on a sturdy flat surface, or in an approved rigging frame.
- Do not install the projector in a thoroughfare or another area where it is at risk of being pushed or jostled.
- Allow sufficient free space around the projector for ventilation and exhaust, as described in section 4.2
- Use the throw ratio of the installed lens as a guideline for the projector's physical distance from the screen.
- Wherever possible, the projector lens surface should be positioned so that it is perfectly perpendicular to the center of the screen.
Use the projector offset (lens shift), rather than physical angling, to correct any off-center positioning.
- Minimize the source cable length as much as possible.
DP, HDMI and DVI are short-haul interfaces using pre-assembled cables with limited cable lengths.
- Limit the use of power cable extensions wherever possible. Where physical limitations necessitate their use, make sure that the extension cord has adequate surge protection and meets all electrical requirements of the connection.
- Keep the projector away from equipment that emits electromagnetic energy for example, motors, transformers and elevators.

4.5 Mounting the projector, general considerations

Mounting safety

When mounting a projector in a rig, always use an interface plate (between the projector and the mount) that has provision for a safety wire or another safety mechanism, to ensure that the projector does not fall down should the interface plate come loose from the mount.

Always screw the interface plate securely to the projector body while the projector is on the ground (i.e. cannot fall down). Then attach proper safety wire between the interface plate and the rig before mounting the projector in the rig

Using 3rd party mounting equipment

The projector has features for mounting into various system environments using 3rd party mounts See "Projector safe attachment points"..

The feet can be removed and threads can be used for additional mounting points. See table below for dimensions.



Where possible, the projector lens must be positioned exactly perpendicular to the center of the screen. Use the projector offset (lens shift), rather than physical angling, to correct any off-center positioning.



CAUTION: The position and physical securing of the projector must be sufficient to prevent it from accidental or involuntary movement. Proper securing of the projector is the responsibility of the installer and user.



CAUTION: Always use a Rigging Frame when the projector shall be mounted in other ways than on the feet, on a flat surface.

4.6 Mounting surfaces

Mounting on a flat surface

1. Position the projector at the desired location.
2. Power up the projector.
3. Go to *Main Menu / Test Patterns* and select an internal hatch pattern to display on the screen.

Mounting to a ceiling

1. Install the projector in to an approved rigging frame.
2. Install the rigging frame to the desired location.
3. Power up the projector.
4. Go to *Main Menu / Installation / Orientation* and select the correct orientation for your setup.
5. Go to *Main Menu / Test Patterns* and select an internal hatch pattern to display on the screen.
6. Adjust the position (height and angle) of the rigging frame until the projected hatch pattern is a level and perfect rectangle.



If applied in a motion rig, care must be taken to stay within the environmental specifications for vibration and shock.

Contact Barco for more information regarding these specifications.

It may also be necessary to use additional, custom made brackets to stabilize the projection lens to make sure that the projected image remains in position and properly focused.

4.7 Projector safe attachment points

Anchor points bottom plate

Due to use of a Rigging Frame or other equipment, the projector has some defines anchor points that shall be used. See the illustration below.

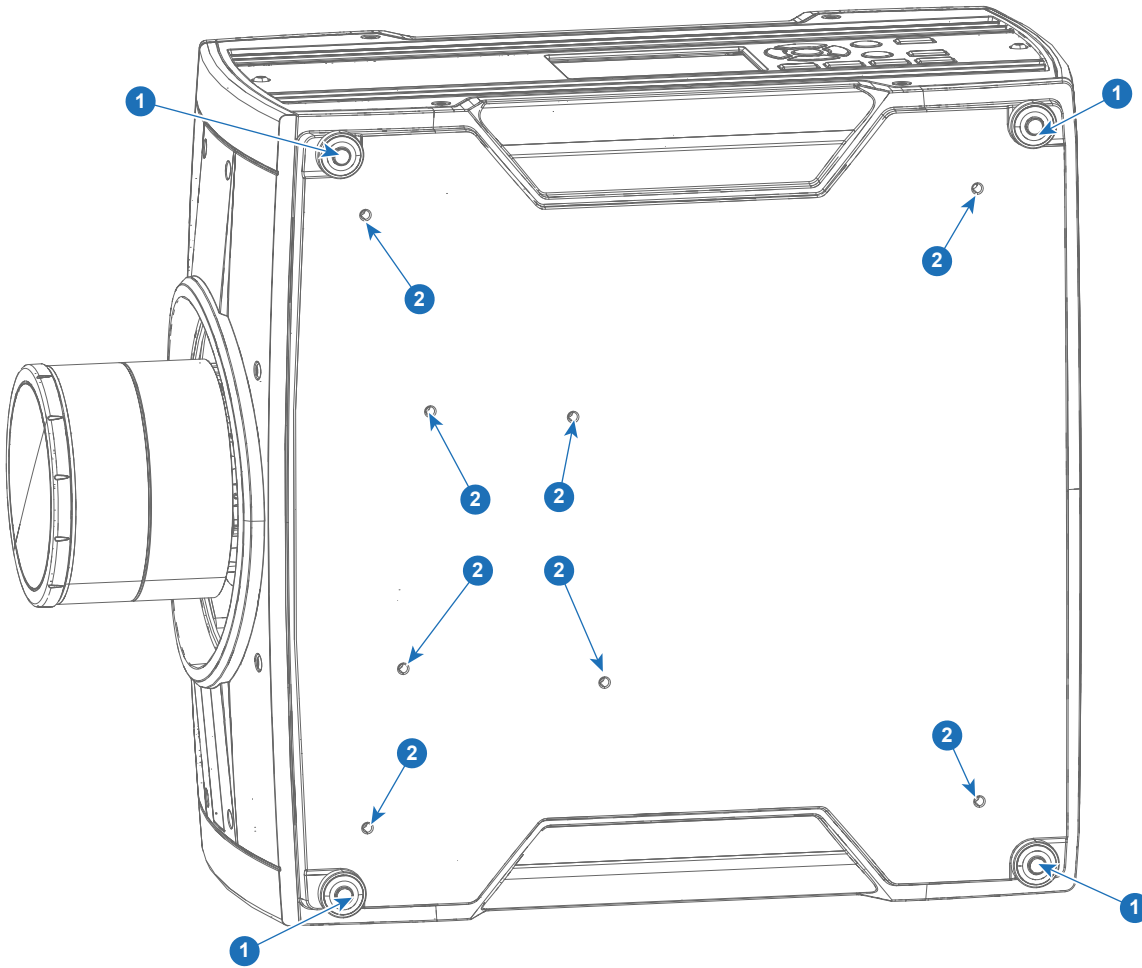

Image 4-2: Bottom anchorpoints

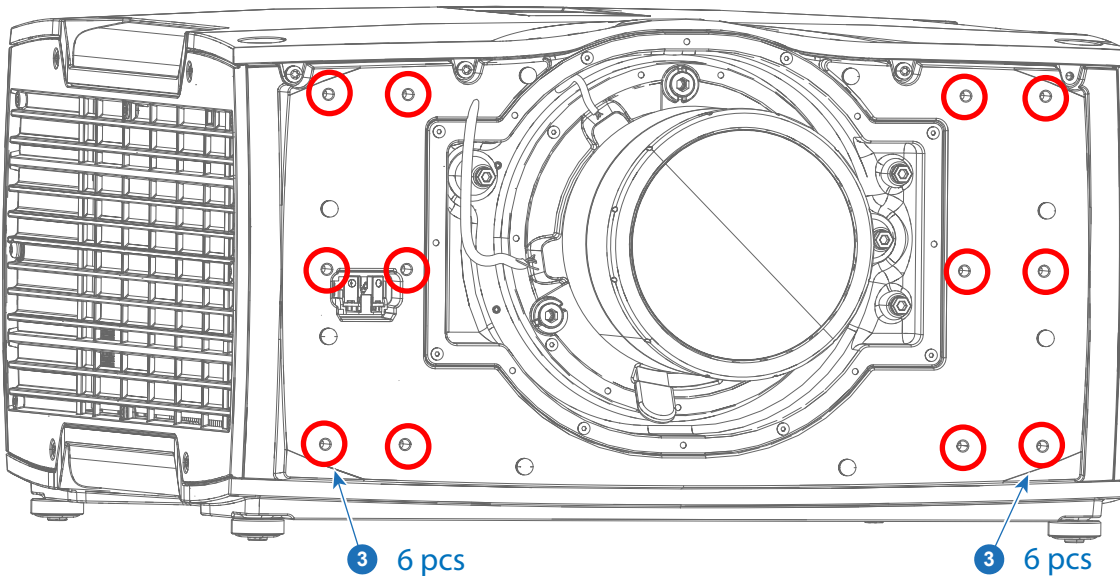

Image 4-3: Front anchorpoints

Item	Thread Dimension	Max Hole Depth	Application
1	M8	15mm	Anchorpoint / Ceiling / Rig Mount
2	M6	10mm	Anchorpoint / Ceiling / Rig Mount
3	M6	10mm	Lens and Blend support (Can also be used a anchorpoints)



WARNING: A minimum of 4 anchor points must be used to secure the projector properly. It is strongly recommended to use fixation points with as long mutually spacing as possible, in order to increase the mechanical stability of the installation.



WARNING: Max tensile load for each anchor point is 43,75 kg. This must be a major consideration when designing the brackets for fixation of the projector.

Anchor points front

There is also 12 anchor points in the front. They will be visible when the plastic front cover is removed. See “Removal of the front cover”, page 43 below, regarding how to remove the front cover.

These anchor points are mainly intended for lens support and other “extras”, but can also be used as anchorpoints.



WARNING: When installing the projector in a motion platform application, the anchor points in front (Item 3 in the illustration and table) must NOT be used. Use the anchor points in the bottom plate for this purpose.

4.8 Removal of the front cover

Required tools

Screwdriver TX20

Procedure

Remove the lens.

Remove the 8 screws, and pull the cover out.

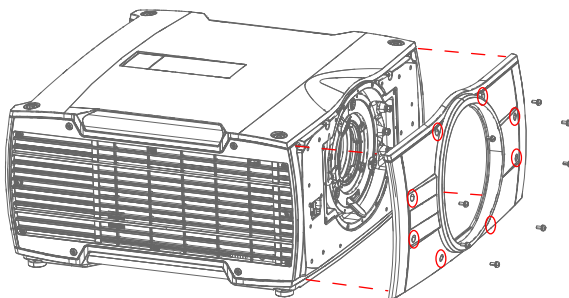

Image 4-4

4.9 Throw distance

Calculate the installation throw distance

Throw is the distance (D) measured from your projector lens to the screen. To calculate the throw distance for an installation, you will need two pieces of data: the selected lens throw ratio (L) and the horizontal width (W)

of the screen. For example, if the screen width (W) is 2.4 meters and the projector lens has a throw ratio (L) of 0.99:1, then the throw distance (D) will be 2.38 meters.

Calculation: $2.4 \times 0.99 = 2.38$

The following graphs illustrate the image size (W) and projection distance (D) for each of the projector lenses.



Tolerances are typically +/- 5% due to optical (lens) variation.

Throw distance, FLD WUXGA

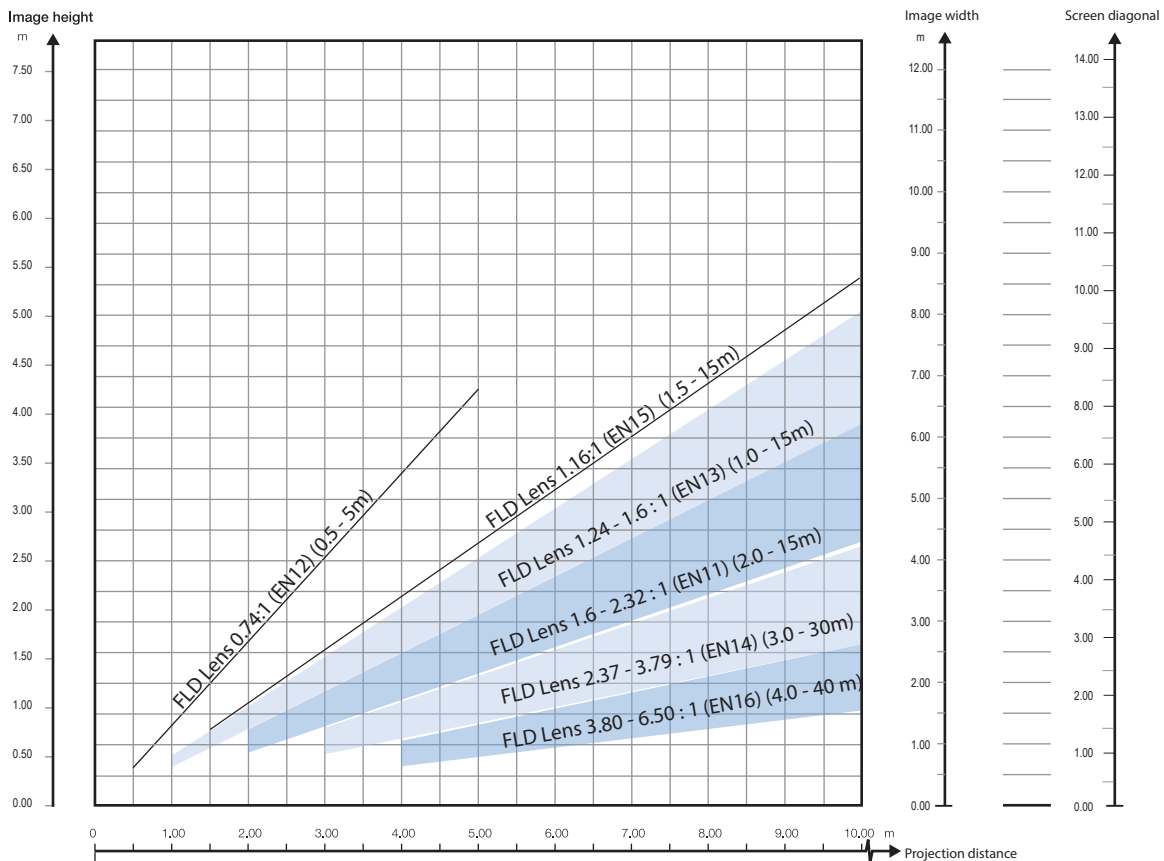

Image 4-5

Throw distance, FLD+ / FLDX WQXGA / 4K UHD

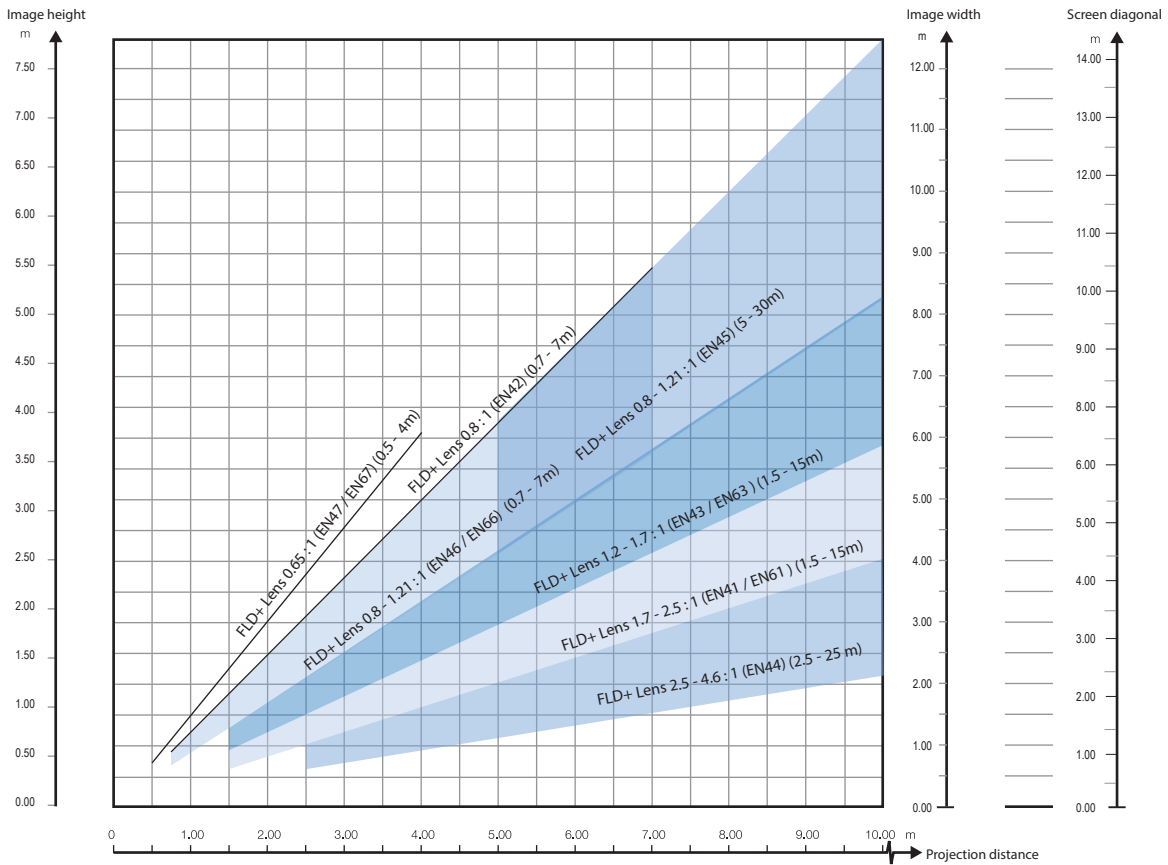

Image 4-6

Throw distance, FLD+ / FLDX WUXGA

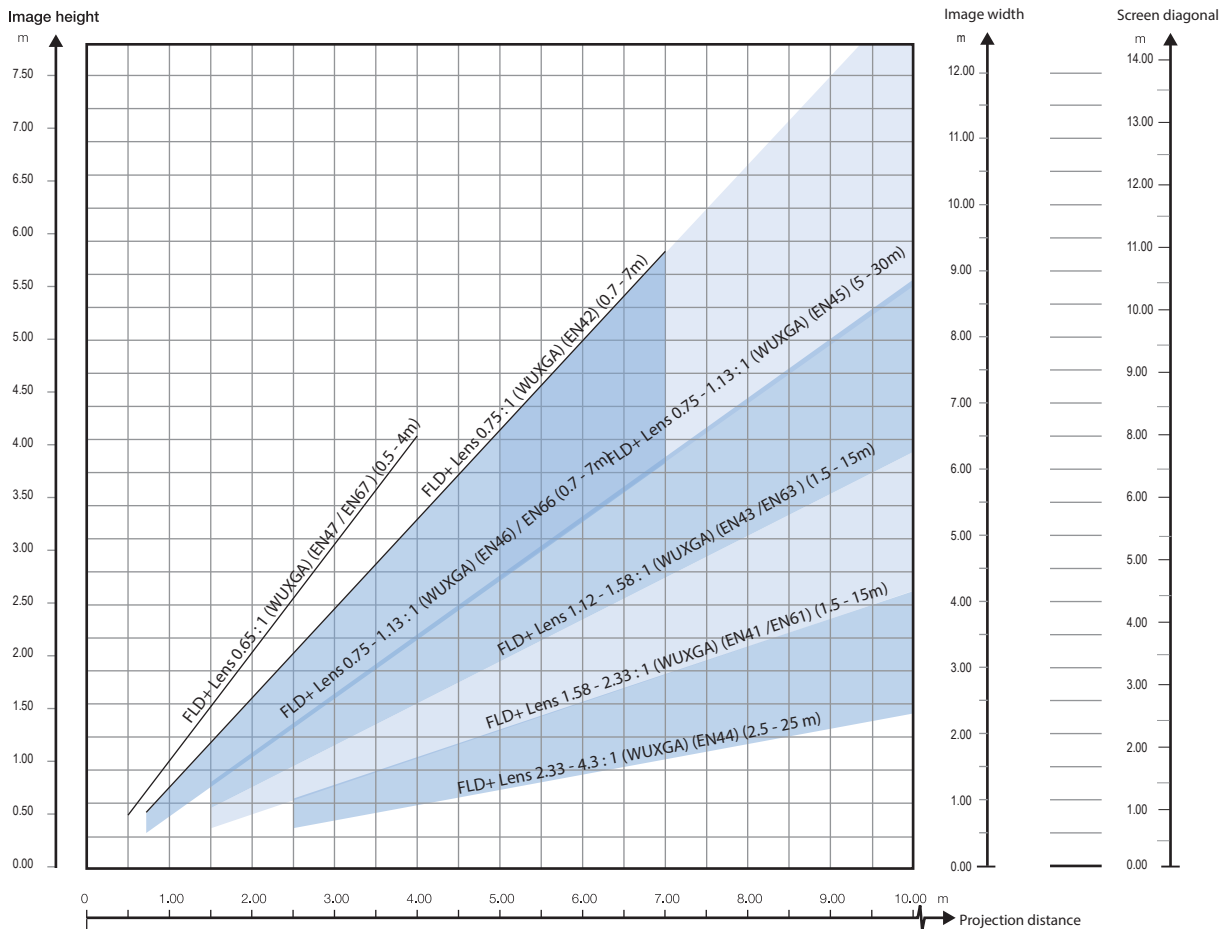

Image 4-7

4.10 Scheimpflug (Boresight) adjustment

What is Scheimpflug?

The lens holder has to be adjusted so that the “sharp focus plane” of the projected image falls together with the plane of the screen (Fp1→Fp2). This is achieved by changing the distance between the DMD plane and the lens plane (Lp1→Lp2). The closer the lens plane comes to the DMD plane the further the sharp focus plane will be. It can occur that you won't be able to get a complete focused image on the screen due to a tilt (or swing) of the lens plane with respect to the DMD plane. This is also known as Scheimpflug's law. To solve this the lens plane must be placed parallel with the DMD plane. This can be achieved by turning the lens holder to remove the tilt (or swing) between lens plane and DMD plane (Lp3→Lp4).

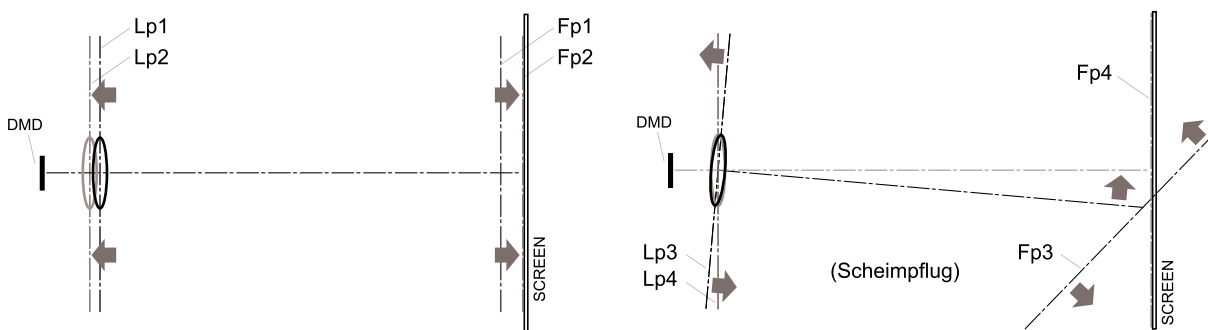

Image 4-8: Scheimpflug principle

Scheimpflug principle

The "plane of sharp focus" can be changed so that any plane can be brought into sharp focus. When the DMD plane and lens plane are parallel, the plane of sharp focus will also be parallel to these two planes. If, however, the lens plane is tilted with respect to the DMD plane, the plane of sharp focus will also be tilted according to geometrical and optical properties. The DMD plane, the principal lens plane and the sharp focus plane will intersect in a line below the projector for downward lens tilt.

Scheimpflug adjustment points

Scheimpflug adjustment points are located on the lens mount. The F70 has three (3) set screws and three (3) adjustment screws.

When to apply Scheimpflug?

Scheimpflug correction procedures may only be carried out by suitably trained and experienced technicians.

A Scheimpflug correction should only be applied when the overall focus of the projected image is not equally sharp (for example, if the projector is **NOT in parallel** with the screen or as a result of a previously misaligned Scheimpflug). Be aware that the consequence of applying Scheimpflug correction upon a screen not in parallel with the projector is that the projected image differs from the rectangle shaped image. In other words "distortion" of the projected image occurs. **Masking** will be required to solve the distortion.

The disadvantage of Masking is loss of content. Therefore it is **strongly recommended** to place the projector **in parallel** with the projection screen and use the *SHIFT* functionality of the Lens Holder to match the projected image with the projection screen. If the SHIFT range is not sufficient then the projector can be tilted and Scheimpflug can be applied.

4.11 Scheimpflug adjustment procedure



CAUTION: A Scheimpflug adjustment should only be carried out by properly qualified and experienced projection specialists. A poor Scheimpflug adjustment may result in an extremely degraded image and will require factory—servicing to the projector.

Required tools

- Allen key, hex size 4
- Allen key, hex size 6

Preparation

1. Prepare the test area. Barco recommends a projector-screen distance of 2 metres be used for all Scheimpflug adjustments.

Verify that the throw ratio of the installed lens matches the requirements of the installation area (projection distance and screen size).

2. Check that the lens is correctly installed, and lens shift is in centre position.
3. If the installed lens has Iris control, open the Iris all the way up.
4. Open the focus ring all the way up.
5. Go to Main Menu / Test Patterns / Full Screen and select to display the Focus test pattern.
6. Zoom the lens to its widest opening (maximum image size on the screen).

Apply a Scheimpflug correction

1. Loosen the three set screws (reference 1b, 2b, 3b). Use a size 6 hex key to do this.

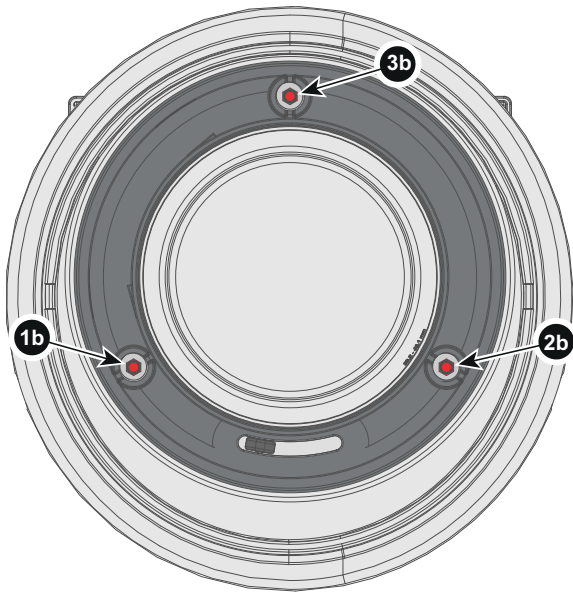



Image 4-9

2. Adjust the left side Scheimpflug adjustment screw (reference 1) until the test image in the top right side of the screen is in focus. Use a size 4 hex key to do this.

 **Note:** This process may cause the other areas of the image to slide out of focus. This is totally normal.

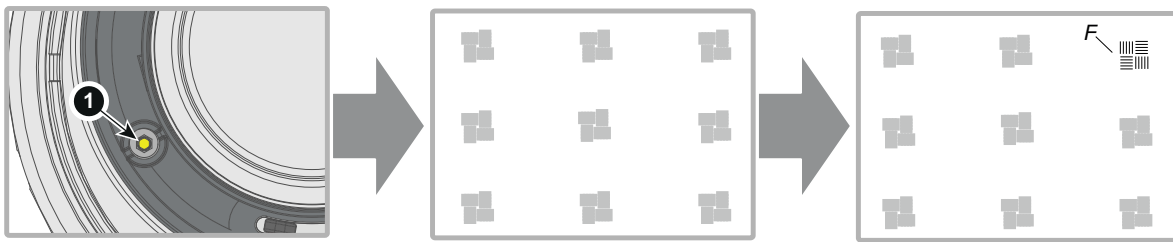



Image 4-10

3. Adjust the right side Scheimpflug adjustment screw (reference 2) until the test image in the top left side of the screen is in focus. Use a size 4 hex key to do this.

 **Note:** This process may cause the other areas of the image to slide out of focus. This is totally normal.

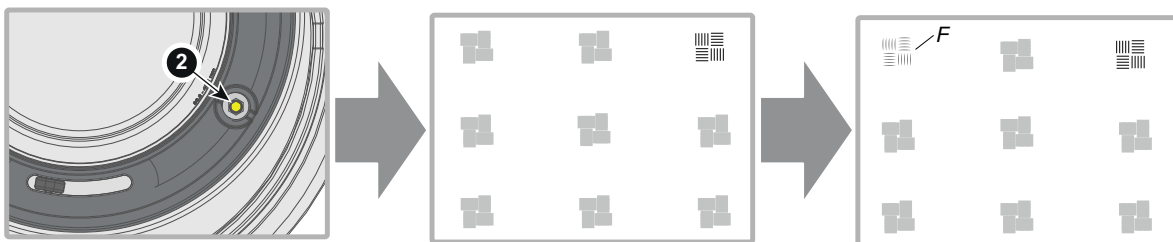



Image 4-11

4. Adjust the top Scheimpflug adjustment screw (reference 3) until the test image in the bottom half of the screen is in focus. Use a size 4 hex key to do this.

 **Note:** This process may cause the other areas of the image to slide out of focus. This is totally normal.

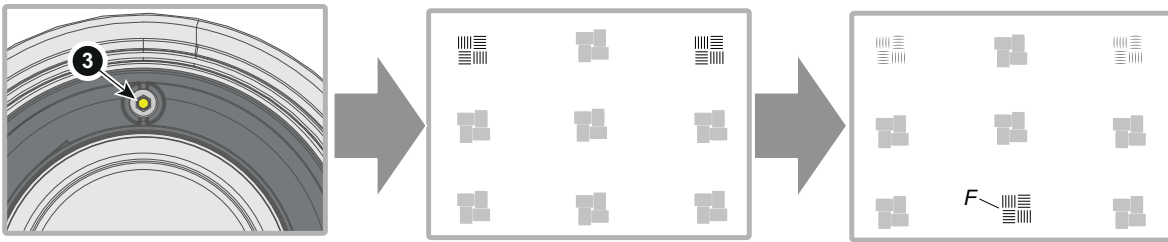

Image 4-12

5. Continue adjusting the screws one at a time until the test image is uniformly sharp across all areas of the display.
6. Test the focus by zooming out (minimum image size on screen) and then zooming in again. Verify the image is still sharp. If there are any deviations to sharpness, repeat steps 2 to 6 until the image is correct.
7. Tighten the three set screws in the following order: left (1b), right (2b) and then top (3b). Use a size 6 hex key to do this.

Getting the projector started

5

Overview

- Projector source and control connections
- Power up the projector
- Power down the projector
- Power mode transitions
- Power modes
- Customize projector settings
- User interface

5.1 Projector source and control connections

5.1.1 Input source connections



The source switching time is variable and could take few seconds..

Source signal connectivity

The connector panel at the back of the projector is used for all source connections.

Source signal connectivity on the projector is:

- 2x Dual Link DVI-I (DVI-D functionality)
- 2x DisplayPort 1.2
- 1x HDMI 2.0
- 1x HDBaseT

5.1.2 Connector Specifications

Overview

- DVI-I
- Display Port 1.2
- HDMI 2.0
- HDBase T

5.1.2.1 DVI-I

Specifications

Parameter	Value
Connector	DVI-I female digital RGB
Signal characteristics	DVI 1.0, Digital, TMDS
Max. cable length	25 m (24 AWG)
Max. pixel rate	330 MHz (dual link), 165 Mhz (single link)
Scan format	Progressive
Max. input data resolution	1920x1200 60Hz (Single link), 2560x1600 60Hz (Dual Link), 1920x1200 120 Hz (Dual Link), 1920x2400 @60Hz
Bit depth	8 bit
EDID	Supported
HDCP	Supported

5.1.2.2 Display Port 1.2

Specifications

Parameter	Value
Connector	Standard Display port
Signal characteristics	DP 1.2
Functionality	Mandatory

Parameter	Value
Max. cable length	2 m (24 AWG) - RBR; 2 m (24 AWG) – HBR1, HBR2
Supported Link Rate	RBR, HBR1, HBR2
Scan format	Progressive
Max. input data resolution	2560x1600@120Hz WQXGA / 3840x2400 @60Hz (4K) Max
Bit depth	8, 10, 12 bit
EDID	Supported
HDCP	Supported

5.1.2.3 HDMI 2.0

Specifications



Regarding HDMI 2.0: The decryption protocol HDCP 2.2 are enabled and valid in this unit.

Parameter	Value
Connector	Standard HDMI
Signal characteristics	Digital, TMDS
Max. cable length	2 m (24 AWG)
Max. pixel rate	594MHz
Max. input data resolution	3840x2160 @60Hz
Bit depth	8, 10, 12 bits
EDID	Supported
HDCP	Supported
Ethernet	No
Audio return	No
HDCP	Supported

5.1.2.4 HDBase T

Specifications

Parameter	Value
Reference specification	HDBaseT 1.0 Specification, June 2010
Connector	Standard RJ-45, 8P8C
Signal characteristics	HDBaseT
Max. cable length (1080p/48b/60Hz)	100 m (Cat5e/6), Pixel Clock <=225MHz, Video Datarate <=5.3Gbps 70 m (Cat5e/6), Pixel Clock >225MHz, Video Datarate >5.3Gbps 100 m (Cat6a/7), Pixel Clock >225MHz, Video Datarate >5.3Gbps
Max TMDS Clock Frequency	270 MHz

Parameter	Value
Max video resolution supported	1920x1200 @60Hz (WUXGA 60Hz)
HDCP Pass-Through	Yes, from Source to Projector
IR Extension	Not Supported
RS-232 Extension	Not Supported
10/100Mbps Ethernet Pass-Through	Not Supported
Fallback to 100BaseTx, IEEE 802.3u	Not Supported
USB Over Centre Tap	Not Supported
Power Over Ethernet	Not Supported
Audio	Not Supported
LEDs - HD Base Status	Operation: Green, Left Link/Mode: Yellow, Right

5.1.3 Control Interfaces

About

The following control interfaces are available on the projector:

- 1x RS-232 (for projector control)
- 1x LAN/Ethernet (for projector control)
- 2x USB-A ports

Overview

- RS-232
- LAN/Ethernet
- USB-A port

5.1.3.1 RS-232

Specifications

Parameter	Value
RS-232 connector	1 female DB9 connector (RS232-in) for projector control and debug

5.1.3.2 LAN/Ethernet

Specifications

Parameter	Value
Ethernet connector	1 RJ45 Connector for projector control (not content)
Protocols	DHCP, TCP/IP, UDP/P
Speed	10/100 Mbit/1000Mbit

5.1.3.3 USB-A port

Specifications

Parameter	Value
USB connector	Type A

Function	Firmware upgrade using USB sticks
Power	Power 5V, max 1,5A (out)
Standard	USB 2.0

5.2 Power up the projector



CAUTION: Sources should always be connected before the projector is powered up



CAUTION: Ensure that the main power cord complies with the national regulations where the equipment is used.

Do not use unauthorized replacements.

Do not use power cords which are damaged.

Power up the projector using the keypad or remote

1. Connect the line cord to the projector.
2. Plug the 3–pronged cord into a grounded AC outlet.
The projector will begin warming up, and the backlight of the Standby /power button are flashing white.
3. When the backlight on the standby button are constant white, the projector are in standby mode, ready to be switched on.
4. Press the standby button on the keypad or the power button on the remote to bring the projector up to on mode.
The power button backlight on the keypad will flash blue while the projector is warming up.
5. When the power button backlight is steady blue, the projector is ready for use.

5.3 Power down the projector

Power down using the keypad or remote

1. Depress and hold the power button on the keypad or remote for four (4) seconds.
The Projector is now in cooling down phase.
2. Wait 2 minutes before disconnecting the power cord. (If disconnecting is required).



WARNING:

There is a risk of reducing the expected lifetime of the projectors DMD device if the power cord is removed too early, due to the device's shutdown sequence.

5.4 Power mode transitions

5.4.1 General

Transition Diagram

This diagram shows all modes available on the projector (unplug, ON, READY, ECO), and the actions necessary to change mode.

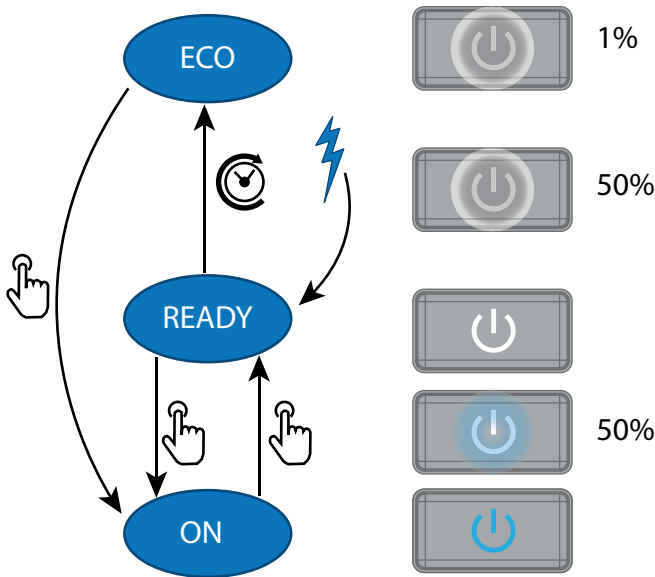





Image 5-1

-  Projector mains powered
-  Auto transition after x minutes if ECO mode enables
-  Press power On/Off button, remote On/Off button

5.4.2 Power on projector



If not already connected, connect the female side of the power cord with the power input socket of the projector. For more details see section dedicated to the power cord installation.

Description

Plug the 3-prong plug of power cord into a grounded AC outlet. The projector will go to **READY** mode. During this stage the system boots and performs the internal check of the boards. The *Power On/Off button* will BLINKING WHITE until **READY** mode is achieved. Once in **READY** mode, the *Power On/Off button* will be lit WHITE.

5.4.3 Going from READY to ON

Description

Press the *Power On/Off button* on the projector, or the *Power On* button on the remote control. The projector will power **ON**. The *Power On/Off button* will BLINK BLUE during the transition from **READY** to **ON**. Once the projector is on, the *Power On/Off button* will be lit BLUE.

5.4.4 Going from ON to READY

Description

Press and hold the *Power on/off button* on the projector for 4 seconds, or press the *Power Off* button on the remote control. The projector will power down through a cool down phase. The *Power on/off button* will BLINK WHITE during the transition from **ON** to **READY**. Once the projector is in **READY**, the *Power on/off button* will be lit WHITE.

5.4.5 Going from READY to ECO standby

Description

If ECO Standby mode is enabled in the service menu (refer to the section "GUI - system settings/Standby ECO", in User Guide) the projector will automatically go to **ECO** standby mode after a time-out (default 15 minutes). All electronics (including fans, pumps,...) go down except for a very small wake up controller. The *Power on/off* button will FLASH WHITE every second.

5.4.6 Going from ECO to ON

Description

Press the *Power on/off* button on the projector, or the *Power On* button on the remote control. The projector goes from **ECO** directly to **ON**. The projector will go through the same booting phase as on power plugging, then do the transition from **READY** to **ON**. Of course startup-time will be longer then from **READY** to **ON**.

5.4.7 Wake On LAN (WOL)

About

The projector has WOL functionality, that can be used for the projector to go from ECO mode to READY mode. Use a json command for transition from READY to ON.

The WOL is performed by sending a Magic Packet followed by the projectors MAC address. The MAC address is found in the menu *Home / System settings / Communication / LAN*. The MAC address is similar to the HW address that is shown in this menu path.



The LAN cable must be connected when the projector enter the ECO mode, in order to obtain the Wake on LAN function.

5.5 Power modes

General

The table below details the F70 power modes.

Mode	Description
Normal	Projector is booted up and the light source is on
Ready	Projector is booted up but the light source is off
ECO Standby	Light source is switched off and projector electronics are powered down

5.6 Customize projector settings

About

The projector display, behavior and user interface can be adjusted to meet individual requirements.

Options include: *Home/System Settings/Themes*

- Adjust the OSD menu color

5.7 User interface

Overview

- On Screen Display (OSD)

5.7.1 On Screen Display (OSD)

About

The projector on screen display (OSD) is the primary user interface (UI). From here, you can review and adjust all projector and display settings.

The OSD interface uses tabs to display the main menu. Topics are then further sorted and displayed by function: main (topic) — sub (function) — sub (function).

There are six main menu tabs: Source, Image, Installation, System settings, Test pattern and Status.

The OSD can be disabled by pressing the OSD on/off button.



In order to show the OSD, the OSD On/Off button must be disabled. (White backlight on the button). When the button have blue illumination, the OSD will not appear, and the display information are only visible on the LCD Display. Only Critical warnings will be displayed.

User access levels

The projector's software platform uses access levels to define what each user can do.

There are two user access levels: Standard User and Power User. In addition, there is a Service user access for certified Service personnel.

A standard user has access to all projector functionality and OSD menu items. A power user has, in addition to access to all projector functionality and OSD menu items, access to a number of advanced functions. Access to power user features is password-protected. Contact your projector supplier for more information.

Navigation

You can navigate the OSD using the local keypad or the remote control.

Press the MENU button to display the OSD. (The OSD must be enabled, press OSD button to enable.)

Use the arrow keys to navigate left, right, up and down.

Press the OK button to select a menu topic and get more options.

Use the numeral keys to enter values, or use the arrow keys to move the barscale up or down.

Press MENU again to exit the menu system.

Press the OSD button to deactivate the OSD on the screen. Only critical warnings will be displayed.



Some menu options are reserved for Power or Service Users; these will be grayed out and not available for selection when in standard user mode. To access these features, enter your Power or Service Code in the Service Menu or contact your support representative for more information.

Define values

Menu settings are displayed using checkboxes, barscale sliders, and drop-down lists.

To set a value:

- Press OK to select or deselect a checkbox (turn a function ON or OFF).
- Use the arrow keys to move the barscale slider up or down on the value line. For a barscale 0-9, each step will equal 10% of the total value.
- To enter the value as a direct number, press ENTER, input the digit(s), and then Press ENTER again to execute and exit cursor mode e.g. ENTER 79 ENTER.

Changes to values are implemented dynamically.

Menu memory

The OSD menu remembers the last selected sub-item as long as the projector is running. The menu memory is reset when restarting the projector from standby.

Source menu

6

Overview

- Connector selection
- Connector settings
- Using dual inputs

About the Source menu

This menu is used to select, review and configure sources into the projector. Enables either via the source menu, or the shortcut key.

By navigate through the Home/Source menu, it will be visible also on the OSD.

By using the shortcut key, the menu occurs only on the LCD display.

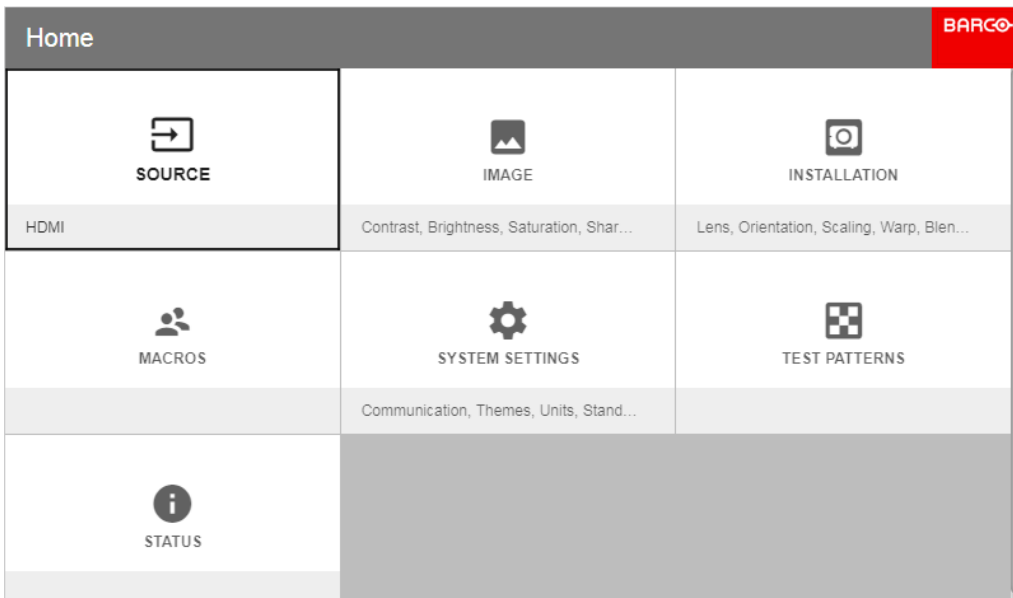

Image 6-1

6.1 Connector selection

About

Home/Source

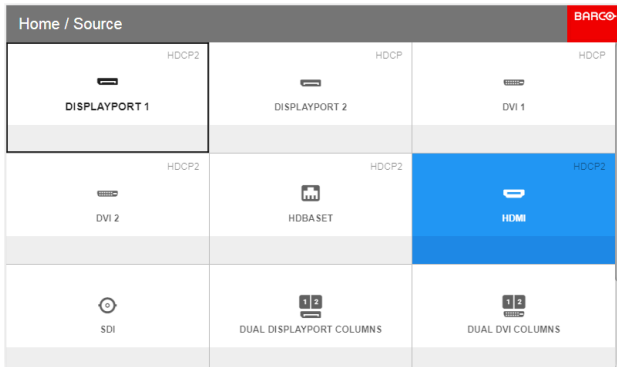

Image 6-2

Click on the relevant input connector icon to swap or activate the source.

The icon for the active source is highlighted.

The list of displayed sources can be adjusted to include other connectors.

The default selection of connectors displayed is:

- Display Port 1
- Display Port 2
- Dual Displayport Columns
- Dual Displayport Sequential
- DVI 1
- DVI 2
- Dual DVI Columns
- Dual DVI Sequential
- HDBaseT
- HDMI

6.2 Connector settings

About connector settings

The Connector Settings menu allows you to change settings for each input connector of the projector.

By default all options for every connector are set to automatic, together with the native Extended Display Identification Data (EDID).

When entering the menu for each input connector, you can change the following:

- Color Space
- Signal Range
- EDID

How to configure a connector

1. Press **Menu** to activate the menus and select **Source**.

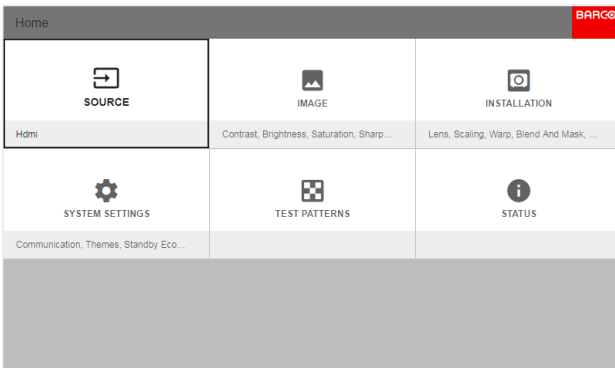

Image 6-3: Select source

2. Press **OK**.

The *Home / Source* menu is displayed with the actual available sources filled out.

3. Scroll down to the bottom of the list of available sources and select *Connector Settings*.

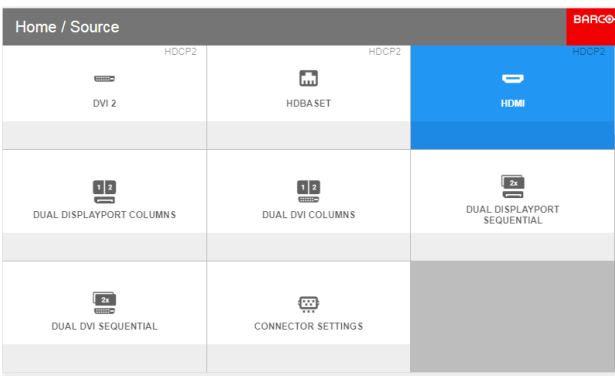

Image 6-4: Source menu — Connector settings

The available input connectors are displayed.

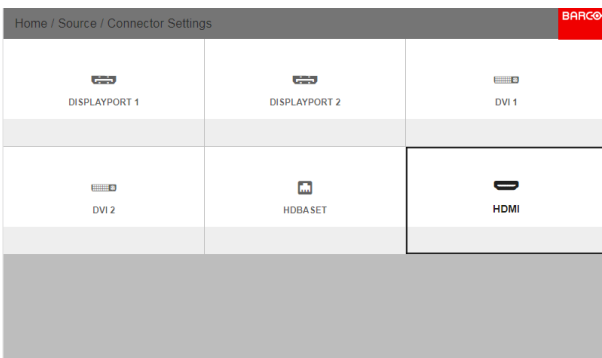

Image 6-5

4. Select the desired connector.

The **Connector Settings** menu for this connector will be displayed.

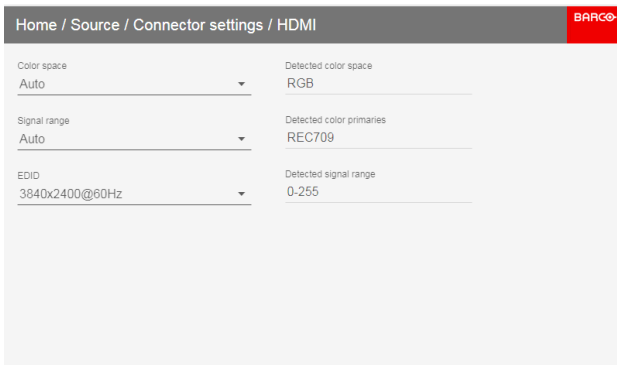



Image 6-6: Example of connector settings of an HDMI Connector.

5. You can change the following:

- To force a limit on the color space, select one of the available *color spaces*.
- To force a limit on the used signal range, select one of the available *signal ranges*.
- To set a video timing other than the one native for the connector, select one of the options under *EDID*.

 **Note:** You cannot change the EDID for SDI connectors.

6.3 Using dual inputs

Dual Input.

For extended flexibility to connect high resolution sources with a pixel clock over 330 MHz, the projector is supporting a dual input mode. In this mode, the left and the right half of the image can be connected to the DVI-1 and DVI-2 respectively, or DP1 and DP2.

To enable this mode, select the source that fits in the menu *Home/Source*

Dual input modes

There are four ways to connect dual input.

- Dual Displayport Columns
- Dual Displayport Sequential
- Dual DVI Columns
- Dual DVI Sequential



For Images to be displayed in this mode, the resolution must be the same on both channels

Signal source setup.

When using dual inputs, it is important that the signal sources are set up correctly, with the correct resolution. Please refer to the manual for the source itself (PC, Graphic driver card..) in order to obtain a correct setup. If the setup is wrong, no picture will be visible in dual mode.

The resolution for each dual column channel can be up to 1920x2400 pixels.

The resolution for each dual sequential channel can be up to 3840x2400 pixels. (4K)



Change the EDID for each channel to the correct value. See chapter "Connector Settings" for EDID setup.

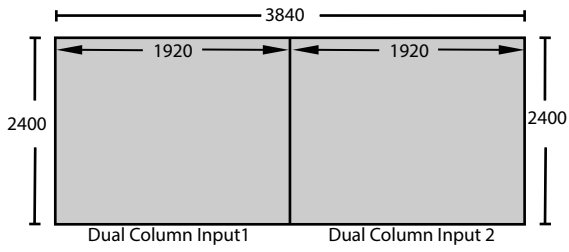

Image 6-7: Dual Column Setup

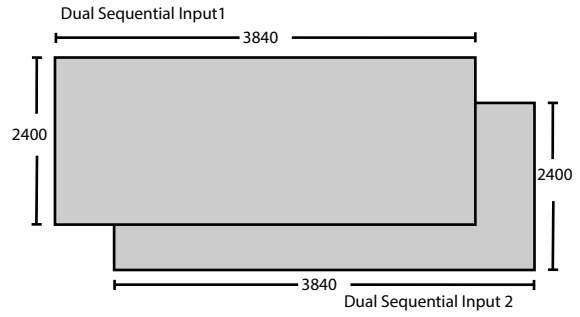

Image 6-8: Dual sequential setup.

7

Image menu

Overview

- Contrast
- Brightness
- Saturation
- Sharpness
- Gamma adjustment
- Gamma Types
- Digital Zoom Shift
- Advanced image adjustments

About Image adjustment menus

There are different menu pictures showing up for the LCD display and the OSD. For the LCD display, the menu is shown below. The OSD menu is shown in the different topics below, and is visible in the lower left corner of the screen. The operation of the menus can be done with both the remote control or the arrows on the keypad. It is also possible to switch between the different adjustments by using the up and down arrows, instead of exit one menu and then enter the next one.

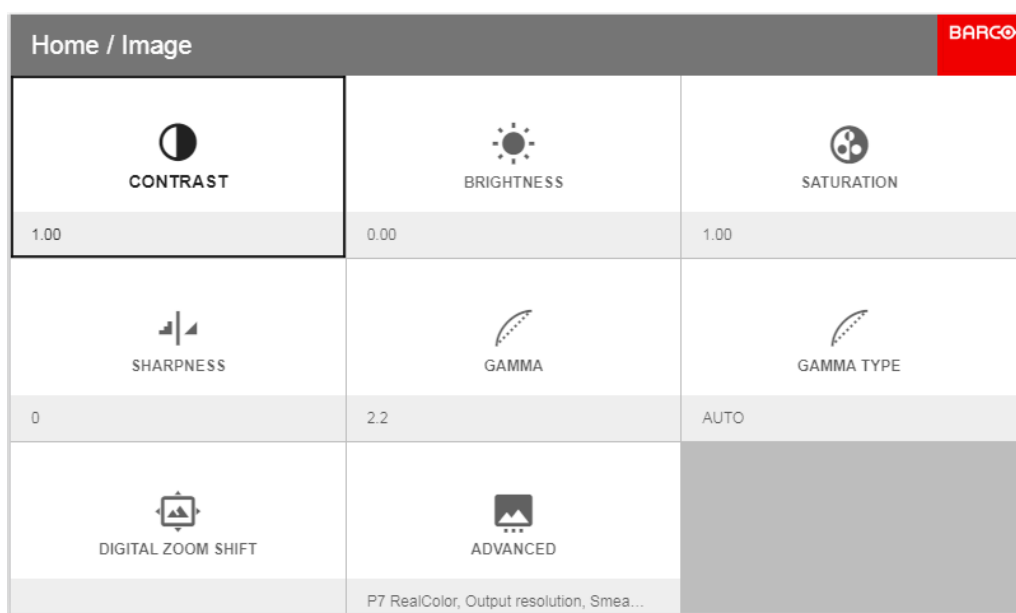

Image 7-1

Entering Contrast, Brightness, Saturation, Sharpness or Gamma menus from the keypad.

When entering any of these menus from the Keypad, the screen below will show up in the LCD panel. Use the arrow keys to select and adjust the values.

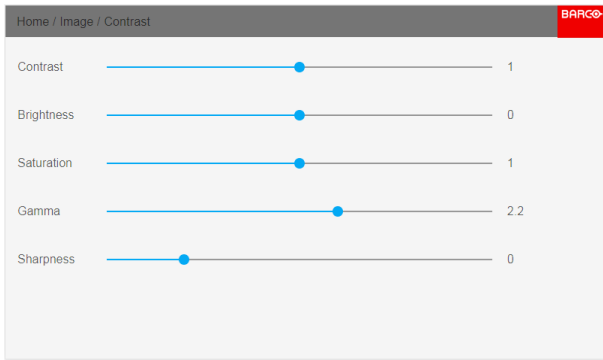

Image 7-2

7.1 Contrast

About

Image / Contrast

Used to adjust the contrast ratio of the displayed image by applying gain to the red, green and blue signals.

Available range: 0.00 to 2.00

Default value: 1.00

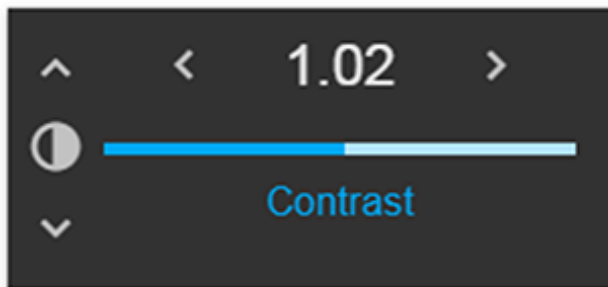

Image 7-3: Contrast OSD menu



When inside this menu, it is possible to change to the other image adjustments (Brightness, Saturation, Sharpness and Gamma) by using the up and down arrows on the remote control or keypad.

7.2 Brightness

About

Image / Brightness

The brightness function is used to adjust the black level in the input picture. It adds or subtracts an offset, or bias in to the red, green and blue signals.

Available range: -1.00 to 1.00

Default value: 0.00

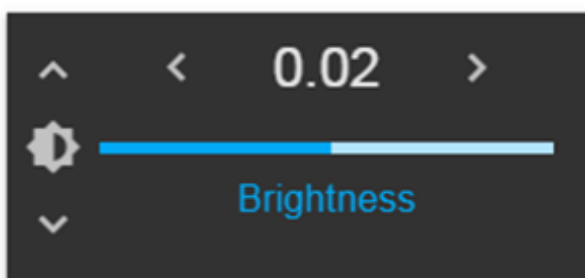

Image 7-4: Brightness OSD menu

7.3 Saturation

About

Image / Saturation

Saturation levels impact on the white levels and the intensity of the color display; the higher the value, the more vivid the color display will be.

Available range: —1.00 to 2.00

Default value: 1.00

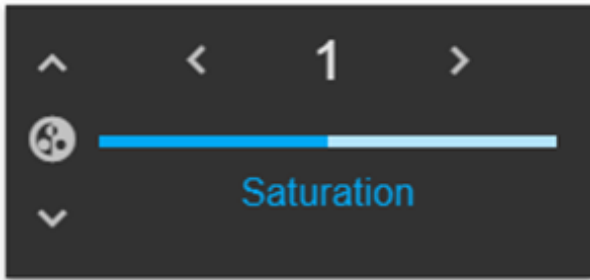

Image 7-5: Saturation OSD menu

7.4 Sharpness

About

The sharpness adjustment amplifies the high frequency components in the picture, meaning that by increase the sharpness, the picture will be perceived as sharper, and if decreased, the picture will be perceived as more blurry.

Increasing the sharpness will have the best effect in high contrast images, eg a table with text and borders.

In a natural picture, high sharpness can be perceived as noise, as all details in the picture will be amplified.

Available range —2 to 8.

Default value: 0

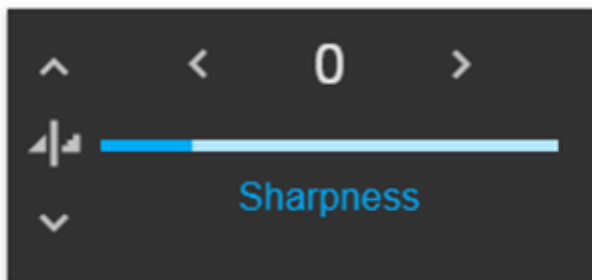

Image 7-6: Sharpness OSD menu

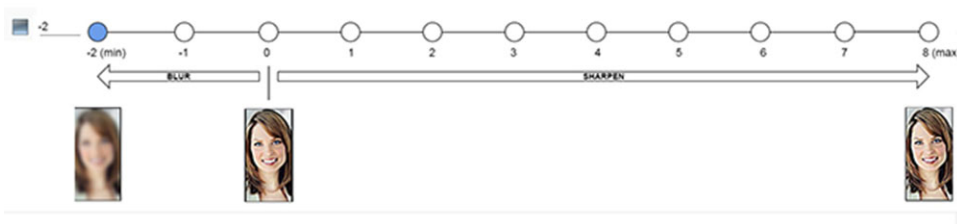

Image 7-7: Effect of sharpness adjust

7.5 Gamma adjustment

About gamma correction.

Gamma compensation, or gamma correction, is a way of adjusting the signal input to light output characteristics of a display or projector in order to suit the eye's sensitivity to different light levels and to compensate for non-linearities in displays. Without gamma compensation, images may look too dark or too

bright, lack detail or depth. By adjusting the amount of gamma compensation changes, you change only the perceived brightness levels.

Different types of displays have different gamma factors that need to be corrected in order to look and be perceived the same. For example, an MS Windows generated image displayed on a CRT monitor will require a gamma correction value of about 2.5 to avoid color bleaching and burning.

The gamma curve correction formula is based on output level \propto input level $^{\wedge}$ gamma.

1. Enter the menu *Home/Image*, and select Gamma.
2. Use the arrow keys to adjust the Gamma value, until the colors seems to be perceived correctly. The default value is 2,2.

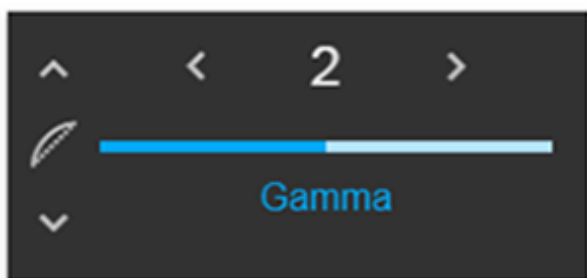

Image 7-8: Gamma OSD menu, adjusted to value 2.

7.6 Gamma Types

7.6.1 Predefined Gamma types

About

The Gamma Type selection contains several predefined Gamma settings for the most common user cases.

How to select Gamma type

1. Enter the menu *Home/Image/Gamma type*
2. Press enter, and scroll down in the menu and select the proper Gamma value.
3. Select the gamma type that match the setup in the source to obtain an optimal rendering.

7.6.2 DICOM Gamma



The Gamma slider in the Gamma menu *Home/Image/Gamma* will be disabled when DICOM, SIM or SRGB values is selected.



This function is not intended for determination of medical diagnoses.

Purpose

DICOM gamma type will not make the projector a fully certified as a medical display. For that purpose, a type of calibration must be performed, which the projector does not support.. Because of that, this function is mainly intended for educational and lecture purposes.

The DICOM function is used to simulate DICOM gammas at a few selected max light outputs, and assumes that both ambient light and the projector black is 0 cd/m².

How to select the optimal DICOM Gamma

1. Enter the menu *Home/Image/Gamma type*

2. Press enter, and scroll down in the menu and select a DICOM value that is closest to the value from the source. (If the source is set up with a value of 270, select DICOM 250 from the drop down menu). Higher numeric value represent a brighter environment.

Note:
The Gamma slider in the Gamma menu *Home/Image/Gamma* will be disabled when DICOM, SIM or SRGB values is selected.

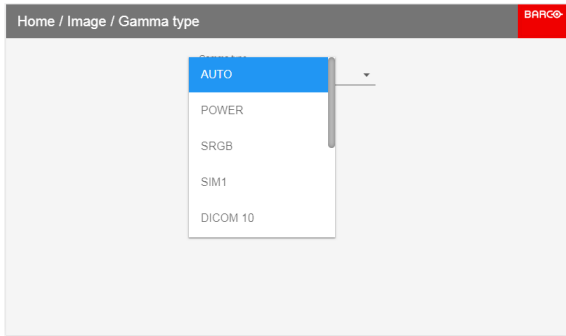

Image 7-9: Gammatype scroll down menu

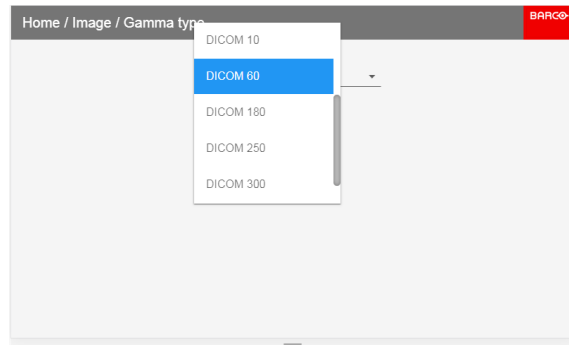

Image 7-10: Gammatype scroll down menu

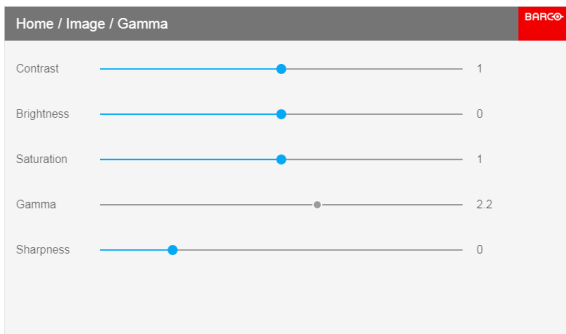

Image 7-11: Gammaslider not active when DICOM is selected.

3. Verify that the selected value gives a proper rendering of the image. If not, select another value.

7.7 Digital Zoom Shift

About

The digital zoom and Digital Shift functions are both entered from the same menu. The menu shows how to toggle between zoom and shift adjustment.

Enter the menu shown below, either via the Remote control or the keypad.

The combined menu is showed below.

The symbols on the lower part of the menu are symbols showing how to operate the keypad / remote control for the digital shift / digital zoom modes..

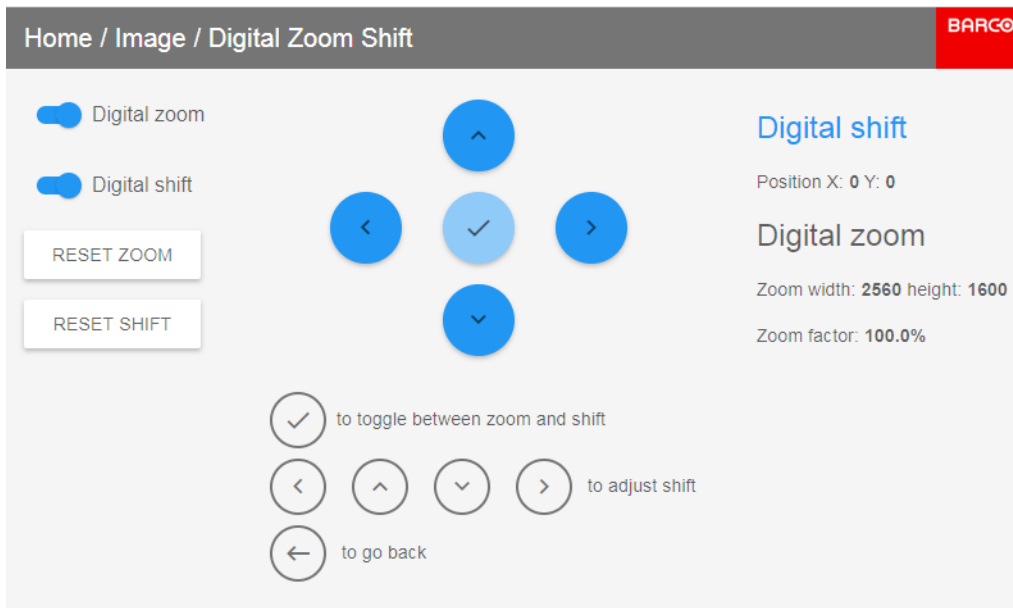

Image 7-12

7.7.1 Digital Zoom

Digital Zoom

This function zooms the picture digitally. When zooming in, the center of the image will increase in size. This means that the outer part of the picture will be outside the projector's picture frame. When zooming out, the result is that the picture will be smaller than the projector's picture frame. The area outside the rendered picture will then be black.

See the illustrations below. The red lines in the figures represent the DMD outline.

Enter the menu showed above and toggle the Digital zoom switch. Select the slider according to the instructions in the menu and move it to the desired zoom level.

The numbers on the right side of the menu represent the "new" resolution of the picture (assuming that the whole picture should be visible) in pixels. The aspect ratio will not be affected by the zoom function.

This function can also be used in combination with digital shift.

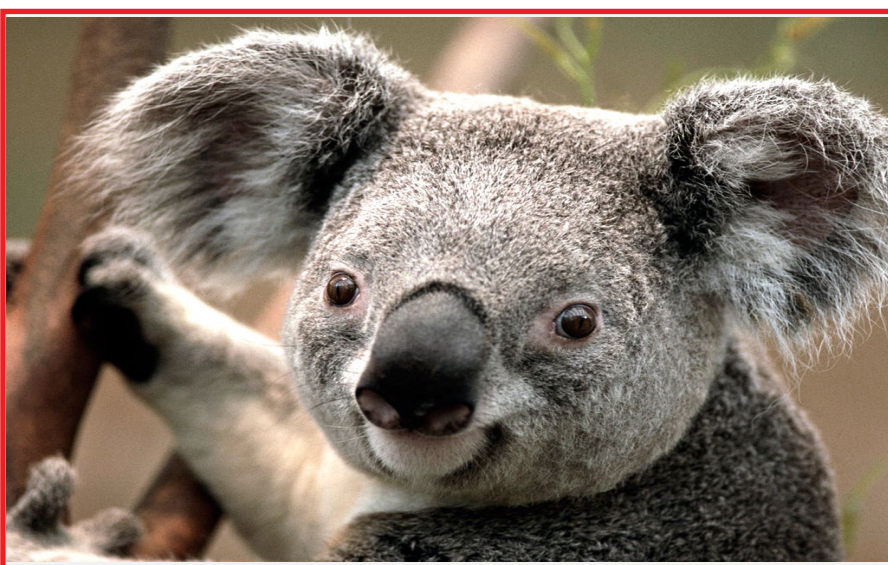

Image 7-13: Originally picture, not digitally zoomed



Image 7-14: Picture digitally zoomed in

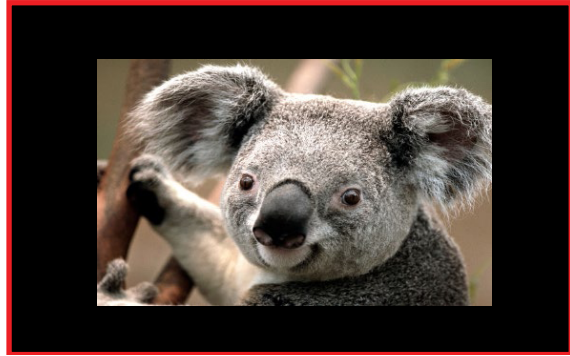

Image 7-15: Picture digitally zoomed out

7.7.2 Digital Shift

Digital Shift

This function will shift the picture digitally, meaning that the picture will be moved in any direction. As a result, some parts of the picture might be shifted outside the DMD range.

See the illustrations below. The red lines in the figures represent the DMD outline

Enter the menu showed above and toggle the Digital shift switch. Select the slider according to the instructions in the menu and move it to the desired shift level.

The numbers on the right side of the menu represent the movement (shift) of the picture in pixels referred to the "no shift" position. Positive numbers are shift right/down, and negative numbers are shift left/up.

This function can also be used in combination with the Digital zoom function.

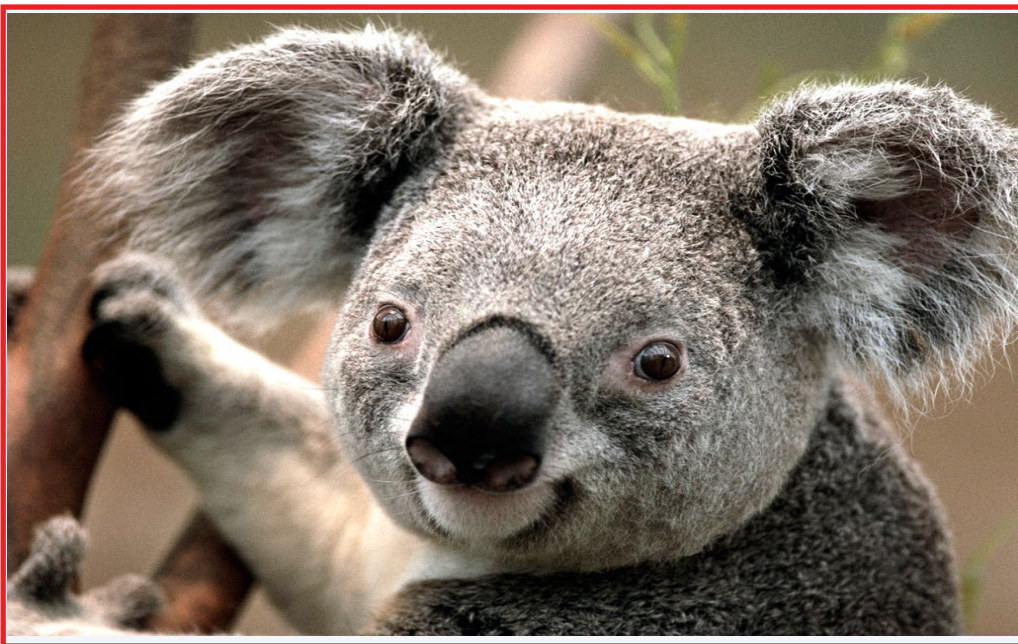

Image 7-16: Original Picture, not digitally shifted



Image 7-17: Picture shifted horizontally

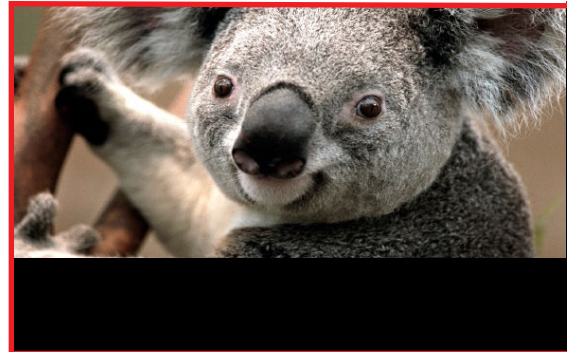

Image 7-18: Picture shifted vertically

7.8 Advanced image adjustments

7.8.1 P7 Realcolor

Purpose

When blending images from multiple projectors, the perceived color coordinates of each projector can be altered to a desired common level, so that the projected colors are identical over all projectors used.

Alternatively, if you are unfamiliar with how adjusting the Colors to a specific setting, there are also a certain number of presets available, which forces the color output to specific color standards.

How to choose one of the P7 presets

1. In the main menu, select *Image* → *Advanced* → *P7 Realcolor*.

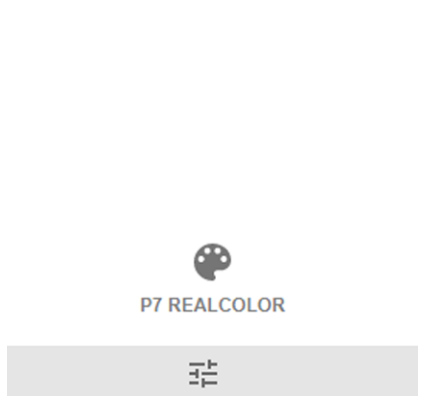

Image 7-19: Advanced menu — P7 Realcolor

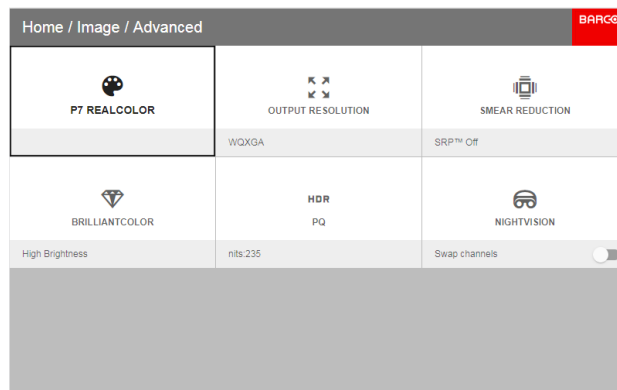

Image 7-20

The P7 menu is displayed.

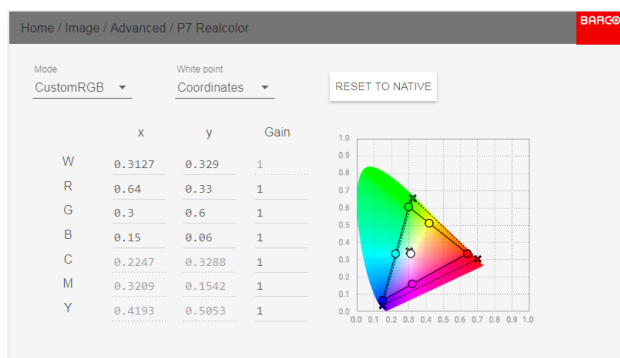

Image 7-21

2. Choose one of the pre-defined presets:
 - **Native:** Projector native color settings. Default setting
 - **EBU:** European color standard for broadcasting
 - **SMPTE-C:** American color standard for broadcasting.
 - **Rec. 709:** Color standard for high-definition televisions (HDTV).

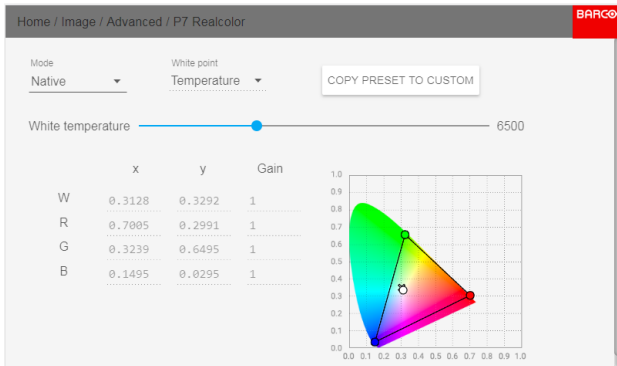



Image 7-22

 **Note:** When choosing one of the presets, All other options in the P7 menu are disabled.

How to set custom P7 values

1. In the main menu, select *Image* → *Advanced* → *P7 Realcolor*.
The P7 menu is displayed.
2. Select the desired *Mode*. Choose one of the following *custom* options:
 - **Custom RGB:** 3–point color configuration.
In RGB mode, the C, M and Y coordinates will be calculated automatically based on the R, G and B coordinates.
 - **Custom RGBCMY:** 6–point color configuration (both RGB and CMY).
In RGBCMY mode, each color can be given a specific coordinate within the measured color triangle.
 - **Custom WHITE:** Configure only the White temperature.
3. Define the coordinates for each available color.

Click on a coordinate value and select the current value. Enter the desired value with the numeric keys.

 **Note:** You can only pick coordinates within the measured color triangle.

4. For **Custom White**, click on White point and choose one of the following:
 - **Coordinates:** Configure the white point via specific coordinates.
The white point is specified using an x, y coordinate in the CIE 1931 Chart.
 - **Temperature:** Configure the white point via a color temperature slider.
The white point is specified on a Kelvin scale between 3200K and 13000K tracking along the black body curve.

 You can reset all coordinates to the default values (to native) by selecting Reset modes to native. Press **OK** button to reset.

7.8.2 Edit the RealColor presets.

Editing presets

The different presets in the Real Color menu can be edited to obtain an optimal rendering of the picture.

Enter the menu *Home/Image/Advanced/P7 Realcolor*.

Select the desired preset mode (EBU, Rec709 or SMPTE-C) and select the coordinate within each color component that has to be corrected. Enter the desired value either by:

- Using the keypad to increase /decrease the selected value by the arrow keys.

- Using the remote control: Erase the existing value with the “ * ” key, and enter the new value by the numeric keys.

The values are stored for the preset, until the “Reset” button is enabled, or when a factory reset is performed.

There is also a possibility to store the values in the custom presets.. Press the “Copy preset to custom” button to save.

The edited presets can be reset to the original values by enter the Reset button. There is also a possibility to copy the values to the custom preset.

To reset the values in Custom presets, enter the “Reset to native” button when in Custom mode

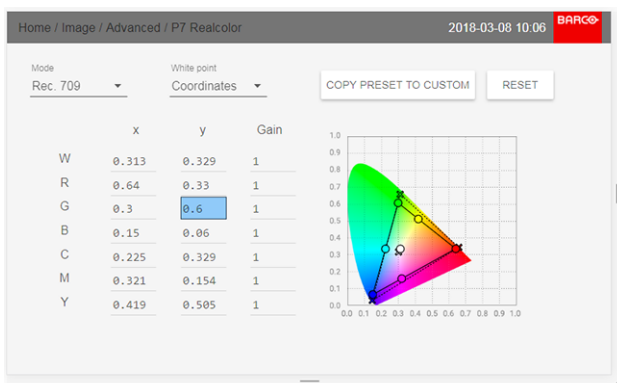

Image 7-23: Change coordinate values.

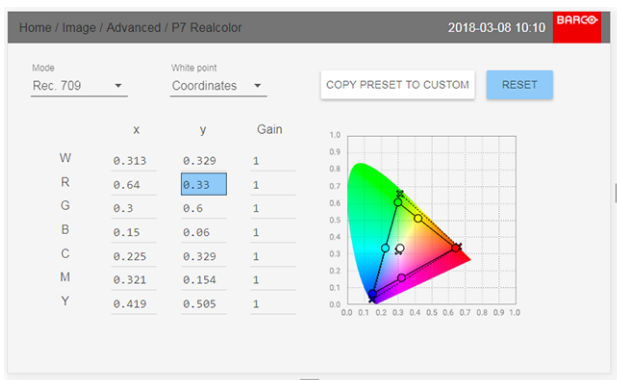

Image 7-24: Reset the edited values to original

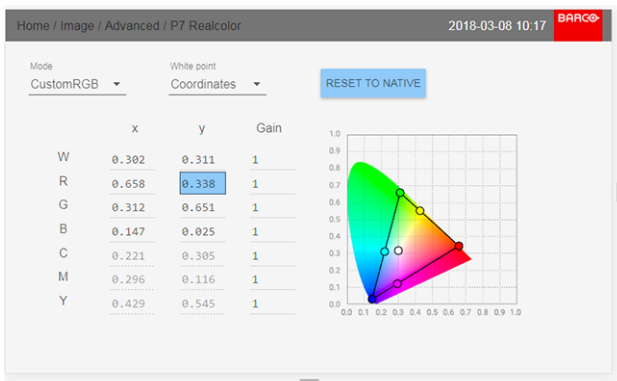

Image 7-25: Reset the custom values to original

7.8.3 Output resolution 4K

About

With this function, the projector output resolution can be changed between 4K UHD resolution and WQXGA resolution.

Refer to the chapter “Projector source and control connections” regarding use of input sources in 4K mode.

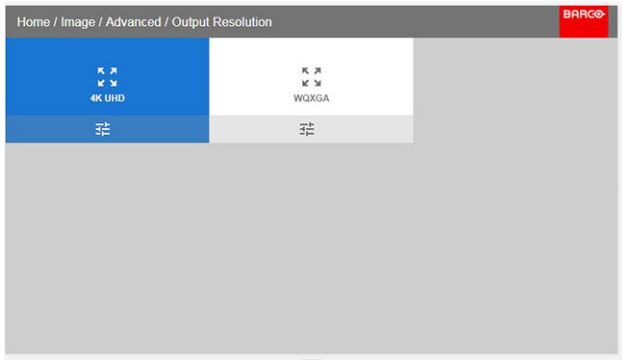

Image 7-26: Output resolution menu

7.8.4 Smear reduction

About

Smear is a phenomenon that typically occur when objects in the picture moves in high speed over the screen. It appears like there is a “tail” behind the object, or a lag in the moving parts of the picture.

In order to avoid this, there has been developed a Smear Reduction Process (SRP™), that reduces this perceived rendering. Select the option that give the best result.

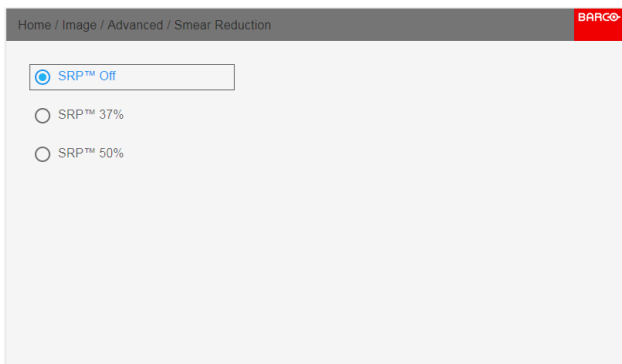

Image 7-27: SRP Menu for WQXGA

7.8.5 Brilliant color

About

Optimizes the color rendering, by adjusting the light intensity. This has the effect of changing the color intensity, and by that also the perceived light intensity.

Enter the menu, and select the option that give the best result

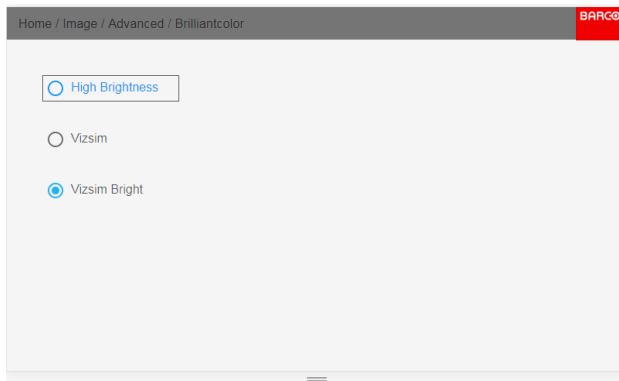

Image 7-28

7.8.6 Displaying HDR content– Perceptual Quantizer (PQ)

About PQ

Perceptual Quantizer (PQ) is a non-linear electro-optical transfer function (EOTF) that allows for the display of High Dynamic Range (HDR) content with a luminance level of up to 10 000 cd/m² and can be used with the Rec. 2020 color space.

How to properly display HDR content?

If your provided HDR content has been mastered with PQ (e.g. HDR10 and Dolby Vision), a few changes can be made in order to project the intended mastering on screen. These changes are necessary because HDR content has been mastered specifically for HDR capable displays that are watched in living rooms. These conditions are different from a non-HDR projector and darker cinema-like environments.

The projected HDR content depends on the following factors:

- **Mastering luminance:** This is content-specific and cannot be changed.
- **Screen luminance:** Every projection screen has a specific luminance (measured in nits or foot-lambert). Entering this luminance in the projector will adapt the content towards the intended HDR result.
- **HDR Boost:** A variable “booster” that may amplify or downplay the HDR output.

How to set the PQ?

1. In the main menu, select *Image* → *Advanced* → *PQ*.

The PQ menu is displayed.

2. Select the desired Unit (nits or foot-lambert).
3. Enter the Screen luminance (either in nits or foot-lambert).
4. Alter the HDR boost if necessary. You can modify this value to somewhere between 0.8 and 1.2.

7.8.7 HDR Status.

When an active source is HDR, an icon is visible in the status menu.

The HDR icon will also be visible in the “Source signal popup” icon in the lower right corner on the screen.

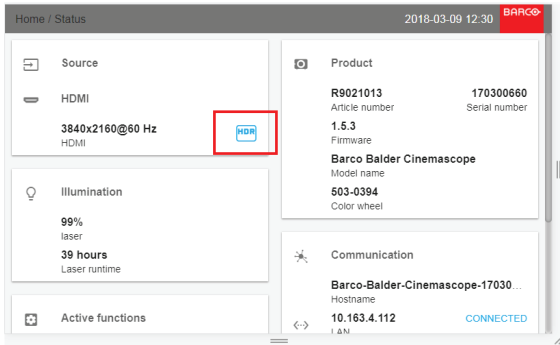

Image 7-29: HDR Icon.



Image 7-30: Source signal popup icon.

7.8.8 Nightvision

About

When using e.g. displayport 1 as daylight image input, and displayport 2 as nightvision input, this option make it possible to swap these two channels in the image processing in order to synchronize with the NV goggles.

How to swap channels

Select the menu *Home / Image / Advanced / Night Vision*.

Toggle the Swap channel function on / off by pressing the OK button on the remote control or the keypad.

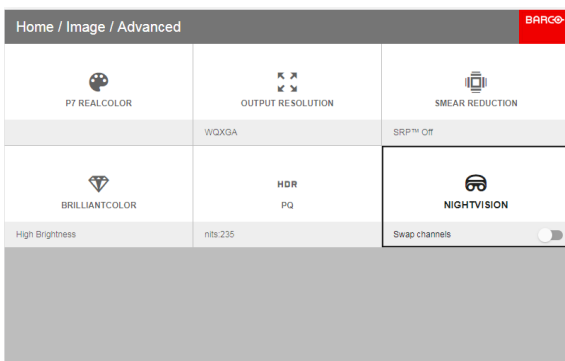

Image 7-31

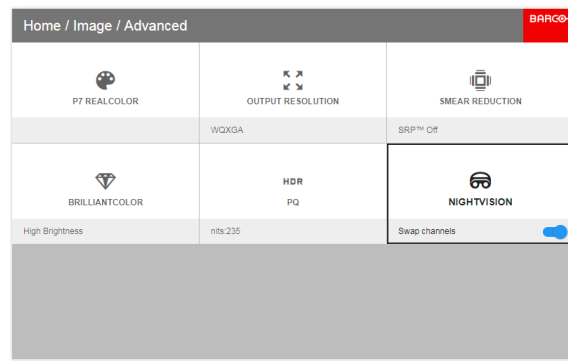

Image 7-32

Installation menu

8

Overview

- IR / Night vision functionality
- Lens
- Orientation
- Scaling modes
- Warping
- Blending
- Illumination
- CLO — constant light output
- Display setup

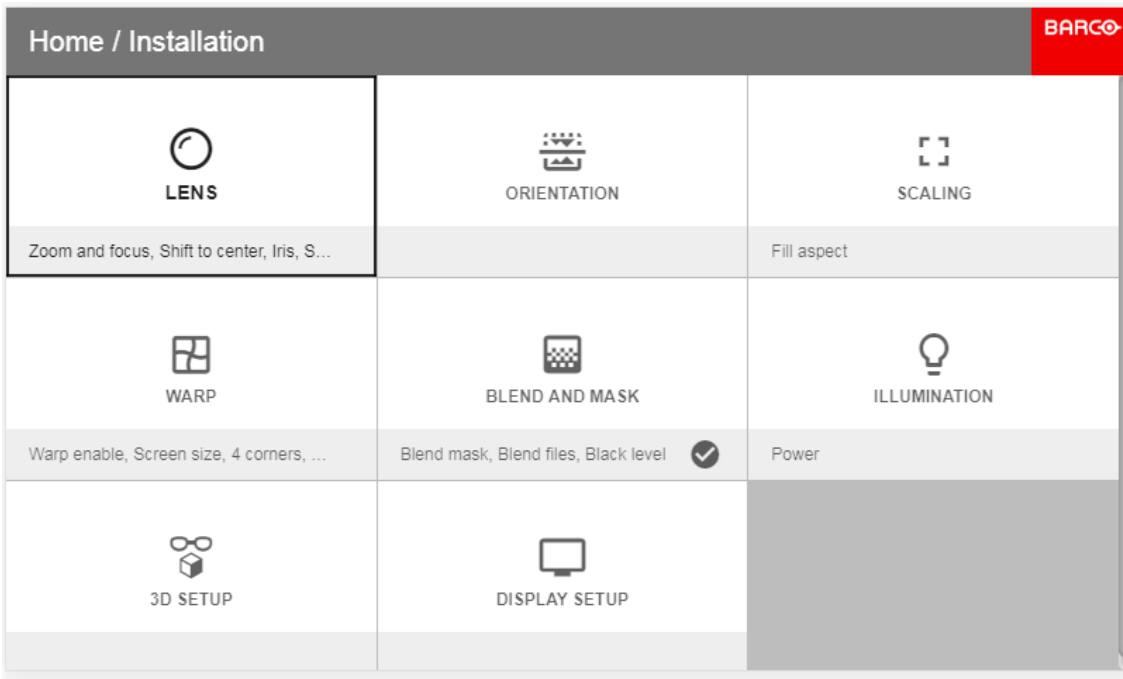

Image 8-1

8.1 IR / Night vision functionality

About

IR / Night Vision functionality is only available for the FS40 variant of the projector..

In combination with Night Vision Goggles (NVG), this will give a realistic rendering of the environment. This will visualize in a realistic way, night time, dusk and dawn, and limited visibility scenarios.

The IR light source has a wavelength of 740nm

How to enable IR/Night Vision.

Enter the menu *Home / Installation / Display setup* and select NightVision in the scroll down menu.



Image 8-2

To set up the IR illumination, enter the menu *Home/Installation/Illumination/Power*. This menu shows two sliders; one for the LED (daylight), and one for the IR LED (Night Vision). The sliders are scaled from zero – 100% power.

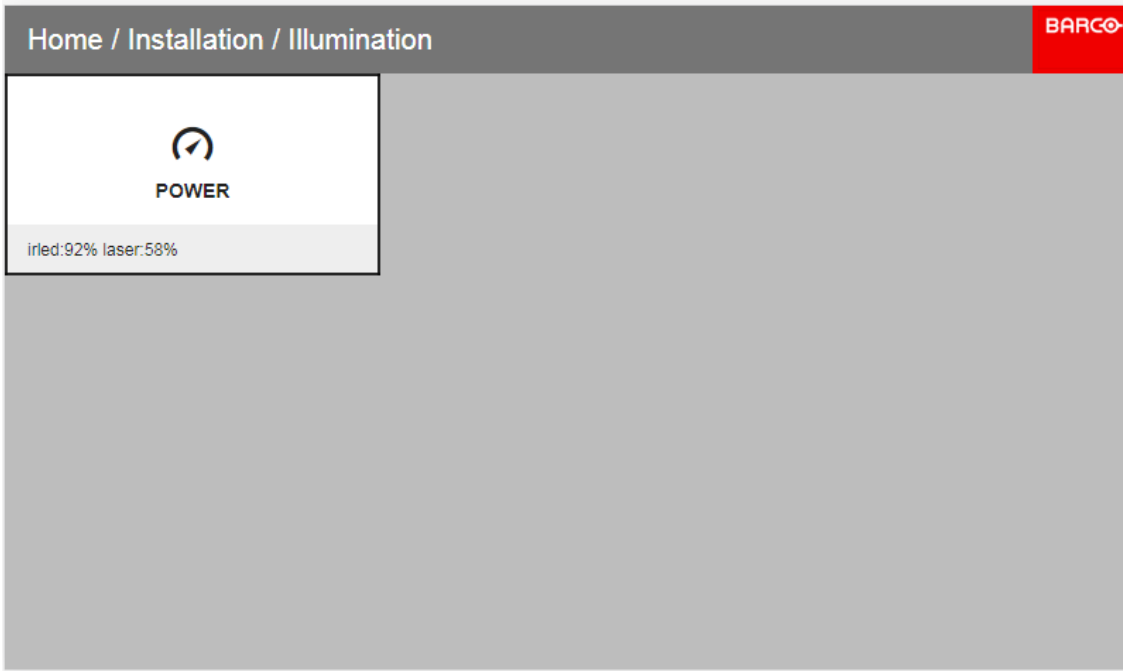

Image 8-3

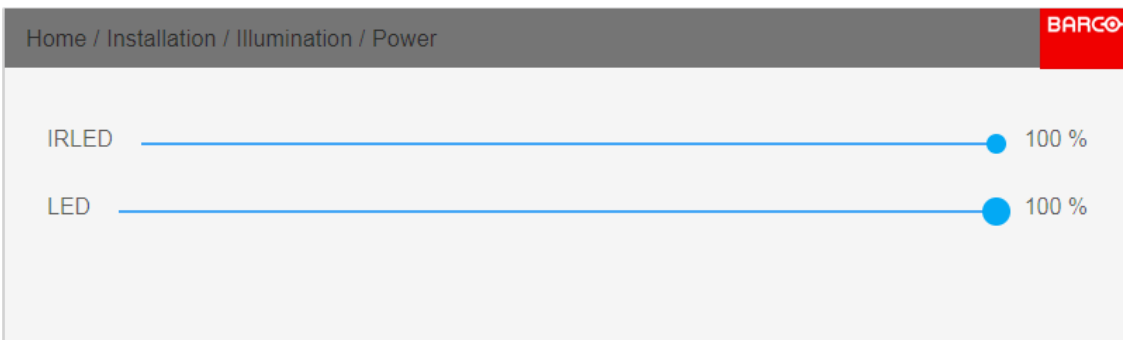

Image 8-4

Select the LED slider, and move the slider to the left by the arrow keys to nearly 0% to reduce the light intensity. (Daylight visibility). By this, the IR LED will be dominant, and the image on the screen will be visible with the Night Vision Goggles. Put on the goggles, and adjust the IR LED slider to obtain an optimal night vision rendering.

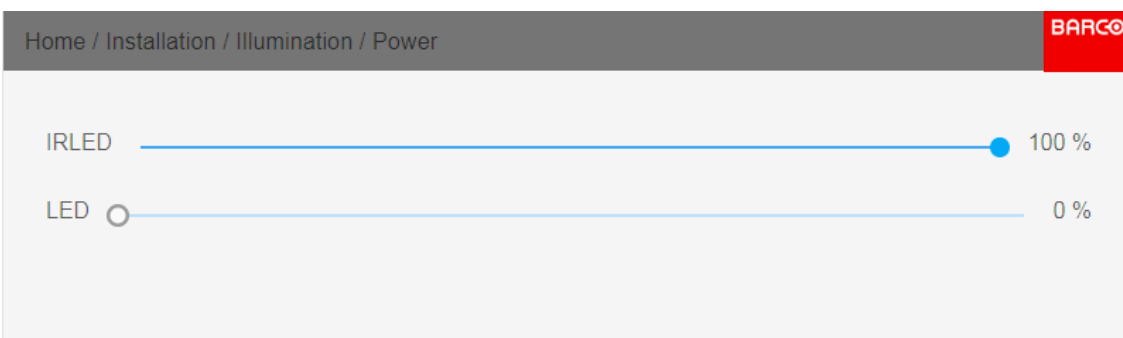

Image 8-5

By mixing the intensity (power) of both the LED and the IR LED, it is also possible to simulate other visibility scenarios, such as evening / early night vision.

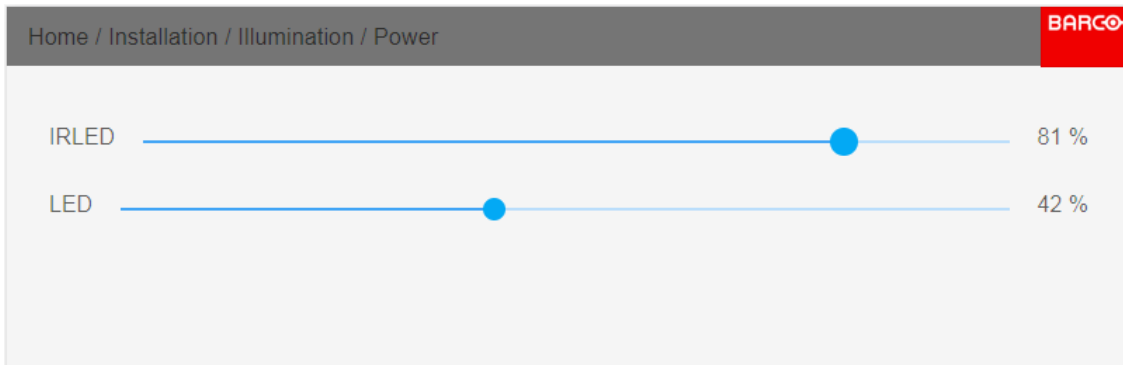

Image 8-6



When enabling IR mode (Night Vision), the Vizsim Bright will be set as default. If another approach to IR (Night Vision), is performed, e.g. by selecting Auto Stereo Mode and at the same time turn off the LED's, Vizsim Bright must be set manually. "Brilliant color", page 76 If not then set to Vizsim Bright, the picture will be distorted.

Disable this functions in IR mode

The Vizsim Bright mode will not cause this distortion.

8.2 Lens

8.2.1 Zoom / Focus

Zoom and focus

Installation / Lens / Zoom Focus

Use either the keypad arrows, or the remote control for this operation.

Use the navigational arrows, up and down, to adjust zoom.

Use the navigational arrows, left and right, to adjust focus.

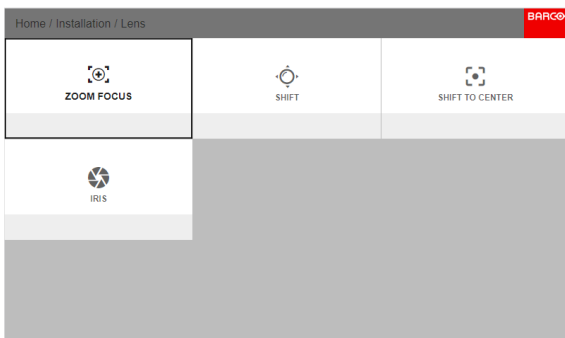

Image 8-7

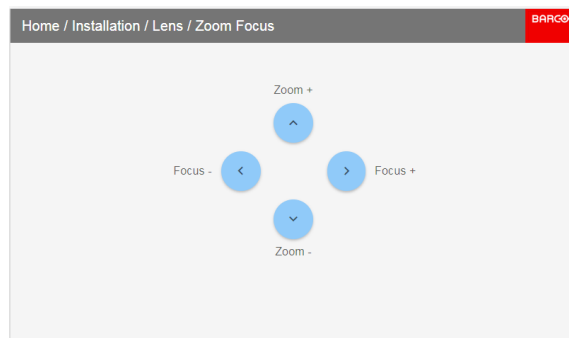

Image 8-8

General

Zoom controls the size of the projected image.

Focus controls the sharpness of the projected image.

Lens zoom and focus adjustments are motorized. You can use the remote control, local keypad, OSD and/or RS-232 commands to adjust the lens zoom and focus positions.



Not all lenses have zoom or iris control. The matrix below shows what controls are available per lens.

	E-N11	E-N12	E-N13	E-N14	E-N15	E-N16	E-N33	E-N41	E-N42	E-N43	E-N44	E-N45	E-N46	E-N47
Iris	✓	✓	✓	✓	✓	✓	✗	✓	✓	✓	✓	✓	✓	✓
Zoom	✓	✗	✓	✓	✗	✓	✗	✓	✗	✓	✓	✓	✓	✗
Focus	✓	✓	✓	✓	✓	✓	✓	✓	✓	✓	✓	✓	✓	✓

For best results, lens adjustments should be done in the following order: zoom, focus and then iris (where applicable).

8.2.2 Shift

General

The lenses can be shifted vertically and horizontally to facilitate precise image positioning in single and multiple projector systems. The projector allows for horizontal and vertical shift in both directions. Always place the projector perpendicular to the screen, and use the lens shift to align the picture.

Use the Remote control or the keypad on the Projector to adjust the lens shift mechanism.

Use the left, right, up and down navigational arrows to adjust the lens shift in four directions. This feature moves the picture optically within the shift range of the lens optics.

Press the right key to enable shift, and use the arrow keys on the remote control, or the keypad to move the picture in vertical and horizontal directions.

If not possible to align the projector perpendicular to the screen, due to environment of other, see chapter "Warp – 4 Corners adjustment", page 92

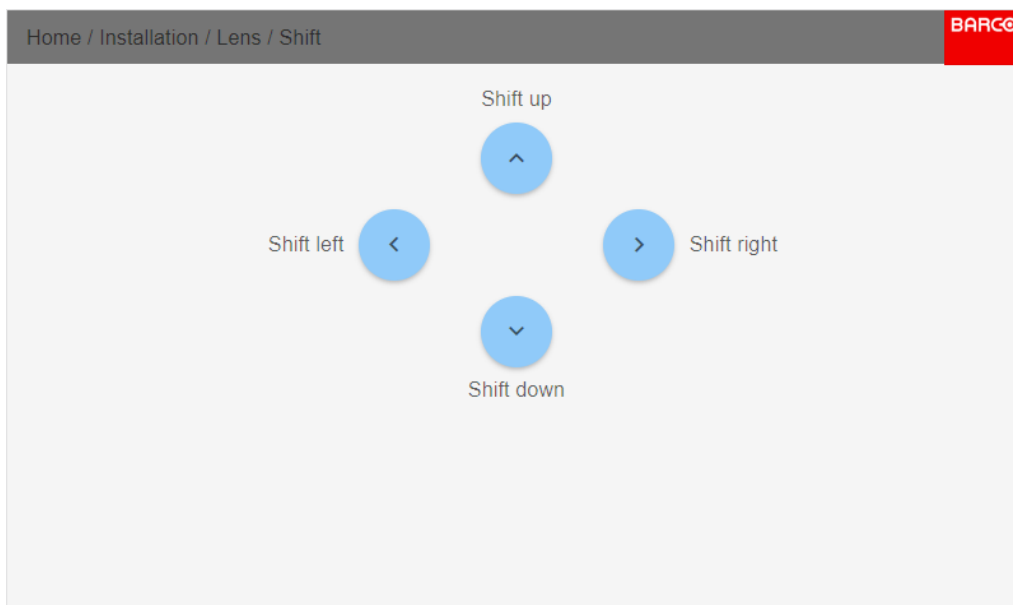

Image 8-9



When EN 68 lens is installed in the projector, there are some limitations in the lens shift range, in order to avoid damage to the lens.

This limitation will be identified as a reduction in the output light from the projector when the shift position exceeds the defined range. The output light will then be reduced to 20% of max.

8.2.3 Shift to center

From remote control

This function adjust the lens position to the mechanical mid position.

Enter the menu *Home/installation/Lens/Shift to center*

Confirm with the ✓ button on the remote control, and the “Lens shift to center position?” pop up windows shows up.

Move the highlighted rectangle to “OK”, and confirm with the ✓ key.

When EN68 lens is installed:

Due to restrictions in light output for the EN 68 lens, the mid position for this lens will not be the mechanical mid position, but the mid position of the area where max light output is allowed.

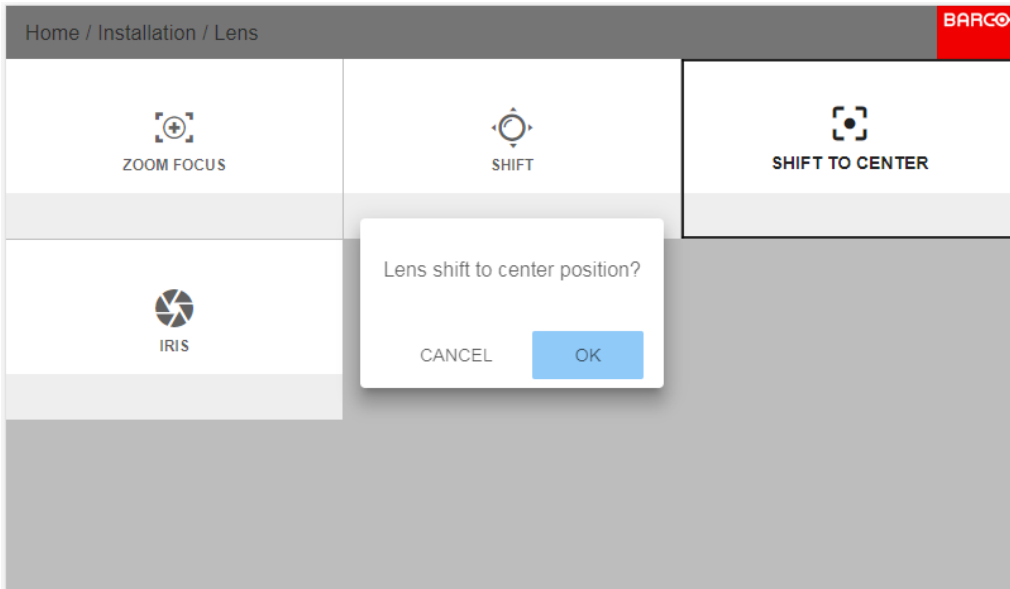

Image 8-10

From the keypad

Press the Lens button on the keypad. A menu picture as shown below shows up.

Press the ✓ button for 3 seconds.

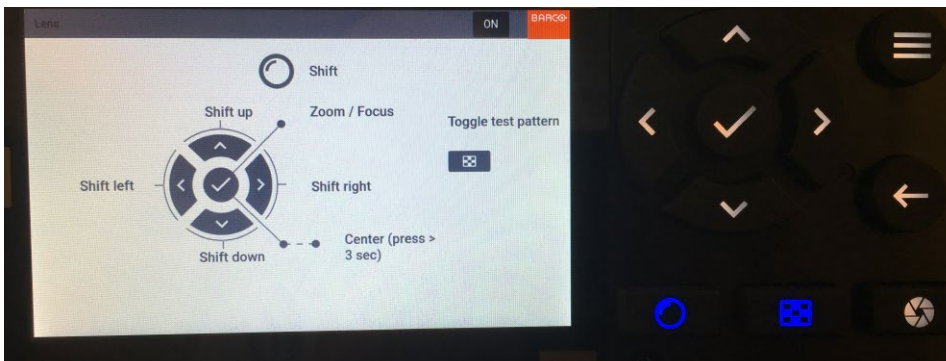

Image 8-11

8.2.4 Iris

General

Iris controls the contrast and focus depth of the image, and will also have an impact of the output light.

Decreasing the iris opening will increase contrast and image depth, at the same time as it decreases the output light.

The FL40 / FS40 projectors has two irises; One in the lens, and one in the illumination path. They have both mainly the same function, but with a small difference.

Lens iris

Located in the lens, and will increase the contrast and depth of the focus area when used. Will also have an effect of the output light

Illumination iris

Located in the illumination path, and has less, but still an effect on the contrast and the depth of the focus area, but will to a greater extent have an effect on the amount of output light.

How to adjust iris

Iris control is, as for the zoom and focus control, motorized, and is operated by the remote control or local keypad.

To enter Iris control, enter the menu *Home/Installation/Lens /Iris*

The adjustment of the iris is infinitely adjustable.

Use the arrow keys to adjust Iris until preferred rendering is obtained. The numeric value in the menu indicates the degree of opening of the iris.

Value = 0, full opening. (No iris activated).

Increased numeric value indicates decreasing in the iris opening. (Iris activated).

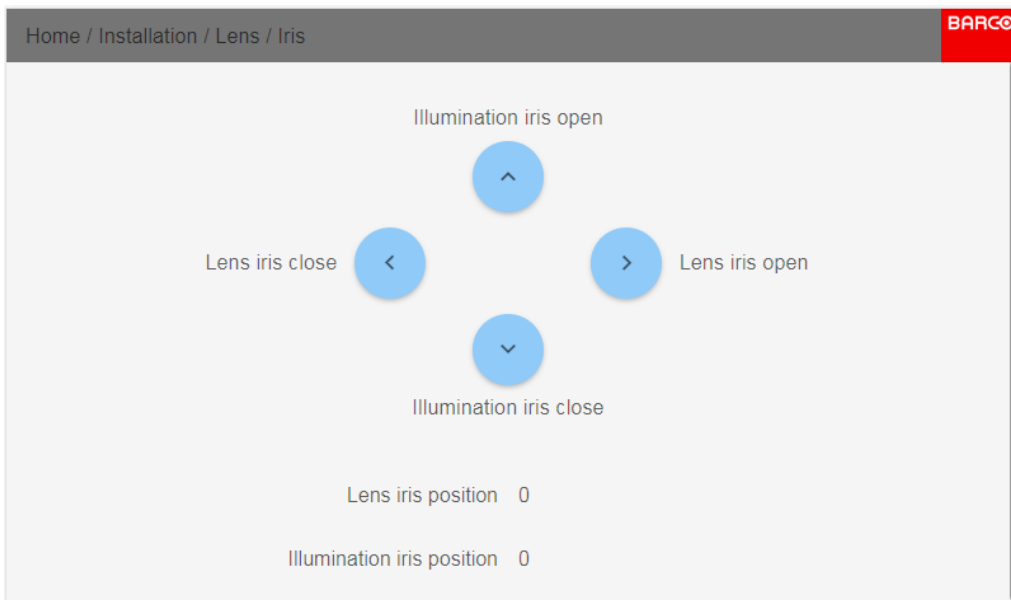

Image 8-12

8.3 Orientation

About

Installation / Orientation

Rotate the image on the imaging device depending on the physical installation of the unit.

There are four installation options, as illustrated below:

- front/table
- front/ceiling
- rear/table
- rear/ceiling

Default: Table Front.

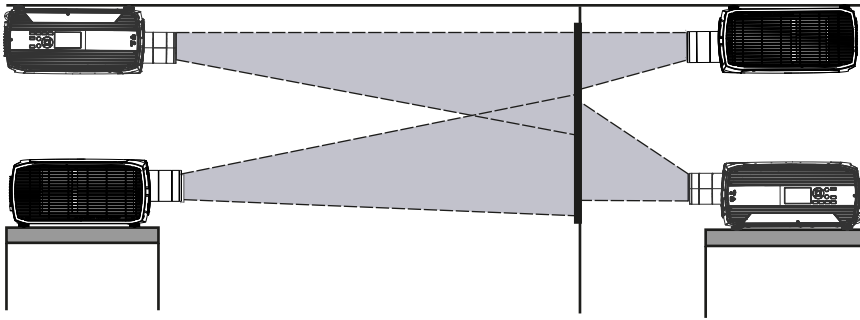

Image 8-13

How to set the correct orientation

Select Orientation from the menu

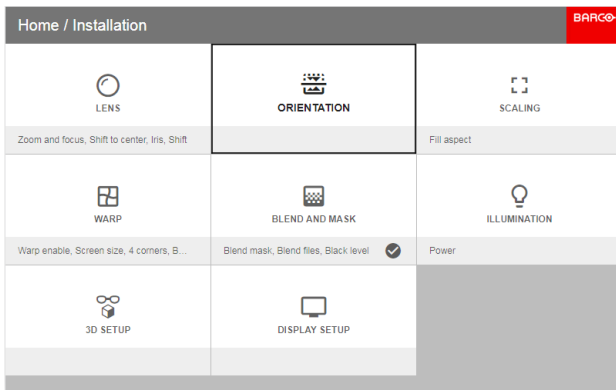

Image 8-14

The orientation menu is displayed

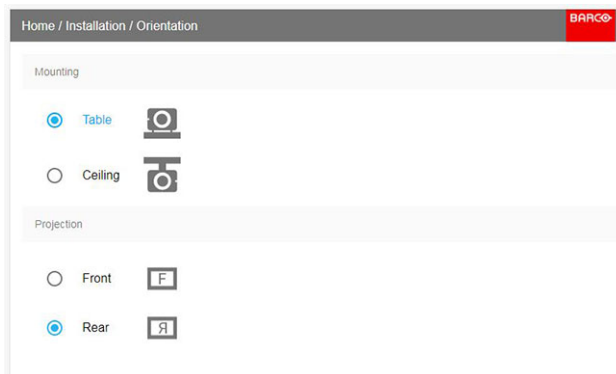

Image 8-15: Orientation Menu

Use the arrow keys to select the Mounting and Projection positions, and press OK button to activate.

8.4 Scaling modes

General



For the modes Fill Screen and Stretch, the screen size must be defined, see chapter “Warping Screen Size”.

The purpose of the scaling mode is to adapt the image on the screen in an optimal way, based on the desired rendering. The examples below shows a screen format of 2,35:1, and a DMD format 16:10. (WQXGA).

The scaling mode function has four different presets:

- Fill aspect
- 1:1
- Fill Screen
- Stretch.

The illustrations below shows the resolution for WQXGA, and a screen aspect ratio of 2,35:1 (Cinemascope format). But the principle is the same also for other resolutions and screen sizes.(4K, WUXGA / 16:10, 16:9..)

Mode Fill aspect

This mode utilizes so much as possible of the native size of the DMD, and keeps the aspect ratio.

Input signal (Source): 4 : 3

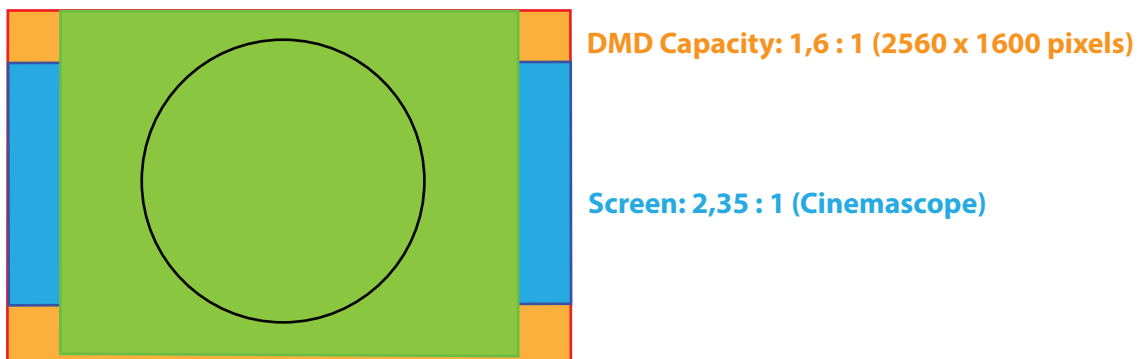

Image 8-16

1:1

This mode is an exact rendering of the source signal, pixel by pixel

Input signal (Source): 4 : 3

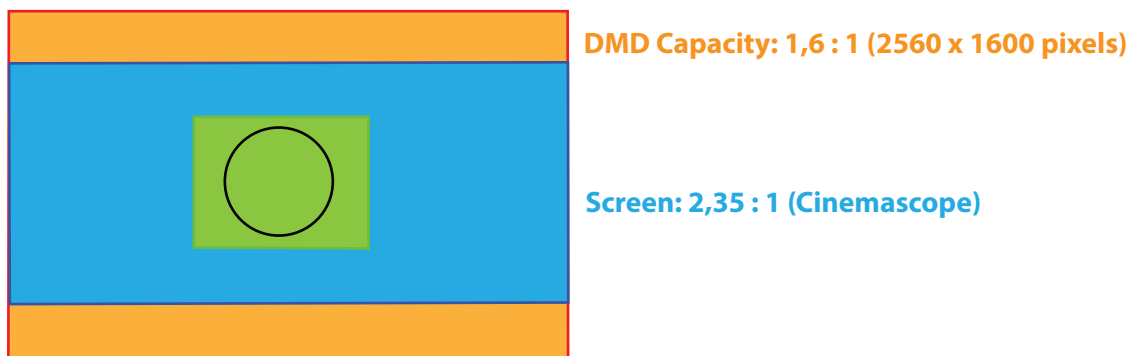
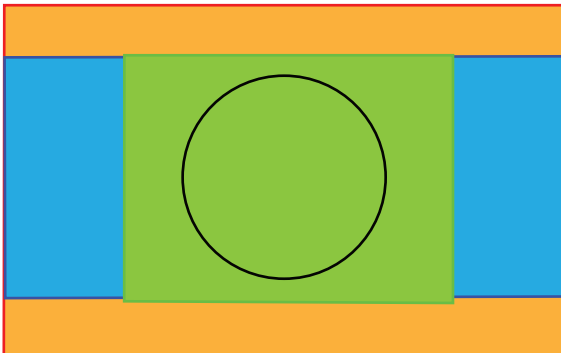

Image 8-17

Fill Screen

This mode utilizes the defined screen size, and keeps the aspect ratio.

Input signal (Source): 4 : 3



DMD Capacity: 1,6 : 1 (2560 x 1600 pixels)

Screen: 2,35 : 1 (Cinemascope)

Image 8-18

Stretch

This mode stretch the rendered picture to utilizes the defined screen size. The rendered picture will then be stretched / distorted compared with the source signal.

Input signal (Source): 4 : 3

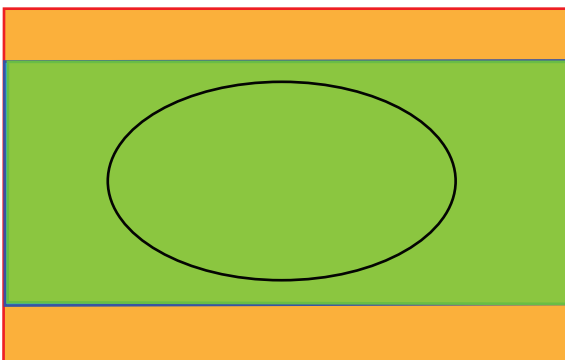

DMD Capacity: 1,6 : 1 (2560 x 1600pixels)

Screen: 2,35 : 1 (Cinemascope)

Image 8-19

How to enter.

Enter the menu *Home/Installation/Scaling*

Select the desired mode and press OK button on the remote control or keypad.



Image 8-20

8.5 Warping

8.5.1 About warping

About

Image warping is the process of digitally manipulating an image to compensate for the distortion of the screen, typically by non perpendicular alignment of the projector versus the screen. The image will then typically occur as shown in Image 8-21.

While an image can be transformed in various ways, pure warping doesn't affect the colors.

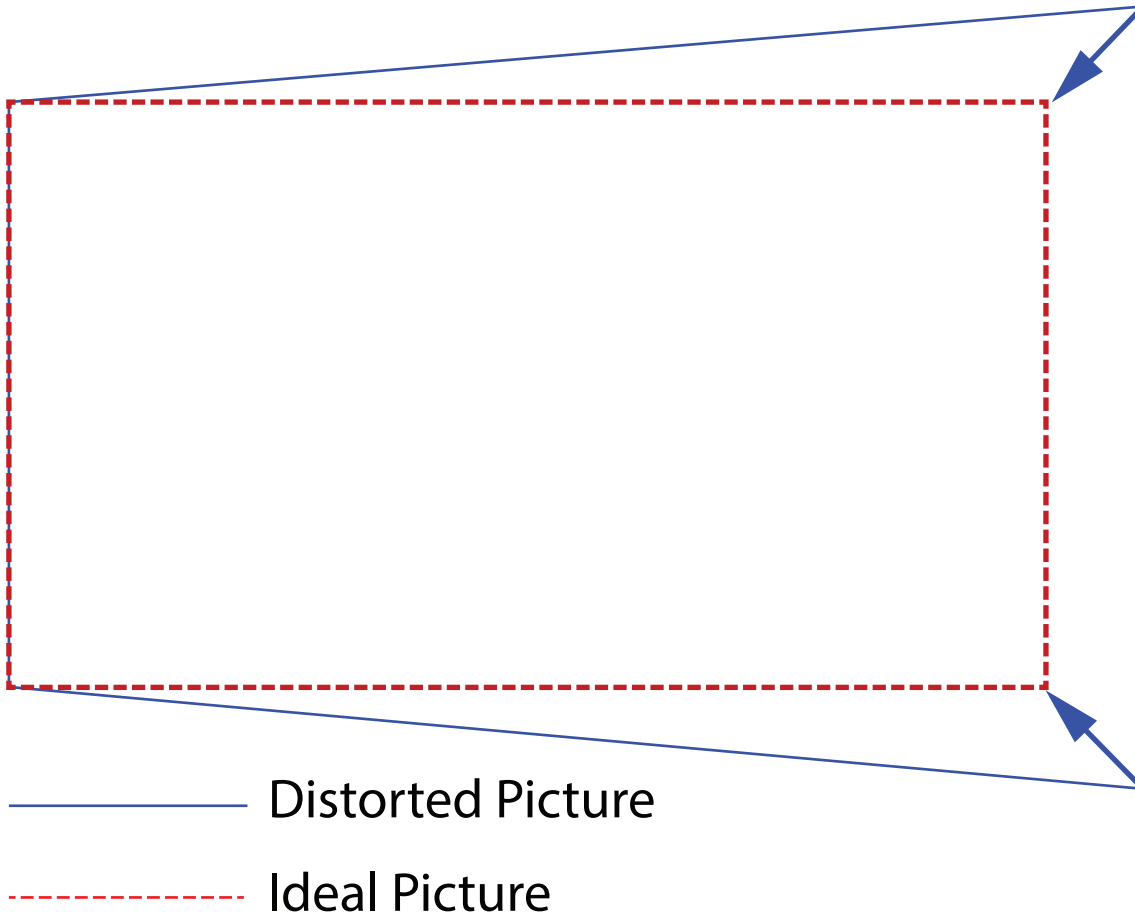

Image 8-21

8.5.2 Warping – On/Off

About warping on/off

By toggling between on and off the warping functionality can be enabled or disabled.

How to toggle

1. In the main menu, select *Installation* → *Warp*.



Warp, Screen Size, 4 Corners, Bow, Files

Image 8-22: Installation menu, Warp

The Warp menu is displayed.

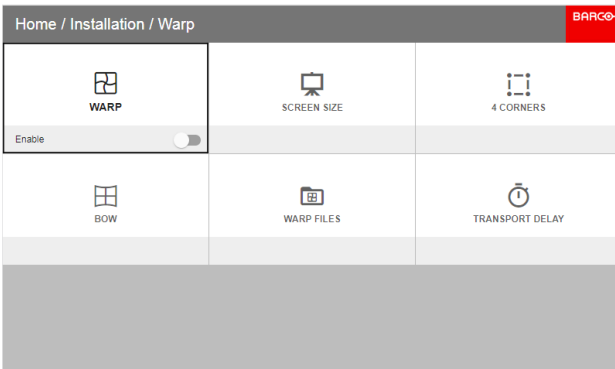

Image 8-23

- In the Warp menu, click *Warp* to toggle between *On* and *Off*.



Image 8-24



Image 8-25

8.5.3 Warping – Screen size

About (Warp) Screen Size adjustment

If the used screen aspect ratio is different than the projector aspect ratio, e.g. source is 16:9 and projector is 16:10, then black bars will be projected. In the example case a black bar on top and bottom of the image will be projected. The warp area contains not only the image information but also the black bars. If we want to position e.g. the active left top corner exactly on the screen using 4 corner warp, then it is very hard to do that as we are moving the black left top corner and we do not have control over the exact position of image left top corner. By moving the outline of the warp screen size to the active image information, the corner points of the warp area are now exactly on the corner points of the active image information and makes warping much easier.



Image 8-26: Warp outline example

How to adjust the image?

1. In the main menu, select *Installation* → *Warp* → *Screen Size*.



Image 8-27: Warp Menu, Screen Size

The Screen Size menu is displayed.

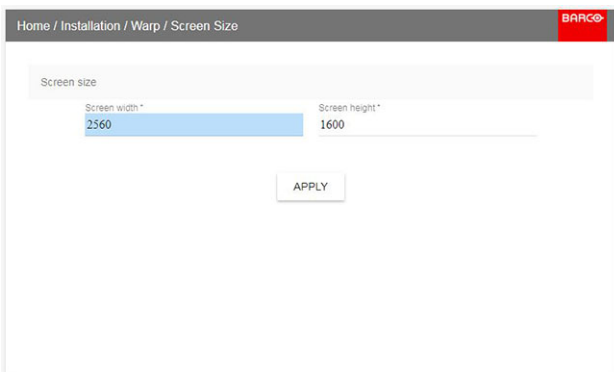





Image 8-28

2. Select either *Screen width* or *Screen height*.
3. Set the screen size width and height to match the measurement of the screen.

-  **Note:** It is only the ratio between the width and height that is used, so the values may be entered as the screen aspect ratio or actual measurement in cm, inches or any other unit.
-  **Tip:** A red border will be projected along with the current image. The border is a visual tool, showing the result of the adjusted outline.
-  **Tip:** The value can also be entered by the numeric keys on the remote control. Press * to delete existing numbers, and enter the new value by the numeric keys.

4. Click **Apply**.

8.5.4 Warp – 4 Corners adjustment

About 4 Corners adjustment

Basically, this type of warping adjusts each of the four image corners in the X and Y direction, if you have a typical trapezoid picture of the screen as shown below.

To have a successful Warp correction, the size of the screen must be entered. See “Warping – Screen size”, page 90

Some examples of pictures when the projector axis is not perpendicular to the screen.:



Image 8-29

How to adjust the image.

1. From the warp menu, select the 4 Corners Menu. A yellow frame will be visible.

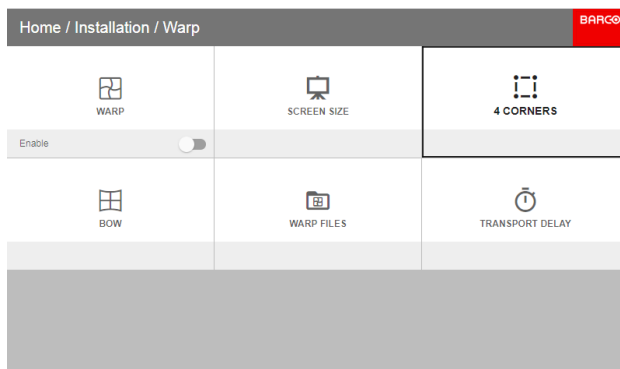

Image 8-30

2. To enable the 4 Corners Warping, Set the Warp slider to the right position. (Select and enter).
3. Select the corner that must be warped. If need for warping several corners, select and adjust the corners one by one.

Adjust the value by the arrow keys. The value represent the movement of the X and Y coordinates for each corner. When the warping is complete, exit the menu by using the “Back” button.

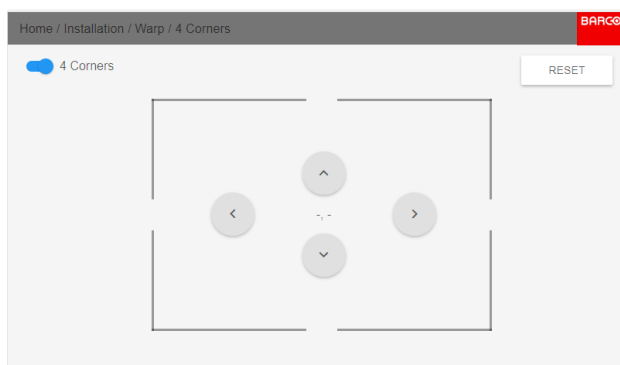

Image 8-31

- If the picture still has a trapezoid shape, warp is not enabled. Select the *Installation / Warp* menu, and press enter. The slider moves to the right, and the warp status changes to “On”.

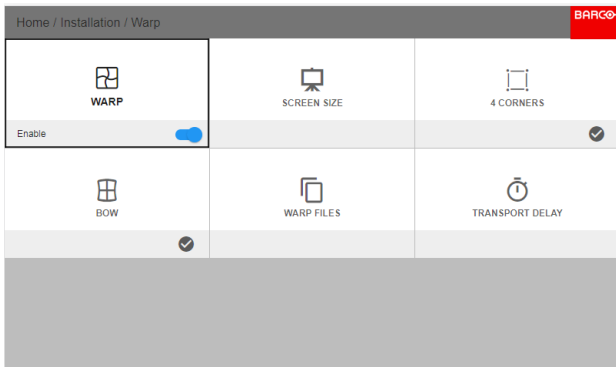

Image 8-32

8.5.5 Warping – Bow

About bow adjustment

A bow distortion can be adjusted so that a normal image is displayed. Positive adjustments angles introduce more outside bow distortion. Negative adjustments introduce more inside bow distortion.

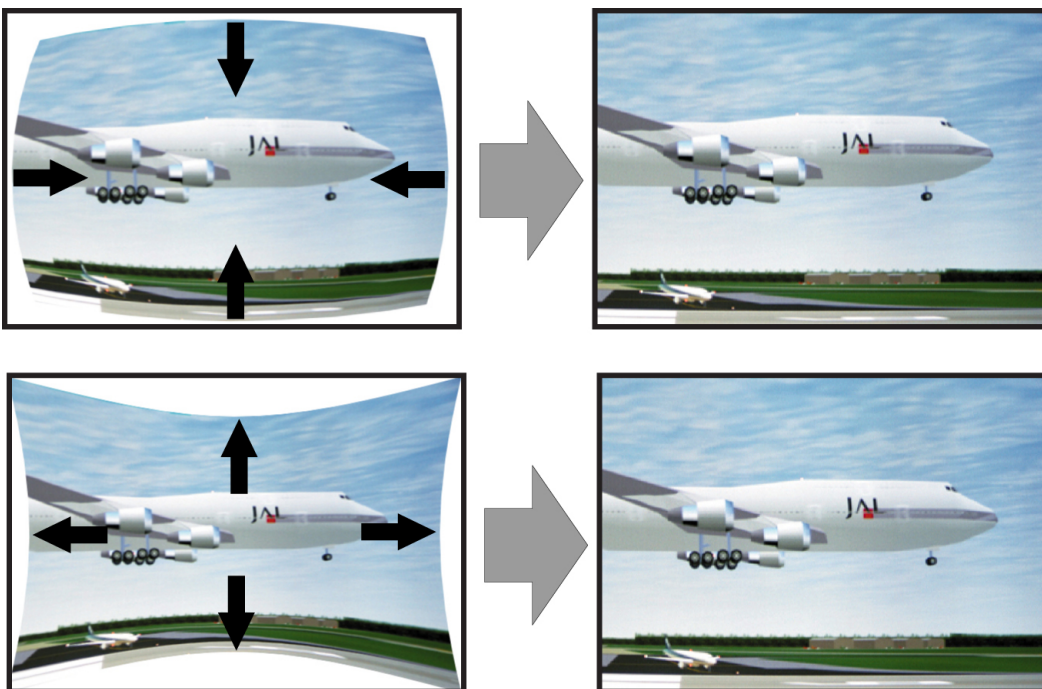

Image 8-33: Bow distortion

Symmetric bow correction

- In the main menu, select *Installation* → *Warp*.



Warp, Screen Size, 4 Corners, Bow, W...

Image 8-34: Installation menu, Warp

2. In the Warp menu, select *Bow*.



Image 8-35: Warp menu, Bow

A check symbol at the bottom right corner indicates that the bow function is activated.

When the bow menu is selected, a grid will occur in the screen picture in order to visualize the adjustments performed.

3. To enable Bow correction, make sure the *Bow* slider is set to *On*.
The slider is enabled when set to the right and when it is highlighted blue.

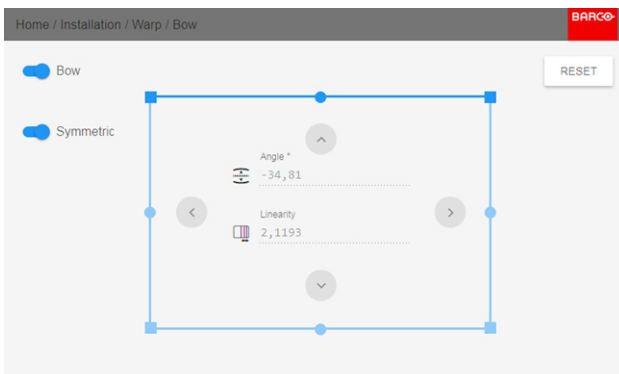

Image 8-36: Symmetric Bow correction.

4. To enable a symmetric adjustment, make sure the *Symmetric* slider is set to *On*.
The slider is enabled when set to the right and when it is colored blue.
5. Select the side of the picture to be bow corrected, confirm by pressing enter, and use the arrow keys to adjust the angle and linearity (length) of the vectors.
The angle is adjusted by the up and down arrows on the remote control, and the linearity is adjusted by the left and right arrows.
The correction will occur symmetrically on each side of the center of the highlighted side.
When corrected with the values in the image above, the picture will occur as shown below.
Repeat this step for all sides of the picture that has to be corrected.

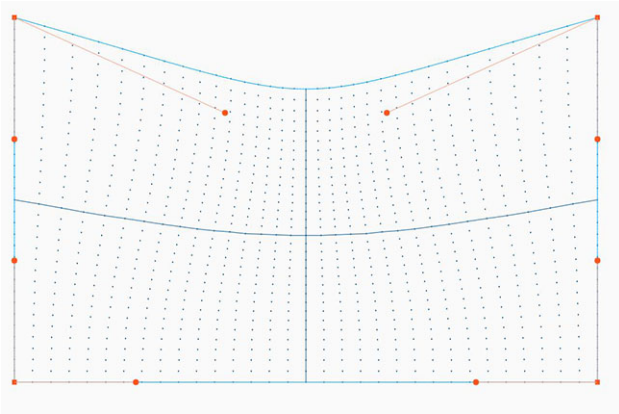

Image 8-37: Symmetric bow correction

Non symmetric bow correction

1. Enter the Bow menu, and disable the symmetric slider.
2. There are now two vectors on each side of the picture that can be adjusted individually. Select each of them, and adjust angle and linearity (length) individually to obtain the correct correction.

The angle is adjusted by the up and down arrows on the remote control, and the linearity is adjusted by the left and right arrows

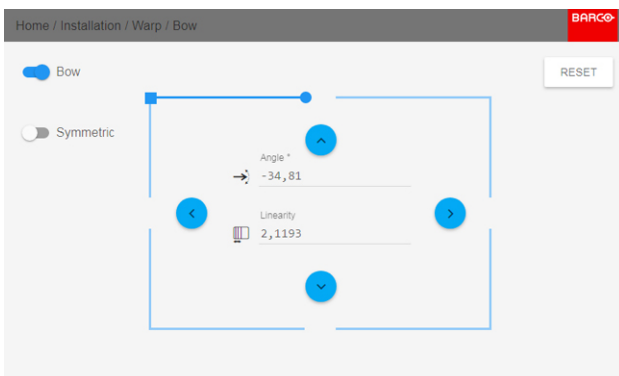

Image 8-38: Left vector of the upper side of the picture.

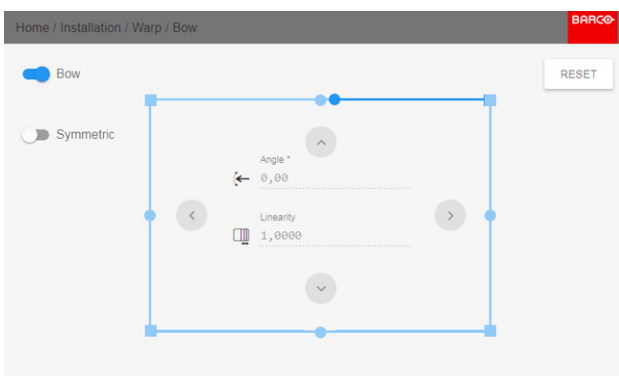

Image 8-39: Right vector of the upper side of the picture.

3. When corrected with values in the illustrations above, the picture will occur as shown below. Observe that the upper side of the picture now has an asymmetric correction.

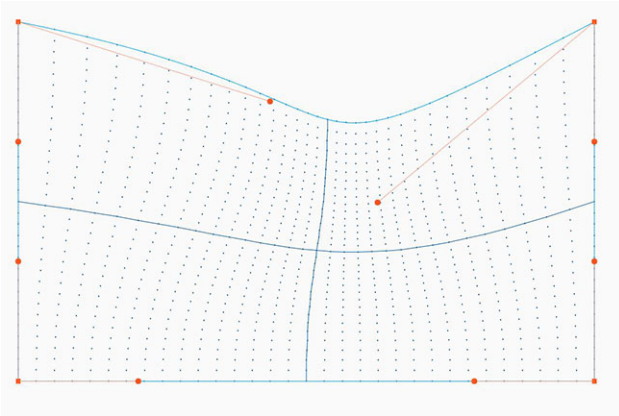

Image 8-40: Asymmetric bow correction

4. Repeat the step for each side of the picture that must be corrected.

Definition of angle and linearity (length) in the bow warp procedure

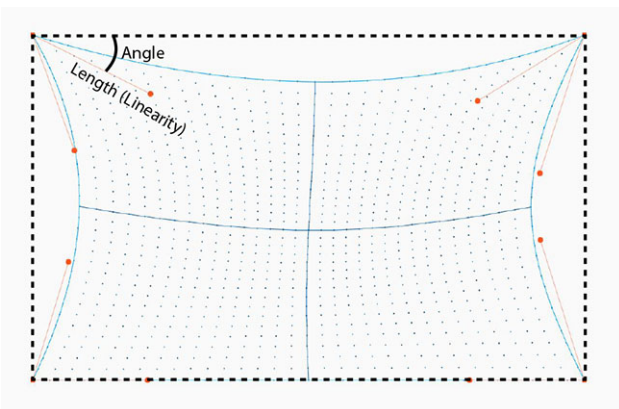

Image 8-41



To reset the bow adjustments, select *Reset* and press the **OK** button.

8.5.6 Warping – Warp files

About custom Warp Files

Next to setting your specific warp configuration in the GUI, you can also upload or download a custom warp grid in XML format to/from the projector. This is a time-saving option when multiple projectors need an identical Warp configuration.

To upload or download warp files you can use Projector Toolset or Prospector tool to upload/download the warp grid in the format of an XML file. Alternatively, you can contact the “file endpoint” directly via the curl program or some other tool that supports http upload.

For more information on uploading/downloading Warp files using the Projector Toolset, refer to the Projector Toolset user manual.

For more information on uploading/downloading Warp files using curl or other tools that supports HTTP upload, refer to the Pulse API Reference Guide.



When uploading a warp file that is too big, or with warp parameters outside the limits of the projector, some irregularities can occur. It will show up in two ways:

- 1: No warp enabled, picture still unwarped.
- 2: Distortions and artifacts in the edges of the picture.

There will be no error messages or warnings in the display when this occurs. The above mentioned symptoms is the only indication of this case.

How to activate an uploaded Warp grid?

1. In the main menu, select *Installation* → *Warp*.



Warp, Screen Size, 4 Corners, Bow, W...

Image 8-42: Installation menu, Warp

2. In the Warp menu, select *Files*.



Image 8-43: Warp menu, Files

The Warp Files menu is displayed.



Image 8-44

3. If any custom Warp files are available, select the desired warp file.



Image 8-45

4. Click on the on/off button on top to activate the selected warp file.



Image 8-46

8.5.7 Warping – Latency control in a multi projector setup

Transport latency

 The added delay in the image processing chain. The value is the number of lines relative to the output resolution.

Latency

 The total time from the first pixel is coming in on an input source, until the first light representing that pixel is visible on the screen. This includes the transport delay. The value is normally given in milliseconds.

Functional description

Every projector in a multi-projector setup will have a different latency. This latency depends on the amount of warp and on the frequency of the projected image. In order to have no visible difference in the overall projected image, the user needs to be able to control the latency of each projector.

The latency value can be read out in the status menu for each individual projector.

How to configure transport delay?

1. Read out and note the latency of each projector in the multi-projector setup. You can find this latency under **Transport delay** in the status menu for each projector.
2. Identify the projector with the longest delay.
3. For each projector in the setup, select *Installation* → *Warp* in the main menu.

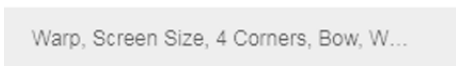

Image 8-47: Installation menu, Warp

4. In the Warp menu, select *Transport Delay*.



Image 8-48: Warp menu, Transport delay

The Transport menu is displayed.

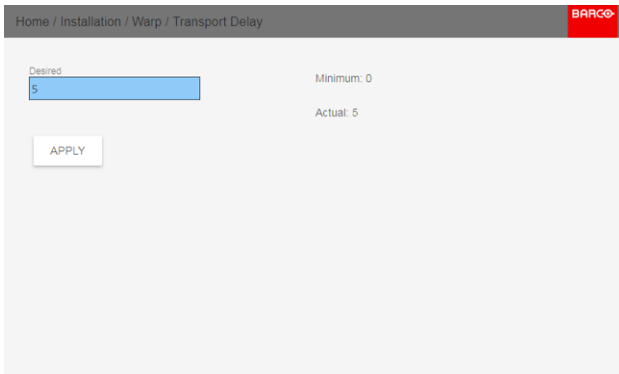

Image 8-49

5. Enter the value either by the arrow keys (one step at a time) or directly by the numeric keys on the remote control.
6. Enter “Apply” to confirm the value.
7. Repeat this process for every projector in the setup.

8.6 Blending

8.6.1 Basic blend

About

When two projectors are used together to make one picture on the screen, the blend function must be activated. This blend function ensures a seamless transition of the images between the two projectors.

The principle is that the light intensity in the blend zone from each projector will be adjusted individually, so that the rendering on the screen are perceived as from one projector.

The blend function can be enabled for both pictures over/under, and pictures side by side.

The blend will not be affected by the projector's warp.

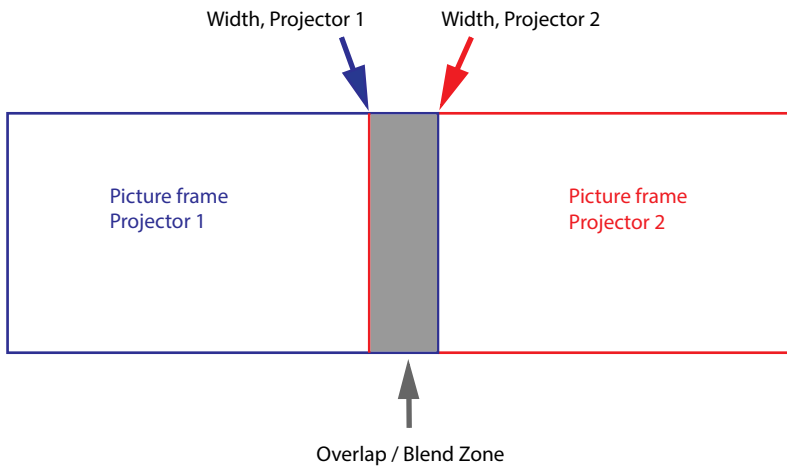

Image 8-50

The Mask adjustments.

The offset adjustments are used to cut the image on each side. Normally used to hide parts of the picture that shall not be shown on the screen. An example can be: If the source is a pc, you may want to hide the menu bar at the bottom of the screen.

8.6.2 Set up the system

How to set up the system

In this chapter, the setup procedure for the projectors is explained, but a setup procedure must also be performed for the picture source.



In order to obtain a satisfying result for the Blend function, the overlap / Blend zone are recommended to be at least 10% of the picture width.

The basic principle is that the overlap setup in the source shall correspond with the blend width setup for the projector. That means that if the overlap zone for the source is set to 500 pixels, the width of the blend zone for the projector also must be set to 500 pixels.

First step is to align the image from the projectors as accurate as possible in a mechanical way, meaning without any optical corrections. At the same time, establish an overlap in the pictures between the two screens.

Then adjust the remaining irregularities by using the shift and warp features in the projectors to obtain the last fine tuning of the alignment.

Setup the source to a blend which corresponds with the preset overlap on the screen. There are different ways to do this, depending on the source. Refer to the source unit's manual for this issue.

Adjust the Blend for the projectors as described below.

8.6.3 Adjustment procedure

Blend adjustment procedure

Entering the Blend Adjustment from the Home menu, either by the remote control, or the keypad on the projector. *Home/Installation/Blend And Mask/Blend Mask* The menu shown below appears on the OSD.

The "Enable" button enables/disables the blend function. The "Show Lines" enables alignment lines on the screen, in order to visualize the overlap/blend zone.

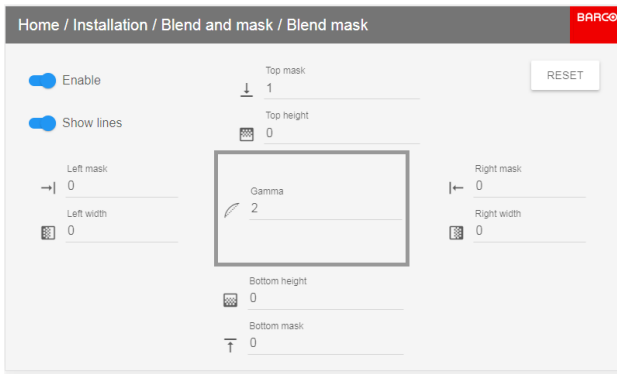

Image 8-51

Use the up/down/left/right arrow key on the remote control or key pad to navigate in the menu.

Blend adjustment procedure. Side by side configuration.

1. Starting with the left picture: By the arrow keys, place the display cursor on respectively the “Enable” zone and the “Show Lines” zone and activate them by pressing enter.
2. Use the right arrow key to move the cursor to the “Top Mask” position in the menu. Press enter. From this position the cursor can be moved around to the desired adjustment options.
3. Move the cursor to the “Right Width” position and press enter on the remote control.
4. Adjust the width value by using the arrow keys up (or down), one step at a time. By pressing the key arrow constantly, the blend value will increase rapidly. The numeric value of the width is shown on the screen next to the alignment line. (The number entered represent the blend width expressed in number of pixels). Confirm position by pressing enter.
5. For the right picture, repeat the procedure, but adjust the Left Width instead of the right width. The numeric value for the left width shall ideally be the same as for the right width for the left picture in the steps above.
6. Exit the menu by using the exit button on the remote control.

Adjustment procedure in over / under configuration.

For Blend adjustments in over / under configuration, the procedure is the same as for side by side, but use the Top and Bottom height instead, and perform a similar procedure.

Use the numeric keys instead of the arrow key to set the values.

Instead of adjusting the lines by the arrow keys, the value can also be typed directly using the numeric keys on the remote control.

To remove or undo the entered numbers, use the * key on the remote control.

8.6.4 Black level adjustment

About adjusting the black level

The Purpose of the black level adjustment is to adjust the black levels in the non overlapped areas with the black level in the overlapped areas (Blend Zone).

This is a necessary function, due to the fact that the black level will be brighter in the blend zones, since multiple projectors will add light in these zones.

The width of the black level area shall ideally be slightly larger than the width of the blend zone in order to also compensate for the “sea of mirrors” phenomenon.

The figure below shows how this occurs in a side by side configuration without any correction of the black level.

Picture Left

Blend Zone

Picture Right

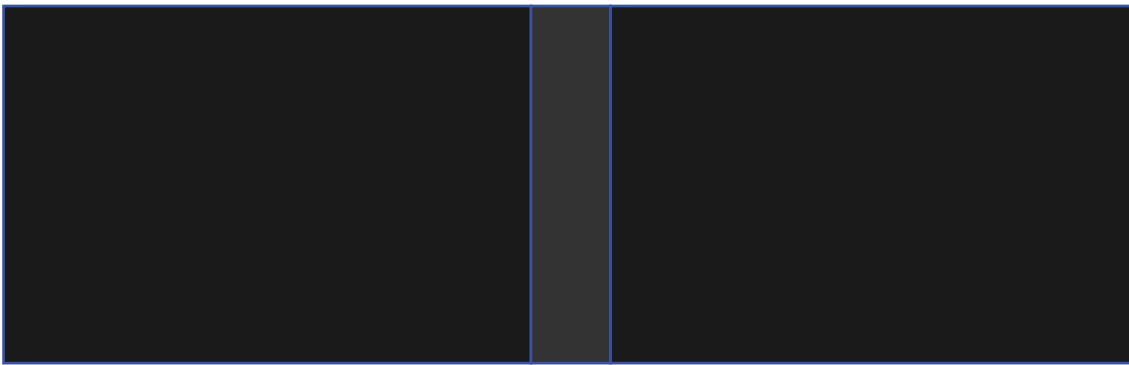

Image 8-52

How to adjust the level manually

1. In the main menu, select the Basic Black level menu

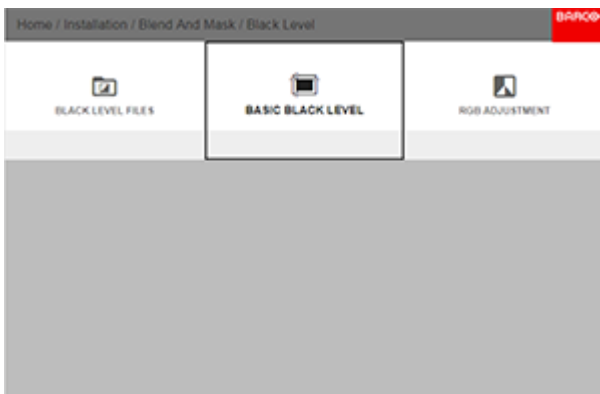

Image 8-53

2. Enable the "Black level" and "Show lines" buttons.

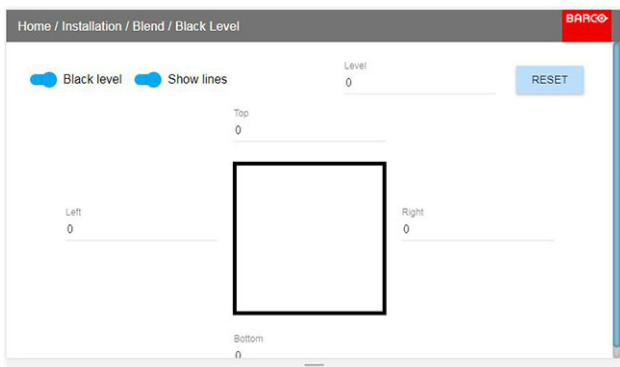

Image 8-54

3. Move the cursor to the side where the overlapped area occurs. (Left/right/top/bottom.) For the left projector, this will be the right side in the menu. Press enter, and adjust the value with the arrow keys. As mentioned earlier, the value shall be slightly larger than the blend zone offset. A line that indicates the zone will also be visible when "Show lines" is enabled. When the black level zone is optimal, press enter.

The value can also be entered by the numeric keys in the remote control.

4. Move the cursor to "Level", press enter and adjust this level until the black level equals the level in the blend zone.

This value can also be entered by the numeric keys on the remote control.

5. Repeat the same procedure for the other projector,
6. Disable the “Show lines” when the Black level adjustment is completed.

8.6.5 Black level files

About custom Black Level Files

Next to setting your specific Black Level Adjustment in the GUI, you can also upload or download a custom Black Level adjustment file in png, jpeg or tiff format to/from the projector.

To upload or download Black Level masks you can use the Prospector tool. Alternatively, you can contact the “file endpoint” directly via the curl program or some other tool that supports http upload.

For more information on uploading/downloading Black Level files using the Prospector, refer to the Prospector user manual.

For more information on uploading/downloading Black Level files using curl or other tools that supports HTTP upload, refer to the Pulse API Reference Guide.

How to activate an uploaded Black Level adjustment file?

1. In the main menu, select *Installation* → *Blend and Mask* → *Black Level* → *Black Level Files*



Image 8-55: Blend and Mask menu, Black Level Files

The Black Level Files menu is displayed.

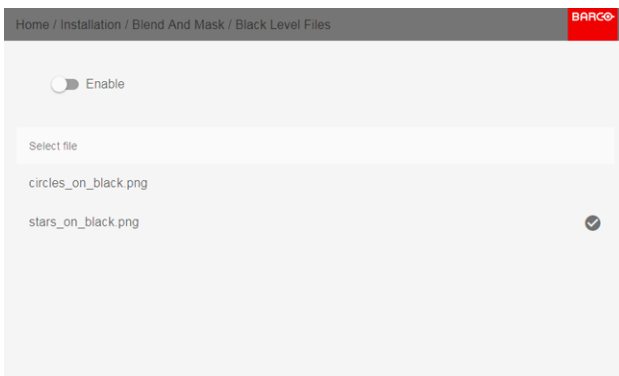

Image 8-56

2. If any custom Black Level adjustment files are available, select the desired file.

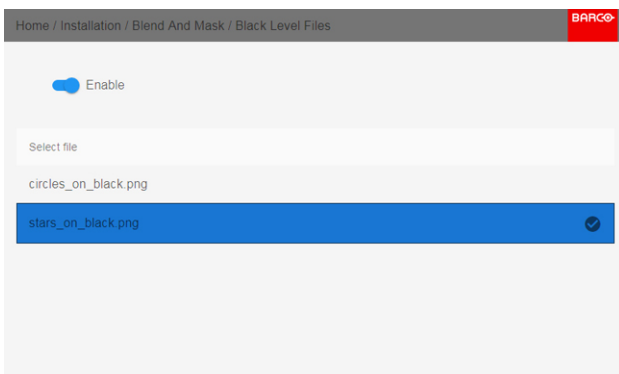

Image 8-57

- Click on the on/off button on top to activate the selected Black Level adjustment file.

8.6.6 RGB Adjustment

About RGB adjustment

The purpose of black level correction is to ensure a uniform black level in multi projector setups. Even when two projectors are of the same type, different projectors will output slightly different colors for black due to minor variations in their optical components. So if the projected image of the projectors overlap, there will be 3 different black levels: one for the zone where only the picture of the left projector (zone 1), one for the Blend zone (zone 2), and one for the zone where there is only the picture of the right projector (zone 3).



Image 8-58

The black levels for zone 1 and zone 3 are typically corrected by defining a black level mask, which is applied to the image of each projector. This system is already in place but the applied mask is monochrome.

Using the Basic Black Level menu, you can already specify the area of the mask and its contents. But by using the RGB Adjustment page, you can specify the multiplication factors (gains) for the Red, Green and Blue colors separately.

How to perform an RGB adjustment

- In the main menu, select *Installation* → *Blend and Mask* → *Black Level* → *RGB Adjustment*.

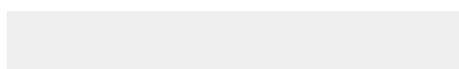

Image 8-59: Black Level menu, RGB Adjustment

The RGB Adjustment menu is displayed.



Image 8-60

2. Select one of the three sliders.
3. Use the left and right arrow keys to modify the gain of the chosen color.
4. Repeat for every slider until the desired result is achieved on screen.

8.6.7 Blend files

About custom Blend Files

Next to setting your specific Blending configuration in the GUI, you can also upload or download a custom Blend configuration file in png, jpg or tiff format to/from the projector. This is a timesaving option when multiple projectors need an identical blending configuration.

To upload or download Blend masks you can use the Prospector tool.

Alternatively, you can contact the "file endpoint" directly via the curl program or some other tool that supports http upload.

For more information on uploading/downloading Blend files using the Prospector, refer to the Prospector user manual.

For more information on uploading/downloading Blend files using curl or other tools that supports HTTP upload, refer to the Pulse API Reference Guide.

How to activate an uploaded Blend configuration file?

1. In the main menu, select *Installation* → *Blend and Mask* → *Blend Files*.

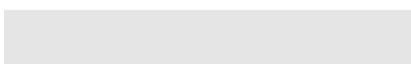

Image 8-61: Blend menu, Blend Files

The Blend Files menu is displayed.

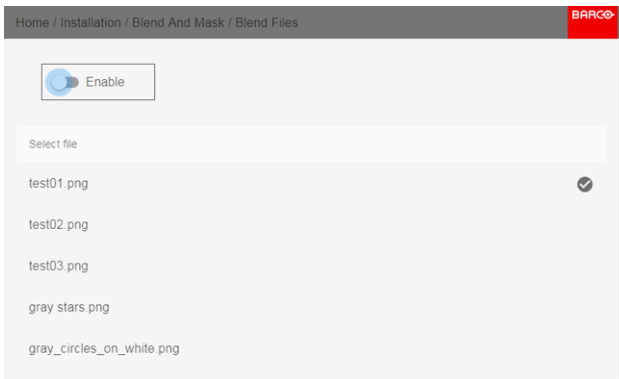

Image 8-62

2. If any custom Blend files are available, select the desired file.

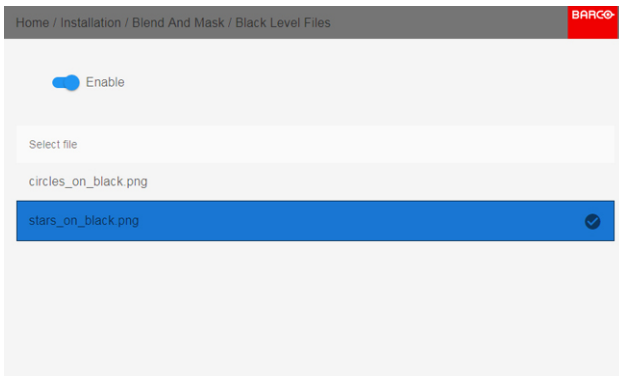

Image 8-63

3. Click on the on/off button on top to activate the selected Blend file.

8.6.8 Advanced blend

Description

The Advanced Blend Function is intended for blending in complex shapes in multiprojector installations.

Due to the complexity, a separate manual has been prepared for this subject, and can only be performed by an authorized installer. There is no user interface for this function.

8.7 Illumination

About

The LED slider is only available for the FS variant of the projector..

Home/Installation /Illumination/Power

Review light source status and adjust (dim) and adjust LED and IR power from 0 to 100%.

Default: 100%

How to reduce the output light

In the menu, select:

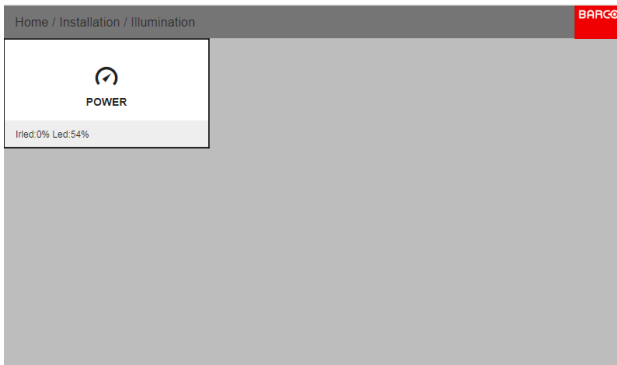

Image 8-64

The actual illumination setting is indicated in the menu. Select, and adjust the slider to desired value.

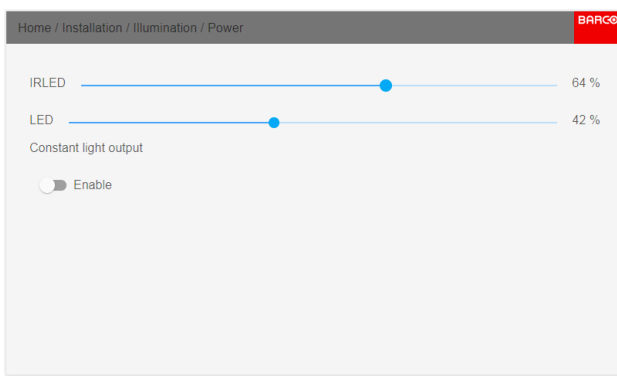

Image 8-65



When dimming the LED, a sound will occur from approximately 50% and below. This is normal.

8.8 CLO — constant light output

About

This function will ensure that the projector adjusts its illumination power to maintain the same level of output light during the lifetime of the light source. This requires that the LED power is not set to 100% from the start, but to a lower value. The lower this value is set, the longer the projector will manage to maintain the level. This is due to the fact that the light source has a naturally decreasing intensity over time.



The CLO feature is not designed to compensate the Iris adjustment. This means that if the CLO is set, and the Iris is adjusted, it will affect the output light.

Enable the CLO

Enter the menu *Home/Installation/Illumination/Power*, set the laser power slider to an appropriate value, and activate the Constant Light Output button..

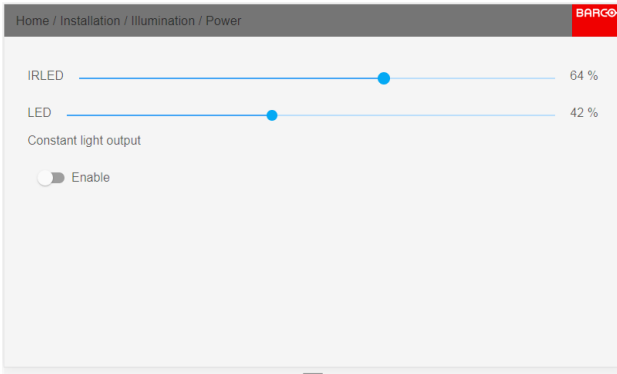

Image 8-66: Out power adjusted

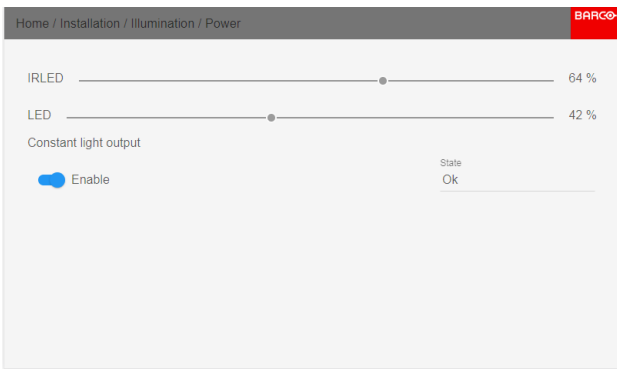

Image 8-67: CLO enabled

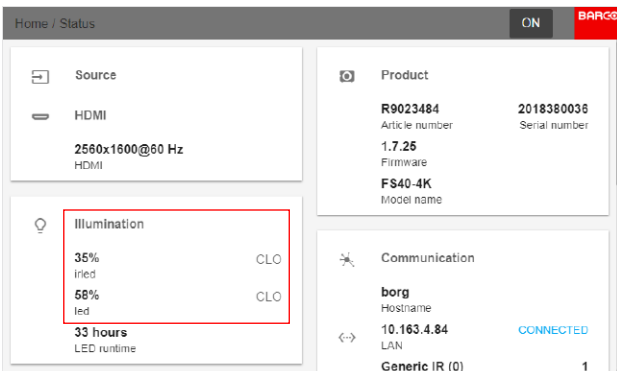

Image 8-68: Status menu information.

When the CLO is activated, this will be indicated in the status menu in both LCD and OSD.

8.9 Display setup

About

All sub-menus, except from the IG Pixel shift, are described in other topics in this manual, where they more naturally belong.

8.9.1 IG Pixel shift

General

IG pixelshift is a feature where the Image Generator can process the image in two channels.

This two input channels have different positions of the pixelshift module. Channel 1 is displayed with module position 1, and channel 2 is displayed with position 2. The result is a 4K rendering of the displayed image.

Max frequency pr channel. is 60 Hz.

Only DVI or Displayport inputs on the projector can be used for this purpose.

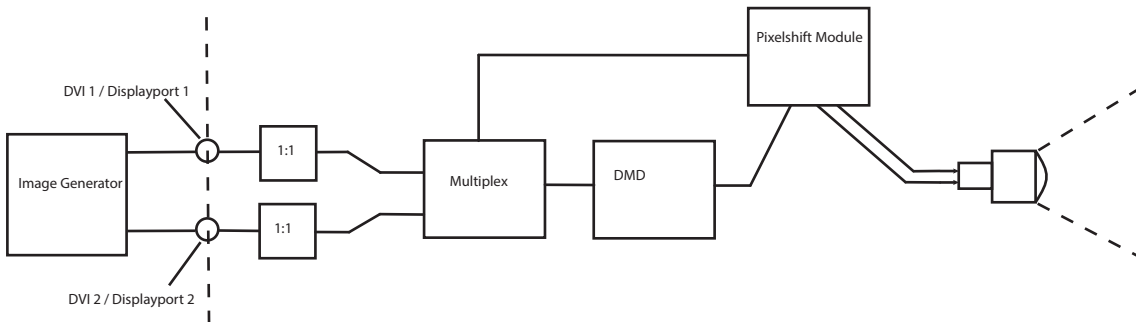

Image 8-69: IG Pixelshift. Principle of operation.

How to enable.

Perform the necessary setup of the external image source. (Image Generator).

Connect to DVI 1/2 or Displayport 1/2.

Enter the menu *Home/Installation/Display setup*

Select IG Pixelshift in the dropdown menu.



Image 8-70: Display setup Menu

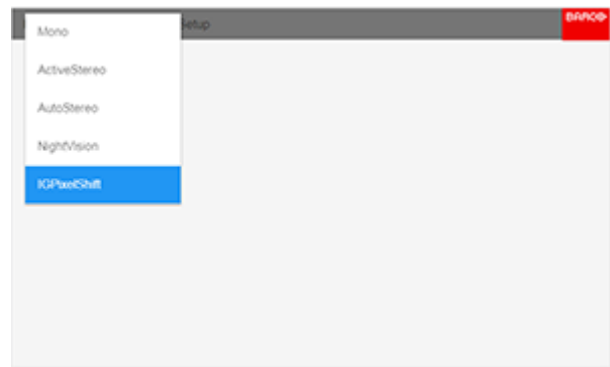

Image 8-71: Dropdown menu selection

When IG pixelshift is enabled, it will be visible in the Status Menu. (Scroll down a bit to see it), and also in the LCD Information display.



Image 8-72: Status Menu

8.9.2 AotoStereo (3D) Setup

Enabling 3D mode

See chapter "", for 3D mode setup

Profiles

9

Overview

- Profiles setup parameters
- Enable Profiles

About Profiles

The Profile function make it possible to store different profiles / projector setups for different use cases, and quickly recall them when needed. This means that there is not necessary to enter a lot of different menus to adjust the projector setup for different user cases.

As examples of different user cases are setup for video, gaming, different viewing environments and so on.

This is useful in installations where the projector are used for different purposes.

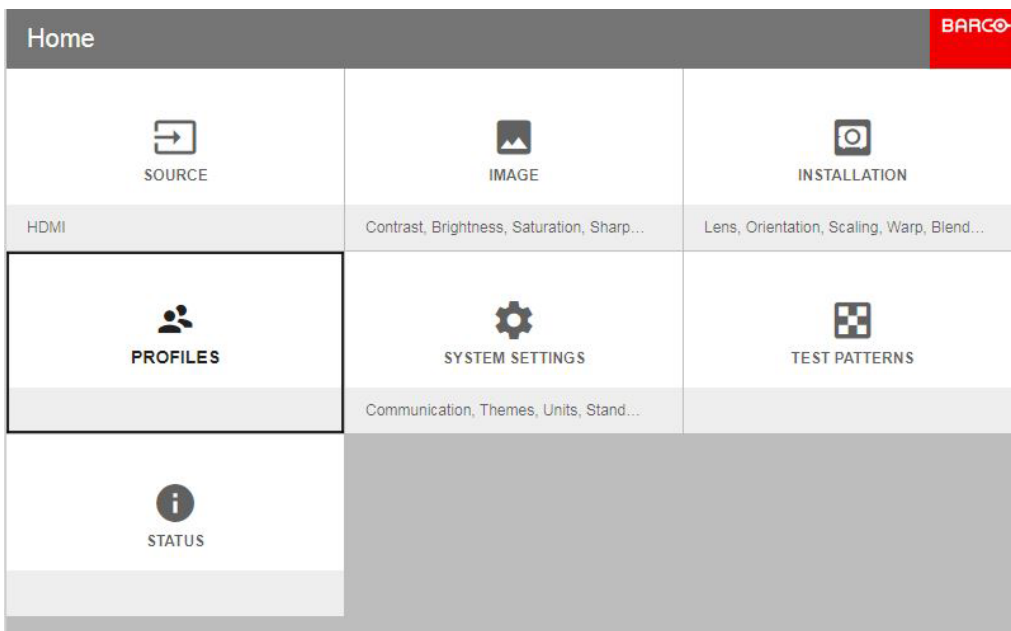

Image 9-1

9.1 Profiles setup parameters

Available profile settings

Area of interest	Settings
Source	Currently selected source
Image	<ul style="list-style-type: none"> • Brightness • Contrast • Gamma (Value and type) • Intensity • Saturation • Sharpness • Output resolution (e.g. 4K UHD, 4K UHD S or WQXGA on a WQXGA UDX) • Digital Zoom (Enabled status and factor) • Digital Shift (Enabled Status, X and Y)
PQ	<ul style="list-style-type: none"> • Screen luminance • HDR boost value
Realcolor	<ul style="list-style-type: none"> • Brilliant Color mode • P7 desired values • P7 measured values
Installation	<ul style="list-style-type: none"> • Lens parameters, if available (only valid if recalled with same lens) <ul style="list-style-type: none"> - Iris - Focus - Zoom • Lens shift (Vertical / Horizontal) • Motorized Frame parameters, if connected <ul style="list-style-type: none"> - Rotate - Tilt - Skew • Shutter position • Image orientation • Scaling mode
Warp settings	<p>Note: Only file-based warp supported via profiles</p> <ul style="list-style-type: none"> • Warp enabled status • Selected warp file • Transport delay
Blend	<ul style="list-style-type: none"> • Mask blend <ul style="list-style-type: none"> - Enabled status - Start and Width for each side • File blend <ul style="list-style-type: none"> - Enabled status - Selected files • S-curve ("gamma")
Black Level	<ul style="list-style-type: none"> • Mask Black level <ul style="list-style-type: none"> - Enabled status - Width for each side • File Black level <ul style="list-style-type: none"> - Enabled status - Selected file

Area of interest	Settings
	<ul style="list-style-type: none"> • R/G/B gain values
Illumination	<ul style="list-style-type: none"> • Illumination power for each source • CLO enabled status • CLO setpoint
Display	<ul style="list-style-type: none"> • Display mode (ActiveStereo, AutoStereo or Mono) • 3D settings <ul style="list-style-type: none"> - Dark time value - Swap Frame Pair On/Off - Sync Delay value - Sync Delay Invert On/Off

9.2 Enable Profiles

1. Adjust the necessary projector set up values for the actual user case as described in the specific topics in this manual.
2. Enter the menu *Home/Profiles/New*

When pressing OK (confirm selection (✓)), a keyboard will show up.

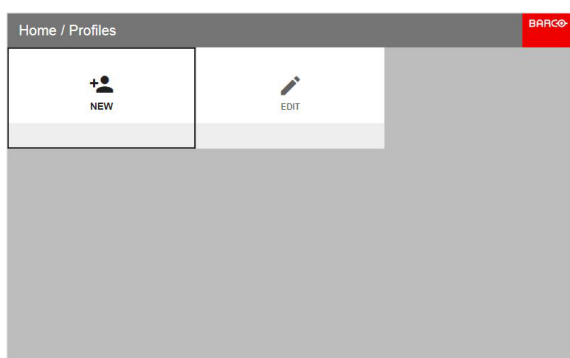

Image 9-2

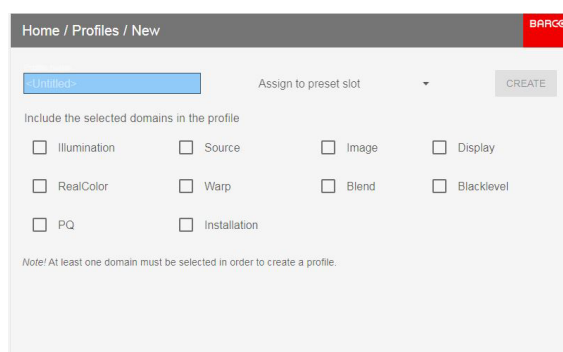

Image 9-3: Press OK

3. Enter a suitable name for this profile via the pop up keyboard (arrow keys and OK (✓) to select). End the name entry by selecting the “return” key on the pop up keyboard.

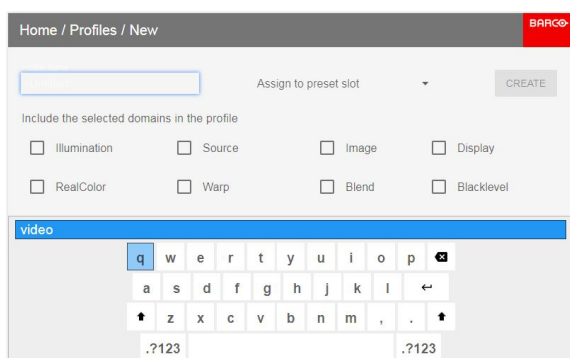

Image 9-4: Enter a name for the profile

4. Select the “Assign to preset slot”. A drop down menu will show up, select the preferred value.

Note:



The function “**Assign to preset slot**” enables a shortcut to the actual profile from the remote control. If assigned preset slot are set to 1, this profile can be recalled by pressing the key MACRO and then 01 on the remote control. It is not a requirement to use this function, just an option.

Note:



The maximum number of profile presets is 30.

5. Select the domains in the menu that shall be stored in the profile.

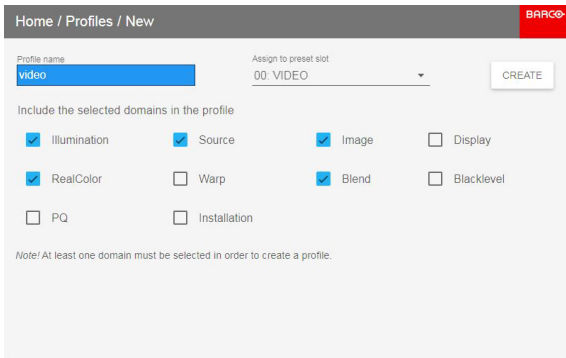

Image 9-5: Select domains

6. Select “create” and confirm by the OK button.
The profile “video” are now created and saved.
7. Repeat step 1 to 6 for creating of more profiles.

Recall a profile.

1. Enter the menu *Home / Profile*
The stored profiles will be visible in the menu. Select the actual profile.

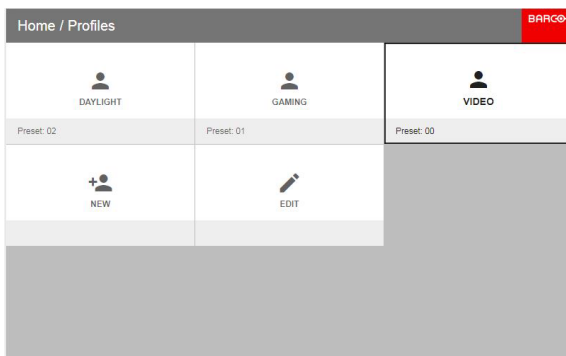

Image 9-6

OR
Select the numeric shortcut from the remote control.

Edit a profile

1. Enter the menu *Home/Profiles/Edit*
Select the profile to be edited.
2. Set, or change the “Assign to preset slot” number, or delete the actual profile. It is not possible to add or remove selected features in an stored profile. Must then be deleted, and a new profile must be created.

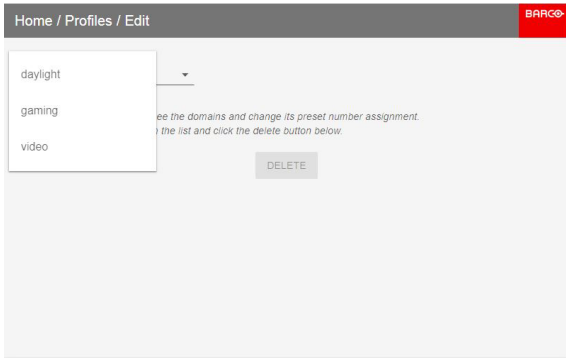

Image 9-7

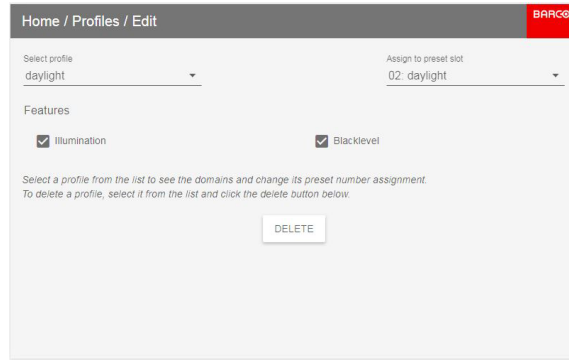

Image 9-8

System settings menu

10

Overview

- Communication
- Apply a menu theme
- Units
- Standby ECO
- Maintenance
- Reset
- Lens features
- Controlling the backlight of the LCD Display

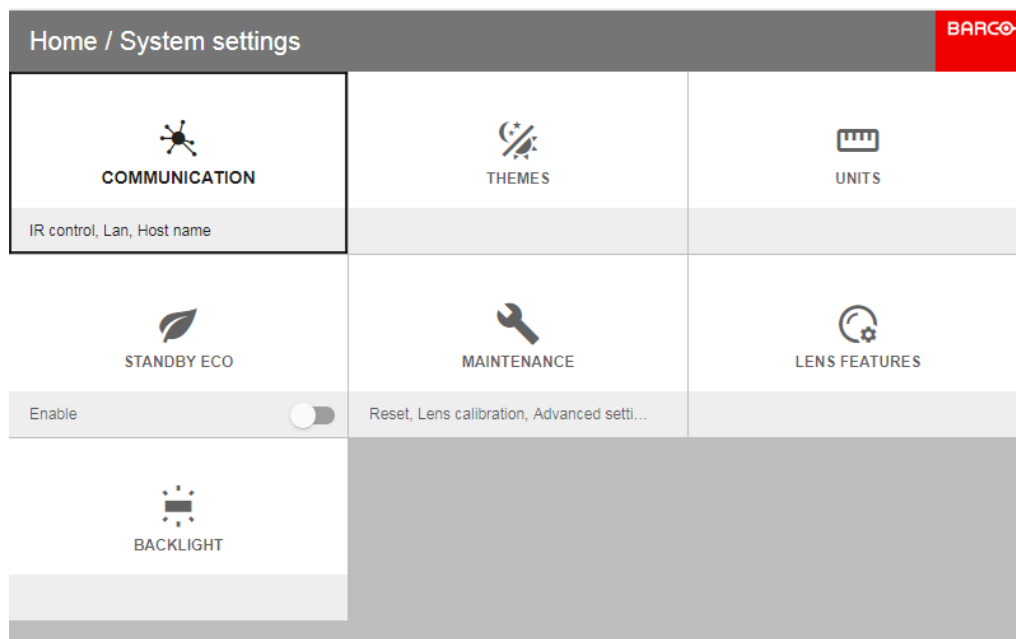

Image 10-1

10.1 Communication

About

System settings / Communication

Network connection is required to communicate with the projector via LAN or Internet.

Current Ethernet communication information is given, and can be edited in this menu.

Default mode for Ethernet communications are: Automatic ON / IP Version 4 DHCP mode.

Setting	Description
Automatic	
ON	DHCP enabled
OFF	Static
IP version 4	
Static mode	Set address, subnet mask and default gateway according to network specification.
DHCP mode	Assigned IP address, subnet mask and gateway.

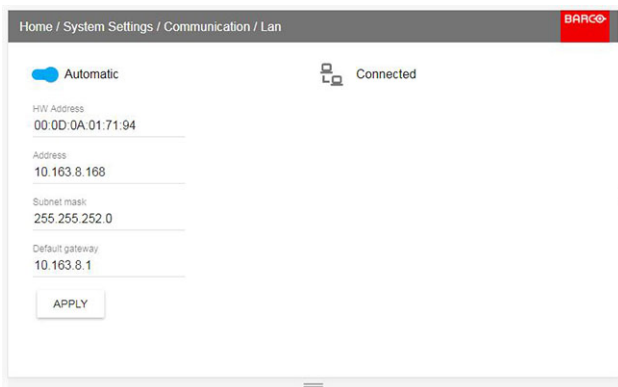

Image 10-2

Manually set up the IP address

Go to the menu *System settings / Communication / LAN*

Enable the Auto zone on the display and press enter. The Auto zone will change to “Manual”.

Scroll down, and modify the desired fields. When in the desired fields, press “Enter” to enable the virtual keyboard, enter the desired values, and press “Enter” again to confirm the change.

10.2 Apply a menu theme

About

System settings / Themes

Themes are used to apply a predefined functionality to the OSD display. There are two options: light (default) or dark. (From software version 1.5, the “Dark” theme is the default.)

It is the “Light” option that is shown in the menu screenshots in this manual, as this gives a better rendering.

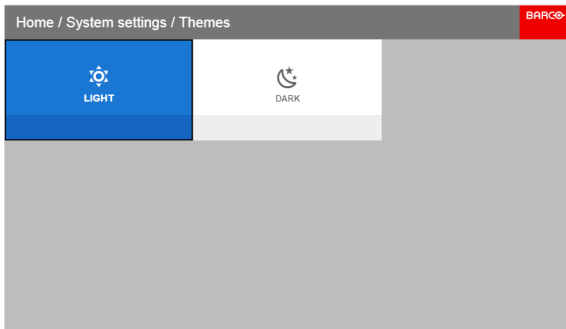

Image 10-3: Select theme, dark or light.

10.3 Units

About

System settings / Units

Units are used to set the preferred units of measurements for temperature and distance.

Enter the menu and select the preferred units.

Temperature units: Celsius (C) and Fahrenheit (F).

Distance units: Meter (M), Centimeters (C), Feet (FT) and Inches (IN)

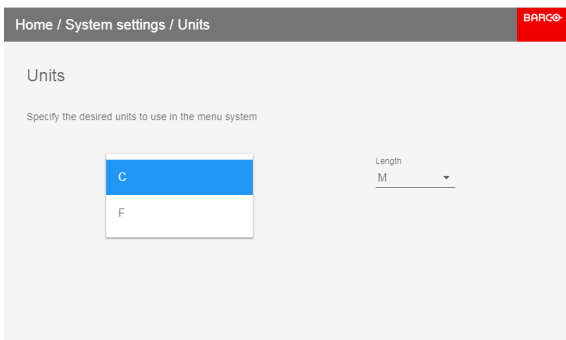

Image 10-4: Select temperature unit

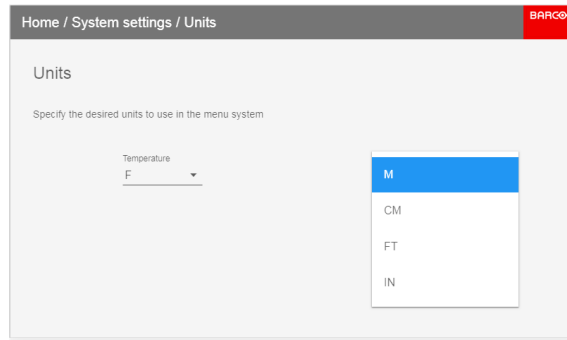

Image 10-5: Select distance unit

10.4 Standby ECO

About Standby ECO

When the ECO mode is enabled, the projector will automatically go to **ECO standby** mode after a time-out (default 15 minutes). All electronics (including fans, pumps, ...) go down except for a very small wake-up controller. See section dedicated to the Power Mode transitions for further details.



Until recently, it was not possible to navigate through the on-screen display (OSD) of the projector while in Ready mode. This feature has been implemented from software version 1.7 onward.

How to enable / disable the ECO mode

1. In the main menu, select *System Settings* → *Standby ECO*.
2. Use the arrow keys to navigate to the Standby ECO menu. Toggle the Enable / disable switch by pressing the OK button. ECO mode is enabled when the slider is set to the right and it is colored blue, and disabled when the slider is set to left and colored grey.

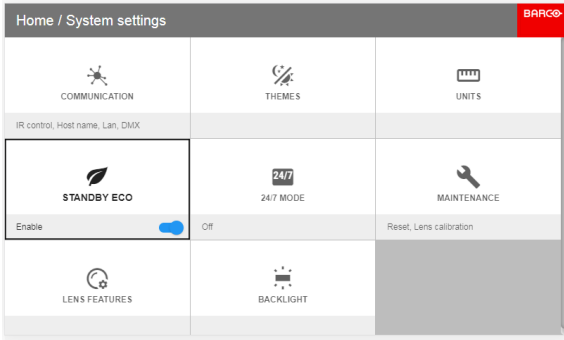

Image 10-6: ECO mode enabled

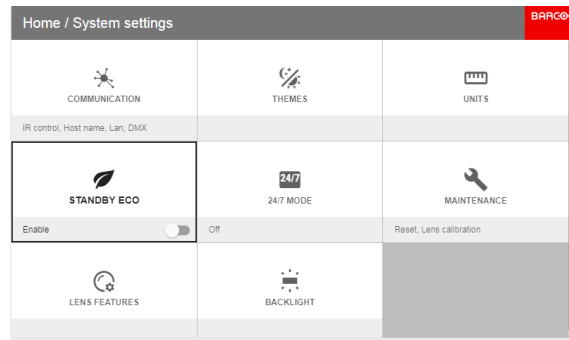

Image 10-7: ECO mode disabled

10.5 Maintenance

About

System settings / Maintenance

The Maintenance Menu is for service personnel and / or advanced users only. Sub –menus are Reset and Lens Calibration.

By entering a service code (or advanced user code), more features are available. This features will be visualized via the new tiles that shows up after entering the code.

See the Service Manual for detailed information regarding service issues.

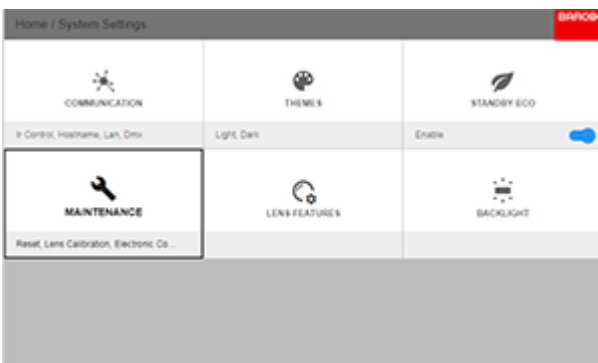

Image 10-8: Maintenance Menu

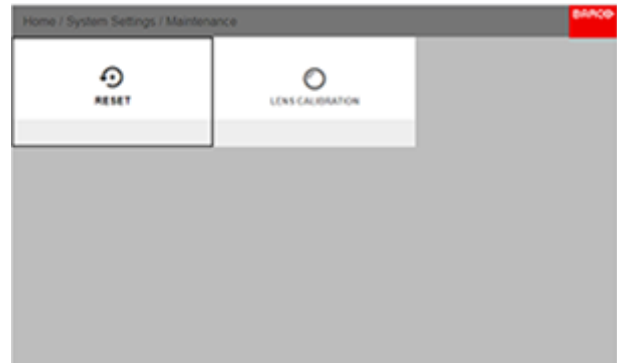

Image 10-9: Maintenance Sub-menu

10.6 Reset

What can be done?

All settings and values on the projector can be reset to its default values. This can be done for one or more settings separately, or all settings together (factory reset).

Default settings

The following settings are default settings:

Topic	Setting	Default value
UserInterface	Theme	Dark
Network	Communication	LAN, Automatic settings
System	Eco Mode (if applicable)	Available
Screen	Screen luminance - Unit	nits

Topic	Setting	Default value
Optics	High Contrast	Off
Illumination	Power	100%
ImageConnector	Color Space	auto
	Signal Range	auto
ImageResolution	Output Resolution (if applicable)	4K UHD
ImageWarp	Screen size	5120x3200 / 2560x1600
	4 corner Bow	Warp off, no warp
	Warp files	Disabled, no files selected
ImageBlend	Blend/Mask size Black Level	disabled, all value to zero
	Black Level Files Blend Files	Disabled, no files selected
ImageRealColor	P7 Realcolor	all set to native
ImageStereo	Sync delay	0 μ s
	Swap eye	Off
	Dark time	lowest value available
ImageDisplay	Display mode	AutoStereo
ImageOrientation	Orientation	Table, Front
ImageSource	Source files	Standard
ImageFeatures	Contrast	mid value
	Brightness	mid value
	Saturation	mid value
	Sharpness	mid value
	Gamma	mid value
	Cropping (if applicable)	Off
	Aspect Ratio (if applicable)	16:9

How to reset all projector settings

1. In the main menu, select *System Settings* → *Reset*.
2. In the Reset menu, select *RESET ALL* and click **OK**.

How to reset one or more projector settings

1. In the main menu, select *System Settings* → *Reset*.
The Reset menu is displayed.

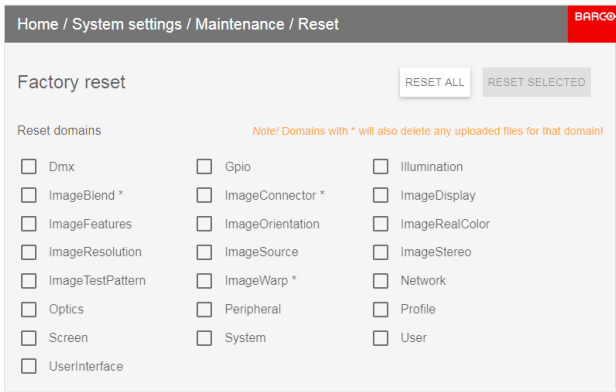

Image 10-10: Reset menu

2. Navigate to the checkbox next to the settings that need to be reset and press **OK**. Multiple selections are possible.
3. Select **RESET** and press **OK** to reset all selected settings.



Domains with * will also delete any uploaded files for that domain.

10.7 Lens features

About

In order to prevent unintentional lens adjustments, especially after e.g. a completed setup and adjustment, there is a possibility to disable certain lens adjustment functions. These functions are directly accessible via the remote control, and can by that easily be adjusted by accident.

Enter the menu shown below, and disable the desired functions by toggling the desired buttons. The menu below shows all lens options in enabled position.

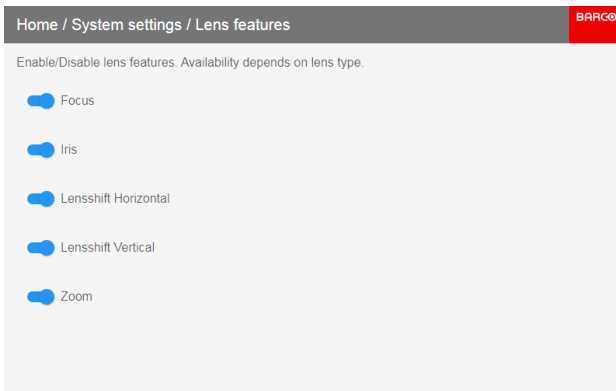

Image 10-11

10.8 Controlling the backlight of the LCD Display

What lighting can be controlled?

You can choose how quickly the backlight of the LCD turns off. You can select one of the default values, or enter a custom value.

Stealth Mode

Alternatively, you can turn on **Stealth Mode** instead. By activating this mode, the backlight of the LCD, the backlight of all the buttons of the keypad and the indication LEDs for the LAN and HDBaseT inputs will be disabled

Stealth Mode is enabled and disabled by pressing the OSD button on the remote control for 3 seconds.

How to set the backlight

1. In the main menu, *System Settings* → *Backlight*.

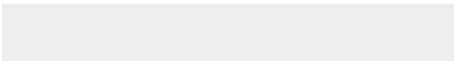

Image 10-12: System settings, Backlight

The Backlight menu will be displayed.

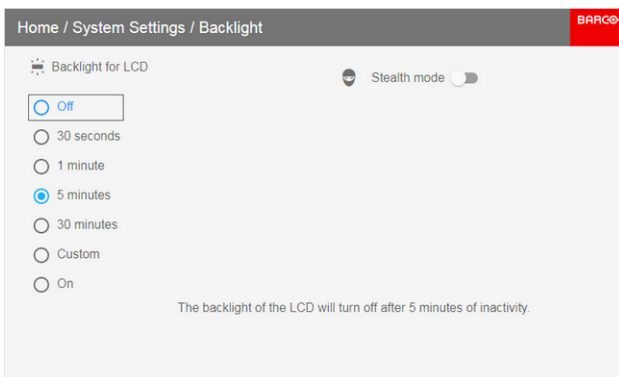

Image 10-13: Backlight menu

2. Choose the desired setting for the backlights. Select one of the predetermined options, or a custom value.

Status menu

11



This is a status menu only. No changes can be made to settings from this menu.

Overview

- Status menu overview

11.1 Status menu overview

Status menu

While in the main menu, press Status.

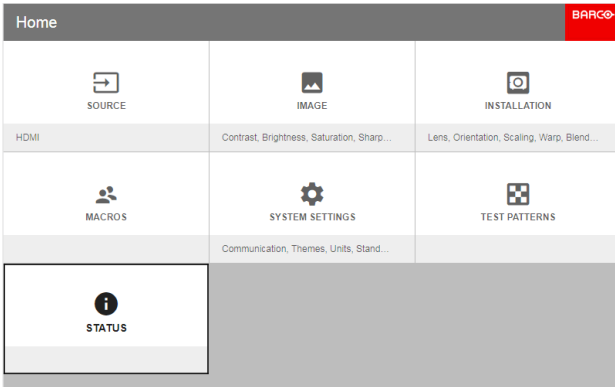

Image 11-1: status Menu enter

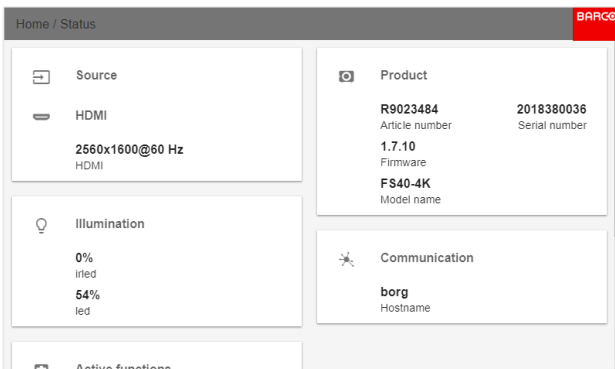

Image 11-2

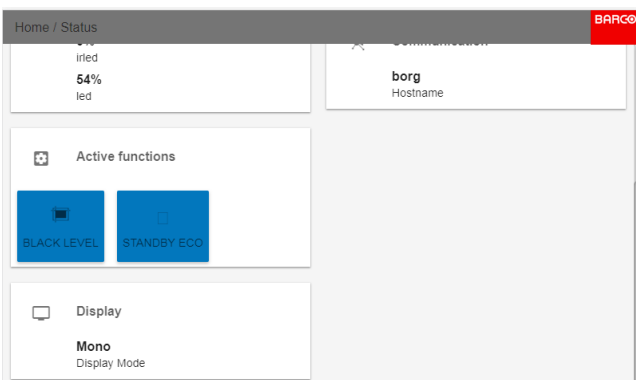

Image 11-3

Source status

Displays active source information

Product

Displays active product information:

- Article number: Projector article / part number
- Serial number: Projector serial number
- Firmware: Projector software package version

- Model name: Projector model name

Illumination

Shows the used light source power (in %) and runtime.

Communication

Lists the projector network address, the remote control broadcast address and the remote control projector address.

Warp

Displays the Warp status and type of warp used

Blend

Displays the Warp status and type of Blend used

Environment

Shows the ambient temperature.

Display

Shows display settings

Active Functions

Shows the active function enabled.

3D setup

The projector is capable of displaying 3D images and movies in both active and passive stereo 3D input mode. Setup of a 3D installation requires an advanced understanding of the 3D systems, both for the projector, and also for the signal source.

Regarding setup of the signal source, refer to the user manual for the specific unit.

In 3D setup, it is crucial that the projected images are perfectly synchronized through the whole signal path, from the signal source to the picture viewed through the 3D goggles.

See instructions in this chapter to set up the projector for this feature.

Active stereo input.

One channel input. (One cable). Update frequency @ 120 Hz. Extra sync. signal must be used when DVI source is used. For Displayport source, the sync signal is present in the signalcable, but external sync can also be used when necessary.

Passive stereo input.

Use two channel input (two cables), one for each eye. Update frequency limited to 60 Hz for each channel. Dual Sequential input source (DVI or Displayport) must be used. No external sync signal required.

Overview

- Setup 3D mode.

12.1 Setup 3D mode.

Setup 3D mode.

1. Enter the Source menu, and select the desired input source.
 - For active stereo input, select Displayport 1, DVI-1, HD BaseT or HDMI.
 - For passive stereo input, select Dual displayport sequential, or Dual DVI sequential

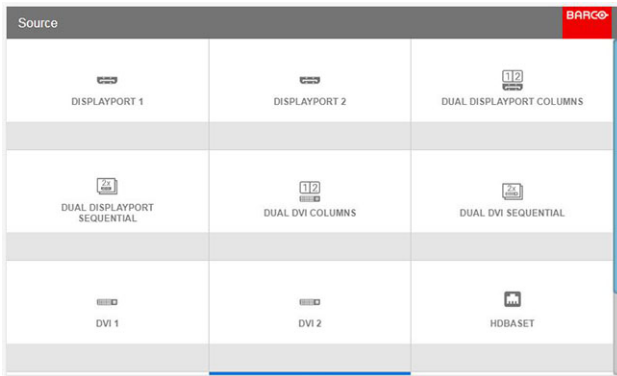

Image 12-1

2. Enter the menu *Home/Installation/Display Setup*, and select AutoStereo in the drop down menu. (The other choices in the drop down menu is not applicable).

When in 'auto stereo' display mode, the product shall automatically switch to 'active stereo' mode and project synchronously at n times the input frequency - where n is as high as possible on the individual products.



Image 12-2

3. When a HDMI 3D source is detected, it is shown in the source status that this is a 3D source.

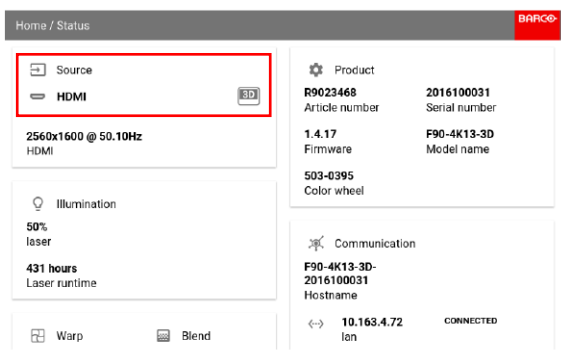

Image 12-3

4. Enter the menu *Home/Installation/3D Setup*, and select the dark time.

5. Run a 3D image or movie from the source.

Put on the 3D goggles, and verify by looking through the goggles with one eye at the time that only one image is visible in each eye. A double picture or a shade of the picture from the other side shall not be observed. Repeat for both sides, and adjust the Sync Delay slider until a “clean” picture is visible in each eye.

If the 3D picture looks a bit “strange” through the 3D goggles, the solution is to swap eyes by enabling the Swap eyes button in the menu.



Note: There is also a 3D test pattern available. Go to the menu *Home/Test Patterns/Internal* Select the 3DSTEREO pattern.

The test pattern menu also have a shortcut key on the remote control and the keypad.

Why change the 3D setup?

While Barco can provide a 3D emitter and active shutter glasses as options to this projector, you are also free to use a 3D emitter and active shutter glasses of your own choice. Since glasses and emitter can have various specifications compared to the ones Barco can provide, the 3D setup menu allows you to configure the output image to the specifications of your glasses and emitter. The following can be configured:

- **Swap Eye:** You can choose to invert the stereo Sync output signal (depending on the chosen 3D emitter and glasses).
- **Swap frame pair:** You can choose to invert the stereo input signal (depending on the chosen source input).
- **Dark time:** Pre defined, select between 0 μ S and 1600 μ S.
- **Stereo glasses:** Active 3D glasses must be used.
- **Sync Delay:** You can increase or decrease the sync delay. The scale goes from -10 000 μ s to +10 000 μ s with a step of 100 μ s.



Image 12-4

Upgrade projector firmware

13

Overview

- Upgrade procedure

13.1 Upgrade procedure



CAUTION: Do NOT power down or remove mains power supply when an upgrade is in progress.



Once initiated, the upgrade procedure can take up to 20 minutes to complete. The LCD display will show the progression and status of the upgrade during the process.

Update

- Go to www.barco.com and select your product. All available firmware downloads are filed under the Technical Downloads tab.
- Download the firmware. Extract and save the file to a USB stick with FAT file system. Use the eject function on your PC to safely remove the device from the computer.
- Place the projector in Ready mode (status indicator is steady White).
- Insert the USB Stick in to the rear USB port on the projector.
After a few seconds, the status indicator will flash. (rate: 3 Hz/180 FPM). This signals that the upgrade is in progress. If the upgrade file is corrupt or invalid, the status indicator will turn red and the upgrade process will stop. Note! The upgrade will not be installed in this instance, and the upgrade process must be restarted with a full and correct file. The projector may restart several times during the upgrade process
- The LCD display will show the progress of the update procedure, and also when the USB stick can be removed. The projector will return to standby mode (status indicator is steady amber) once the upgrade is completed successfully.

User maintenance — Cleaning the projector

14

Overview

- Projector lenses
- Projector cabinet
- Filters

14.1 Projector lenses

General guidelines for cleaning projector lenses

Blow off dust with clean compressed air (or pressurized air cans) .

Use lens cleaner and a clean lens cleaning cloth to remove the dust and contamination.

Wipe in broad strokes, in one direction only.

Warning: Do not wipe back and forwards across the lens surface as this tends to grind dirt into the coating.

Use a dry clean lens cleaning cloth to remove left liquid or stripes. Polish with small circles.

If there are still fingerprints on the surface, repeat with lens cleaner and a clean lens cleaning cloth, then polish again with a dry cloth.



If smears occur when cleaning lenses, replace the cloth. Smears are the first indication of a dirty cloth.

14.2 Projector cabinet



WARNING: Always disconnect the projector from the mains power net before attempting to clean the projector cabinet.

General guidelines for cleaning the projector cabinet (exterior only)

Clean the housing of the projector with a damp cloth. Stubborn stains may be removed with a cloth lightly dampened with a mild detergent solution.

14.3 Filters

General info

This equipment is intended to operate in a “normal” environment, without any exposure to extreme amounts of dust or moisture. and by that also shipped without any kind filters for the air intake.

There are filters for extreme environments available, contact your dealer for more info.

Index

Numbers/Symbols

3D 109, 129
4K 76

A

About warping 89
Adjust
 focus 82
 iris 82
 zoom 82
Adjustment procedure 100
Advanced blend 106
Advanced image adjustments 73
Alignment
 Warping
 Bow 93
 Files 96
 Latency Control 98
 On/Off 89
 Screen size 90
Approved lenses 32
autostereo 109

B

Backlight
 Control 122
 LCD Display 122
Basic blend 99
Black level adjustment 101
Blend 99
Blending
 Black level adjustment
 Files 103
 Black Level Files 103
 Blend files 105
Bore sight adjustment 47
Brightness 67
Brilliant color 76

C

China RoHS compliance 17

Clean
 lenses 136
cleaning 136
Cleaning
 cabinet 136
 chassis 136
 exterior 136
 lenses 135
 projector 135
CLO — constant light output 107
Communication 118
Connections 52
 making 51
Connector 52
 specifications 52
Connector panel 30
Connector selection 60
Connector settings 60
Contrast 67
Control Interfaces 54
Controlling the projector 29

D

DICOM
 DICOM Gamma 69
Digital Shift 72
Digital Zoom 71
Digital Zoom Shift 70
Display setup 108
Displaying HDR content— Perceptual Quantizer (PQ) 77
Disposal Information 16

E

Edit the RealColor presets. 74
Enable / Disable Remote Control 28
Enable profiles 113

F

Filters 136
Focus
 adjust 82

Function

- RGB button 28
- RGB filter 28

G

- Gamma 68
- Gamma types 69
- General Considerations 12
- Getting started
 - Projector address 29
 - Terminology overview 27

H

- HDBaseT 53
- HDMI 53
- HDR Status. 77

I

- IG Pixel shift 108
- Illumination 106
- Image 99
 - brightness 67
 - contrast 67
 - saturation 67
- Image menu 65
- Important safety instructions 12
- Importer 19
- Inspection
 - Initial 39
- Installation
 - positioning 39
- Installation conditions 38
- Installation menu 79
- Installation process 38
- IR / Night vision functionality 80
- Iris 84
 - adjust 82

K

- keypad 24

L

- LAN/Ethernet 54
- LCD 23
- LCD functionality in Ready Mode 24
- LCD Panel 23
- Lens 82
 - Scheimpflug 46
- Lens features 122
- Lens lock 34
- Lenses 31
- local
 - keypad 24
- Location of labels 16
- Location of the main exterior components. 22
- Lock the lens 34

M

- Measurement units 119
- Mounting surfaces 41
- Mounting the projector, general considerations 40

N

- Nightvision 78

O

- On Screen Display 58
- Orientation 85
- OSD 58
- OSD Menu Mode. 24
- Output resolution 76

P

- P7 Realcolor 73
- Physical installation 37
- Positioning the projector 39
- Power
 - down 51
 - modes 51, 57
 - up 51
- Power down 55
- Power mode transitions 55
 - General 55
 - Going from ECO to ON 57
 - Going from ON to READY 56
 - Going from READY to ECO standby 57
 - Going from READY to ON 56
 - Plugging power cord 56
 - Power on projector 56
- Power on 55
- Power on button 23
- Power up 55
- Predefined Gamma types 69
- Product Info 19
- Production Address 19
- Profile setup matrix
 - Profile 112
- Profiles
 - Preset variables 111
- Projector
 - Accessories 21
 - cleaning 135
 - Consumables 21
 - Low Frequency Maintenance 21
 - Main Components 21
 - power down 51
 - power modes 51
 - power up 51
- Projector address 29
 - Controlling 29
- Projector safe attachment points 41
- Projector source and control connections 52

R

- RCU 25
 - Battery
 - Installation 25
 - Functionality overview 27
 - Protocol setup 26
- RCU on/off 28
- Removal of the front cover 43
- Replace a lens 32
- Reset
 - All 120
 - Features 120
 - Image 120
 - Motor 120
 - Optics 120
 - Orientation 120
 - Other 120
 - User Interface 120
 - Warping 120
- RGB Adjustment 104
- RS-232 54

S

- Safety and Environmental Information 11
- Safety Symbols FL40 15
- Saturation 67
- Scaling modes 86
- Scheimpflug 46
 - Adjustment points 47
- Scheimpflug adjustment 47
- Scheimpflug's law 46
- Service 120
- Service and maintenance 23
- Set up the system 100
- Settings
 - customize 57
- Setup 3D mode. 130
- Sharpness 68
- Shift 83
- Shift to center 83
- Shortcut keys 51
- Signals 52
- Smear reduction 76
- Source menu 59
- Specifications 52
- Start up 51
- Statement 20
- Status menu 125
 - Overview 126
- Stealth mode 122
- Swap channels 78
- System settings
 - menu theme 118
- System Settings
 - ECO Mode 119
 - Reset 120
- System settings menu 117

T

- Taiwan RoHS compliance 18
- Throw distance 43
- Turkey RoHS compliance 16

U

- Upgrade procedure 134
- Upgrade projector firmware 133
- USB-A 54
- User interface 57
- Using dual inputs 62

W

- Wake On LAN (WOL) 57
- Warp 89
- Warp – 4 Corners adjustment 92
- Wired RC connection 29

Z

- Zoom
 - adjust 82
- Zoom / Focus 82

