

CP42LH

User Manual

020-101363-03

NOTICES

COPYRIGHT AND TRADEMARKS

Copyright © 2016 Christie Digital Systems USA Inc. All rights reserved.

All brand names and product names are trademarks, registered trademarks or trade names of their respective holders.

GENERAL

Every effort has been made to ensure accuracy, however in some cases changes in the products or availability could occur which may not be reflected in this document. Christie reserves the right to make changes to specifications at any time without notice. Performance specifications are typical, but may vary depending on conditions beyond Christie's control such as maintenance of the product in proper working conditions. Performance specifications are based on information available at the time of printing. Christie makes no warranty of any kind with regard to this material, including, but not limited to, implied warranties of fitness for a particular purpose. Christie will not be liable for errors contained herein or for incidental or consequential damages in connection with the performance or use of this material. Canadian manufacturing facility is ISO 9001 and 14001 certified.

WARRANTY

Products are warranted under Christie's standard limited warranty, the complete details of which are available by contacting your Christie dealer or Christie. In addition to the other limitations that may be specified in Christie's standard limited warranty and, to the extent relevant or applicable to your product, the warranty does not cover:

- a. Problems or damage occurring during shipment, in either direction.
- b. Projector lamps (See Christie's separate lamp program policy).
- c. Problems or damage caused by use of a projector lamp beyond the recommended lamp life, or use of a lamp other than a Christie lamp supplied by Christie or an authorized distributor of Christie lamps.
- d. Problems or damage caused by combination of a product with non-Christie equipment, such as distribution systems, cameras, DVD players, etc., or use of a product with any non-Christie interface device.
- e. Problems or damage caused by the use of any lamp, replacement part or component purchased or obtained from an unauthorized distributor of Christie lamps, replacement parts or components including, without limitation, any distributor offering Christie lamps, replacement parts or components through the internet (confirmation of authorized distributors may be obtained from Christie).
- f. Problems or damage caused by misuse, improper power source, accident, fire, flood, lightening, earthquake or other natural disaster.
- g. Problems or damage caused by improper installation/alignment, or by equipment modification, if by other than Christie service personnel or a Christie authorized repair service provider.
- h. Problems or damage caused by use of a product on a motion platform or other movable device where such product has not been designed, modified or approved by Christie for such use.
- i. Problems or damage caused by use of a projector in the presence of an oil-based fog machine or laser-based lighting that is unrelated to the projector.
- j. For LCD projectors, the warranty period specified in the warranty applies only where the LCD projector is in "normal use" which means the LCD projector is not used more than 8 hours a day, 5 days a week.
- k. Except where the product is designed for outdoor use, problems or damage caused by use of the product outdoors unless such product is protected from precipitation or other adverse weather or environmental conditions and the ambient temperature is within the recommended ambient temperature set forth in the specifications for such product.
- l. Image retention on LCD flat panels.
- m. Defects caused by normal wear and tear or otherwise due to normal aging of a product.

The warranty does not apply to any product where the serial number has been removed or obliterated. The warranty also does not apply to any product sold by a reseller to an end user outside of the country where the reseller is located unless (i) Christie has an office in the country where the end user is located or (ii) the required international warranty fee has been paid.

The warranty does not obligate Christie to provide any on site warranty service at the product site location.

PREVENTATIVE MAINTENANCE

Preventative maintenance is an important part of the continued and proper operation of your product. Please see the Maintenance section for specific maintenance items as they relate to your product. Failure to perform maintenance as required, and in accordance with the maintenance schedule specified by Christie, will void the warranty.

REGULATORY

The product has been tested and found to comply with the limits for a Class A digital device, pursuant to Part 15 of the FCC Rules. These limits are designed to provide reasonable protection against harmful interference when the product is operated in a commercial environment. The product generates, uses, and can radiate radio frequency energy and, if not installed and used in accordance with the instruction manual, may cause harmful interference to radio communications. Operation of the product in a residential area is likely to cause harmful interference in which case the user will be required to correct the interference at the user's own expense.

CAN ICES-3 (A) / NMB-3 (A)

이 기기는 업무용 (A 급) 으로 전자파적합등록을 한 기기이오니 판매자 또는 사용자는 이점을 주의하시기 바라며, 가정 외의 지역에서 사용하는 것을 목적으로 합니다.

Environmental

The product is designed and manufactured with high-quality materials and components that can be recycled and reused. **This symbol**  means that electrical and electronic equipment, at their end-of-life, should be disposed of separately from regular waste. Please dispose of the product appropriately and according to local regulations. In the European Union, there are separate collection systems for used electrical and electronic products. Please help us to conserve the environment we live in!

Table of Contents

Introduction	9
General safety precautions	10
AC power precautions	10
Christie Laser Projection System components	11
Laser Safety Precautions	13
Laser module laser safety labels	14
LM Rack laser safety labels	16
Projector laser safety labels	17
Laser module status lights	20
LM Rack safety features	21
Projector safety features	22
Nominal ocular hazard distance	23
Operate the Projector and Run Diagnostics	25
The Touch Panel Controller	25
The Main screen	26
Turn the system on	27
Test the interlocks	27
Test the key switch	27
Test the Laser Rack emergency stop	28
Test the projector emergency stop	28
Log on to the projector	28
Laser emission indicator lights	28
View the status of projector components	29
Respond to alarms	30
Run the projector interrogator	30
View SMPTE errors	31
Clear SMPTE errors	31
Retrieve system logs	31
Run a server test	31
Turn the projector off	31
Turn the system off in an emergency	32
Manage the DLP	33
Run a DLP self test	33
Download an ICP certificate	33
Disable the ICP signature test	33

Work with Channels	34
Create a new channel	34
Activate a channel	36
Restore default channel settings	36
Change the channel icon	37
Add or remove preferred channels from the Preferred Channels pane	37
Manage Projector Setting Files	38
Create a source file	38
Modify a source file	38
Create a screen file	39
Modify a screen file	39
Create a MCGD file	39
Modify a MCGD file	40
Create a TCGD file	40
Modify a TCGD file	40
Create a new ILS file	41
Edit an existing ILS file	41
Enable automatic ILS adjustment on a channel	41
Reset ILS file settings	43
Add a lens serial number	43
Enable automatic ILS on a lens	43
Reset the lens position on projector startup	43
Complete a full lens calibration	43
Reset the ILS and the lens position	44
Work with the Scheduler	45
Schedule the projector to turn on or off	45
Edit a scheduled event	45
Delete a scheduled event	46
Delete all scheduled events	46
Turn the scheduler off	46
View and Modify Projector Settings	47
Set projector and TPC preferences	47
Adjust projector time settings	47
Modify projector communication settings	48
Add a network device	48
Access a network device	49

View the Microsoft Windows Task Manager	49
View the Microsoft Windows Computer Management console	49
View Microsoft Windows Explorer	49
View the Microsoft Network Connections window	50
View projector information	50
Record the lens serial number	50
Manage User Accounts	51
User access permissions	51
Add a user account	51
Change a user account password or permissions	52
Delete a user account	52
Backup, Restore, and Upgrade Projector Files	53
Add an upgrade file	53
Remove an upgrade file	53
Install an upgrade	53
Back up projector settings and information	54
Restore a file	54
Restore factory default settings	54
Move files to the projector	55
Delete projector files	55
Work with Test Patterns	56
Add or remove test patterns from the preferred test patterns pane	56
Turn a test pattern on or off	56
Display a full screen test pattern	56
Add Devices	57
Play unencrypted content	57
Play encrypted content	57
Connect devices to the projector	57
Projector connections and status LEDs	58
Connect the projector to a computer	60
Connect devices to the GPIO port	60
Connect devices to the SCCI port	61
Connect devices to the 3D terminal	62
View 3D Content	63
Hardware and software requirements	63

- Set up projectors for 3D 64
 - Active stereo 3D configuration 64
 - Passive stereo 3D configuration 65
 - 3D system timing 65
 - 3D input video configurations 66
- 3D sync terminal PIN map 66
 - Hardware setup 67
- Maintenance 68**
 - Shut down for maintenance 68
 - Check the coolant level 68
 - Inspect and clean optics 69
 - Remove dust from the projection lens 69
 - Remove fingerprints, smudges, or oil from the projection lens 69
 - Replace the lens 70
 - Remove the lens 70
 - Install a new lens 70
 - Calibrate the lens motors 70
 - Replace the lens 70
 - Remove the shroud 71
 - Install the lens 72
 - Filters 75
 - Clean a washable filter 75
 - Clean the light engine air filter 76
 - Clean the liquid cooling air filter 77
 - Clean the IOS filter 78
 - Clean the Laser Module filter 79
- Troubleshooting 80**
 - Projector functionality 81
 - Display issues 82
 - Laser Module functionality 83
- Projector Specifications 85**
 - Power requirements 85
 - Physical specifications 85
 - Operating position 86
 - Operating environment 86
 - Non-operating environment 86

- Projection lens compatibility87
- Accessories87
 - Standard87
 - Optional88
 - Third-party accessories88
 - Replacement air filters88
- Laser Module Specifications 89**
 - Power requirements.89
 - Physical specifications89
 - Operating environment90
 - Non-operating environment90
 - Accessories90
 - Included90
 - Additional90
 - Optional90
- LM Rack Specifications 91**
 - Power requirements91
 - Physical specifications92
 - LM Rack (Full)92
 - LM Rack (Half)92
 - Operating environment93
 - Non-operating environment93
- Regulatory 94**
 - Safety94
 - Laser safety94
 - Electro-magnetic compatibility94
 - Environmental94
 - Certification95

Introduction

This manual is intended for professionally trained operators of the Christie Laser Projection System. These operators are qualified to replace the lens and external air filters, but should not attempt to install or service the projector. In addition, only Christie accredited personnel are authorized to perform security procedures such as marriage.

 WARNING

Failure to comply with the following could result in death or serious injury.

- The components of the Christie Laser Projection System are designed and certified to work together as a unit. Christie components should never be used with third-party components. Use of non-Christie components with Christie systems may pose safety concerns and void your warranty.
- Only Christie qualified technicians who are knowledgeable about the hazards associated with laser use, high-voltage and high temperatures generated by the projector are authorized to assemble, install, and service the Christie Laser Projection System.

General safety precautions

DANGER

Failure to comply with the following results in death or serious injury.

- An incorrect power setup provides a fire and shock hazard. Do not operate the system unless certified connections, providing the recommended voltage, are used. Do not attempt operation unless the power cord, power socket, and power plug meet the appropriate local rating standards.
- Live power is a shock hazard. Only qualified service technicians are permitted to open a projector enclosure, and only if the AC is fully disconnected.

WARNING

Failure to comply with the following could result in death or serious injury.

- A qualified technician is required for all installations.
- The projection head must use Christie laser modules and the LM Rack (Full/Half).
- Use of the rear safety strap on the projector is mandatory to prevent the projector from tipping. Secure the strap between the projector and the optional rack stand or another structure.
- Four or more people are required to safely lift and install the projector.
- Two or more people are required to safely lift and install a Laser Module.
- The extremely high brightness of the projector can cause permanent eye damage. For protection from harmful radiation, keep all projector housings intact during operation.
- Never look directly into the projector lens.
- Concentrated light is a fire hazard. Keep hands, clothes, and all combustible material away from the concentrated light beam of the projector.

CAUTION

Failure to comply with the following could result in minor or moderate injury.

- Wear protective footwear when installing the rack.
- Position all cables where they cannot contact hot surfaces or be pulled or tripped over.

NOTICE

The Laser Modules and the projector must be operated in an environment that meets the operating range specification. For the Laser Modules, see *Operating environment* on page 80; for the projector, see *Operating environment* on page 77. Failure to comply may result in equipment damage.

AC power precautions

WARNING

Failure to comply with the following could result in death or serious injury.

- Loose cables provide a trip or fire hazard. Position all cables where they cannot contact hot surfaces, be pulled, or be tripped over.
- Damaged cables provide a fire hazard. Do not allow anything to rest on the power cord. Never operate the projector if a cable appears damaged.
- Overloaded power outlets and extension cords provide a fire and shock hazard. Do not overload power outlets or extension cords.
- Some attachments and accessories provide a fire, shock, or personal injury hazard. Only use attachments and accessories that are recommended by Christie.

CAUTION

Only qualified service technicians are permitted to open projector enclosures and only if the projector is disconnected from AC power. Failure to comply could result in minor or moderate injury.

Christie Laser Projection System components

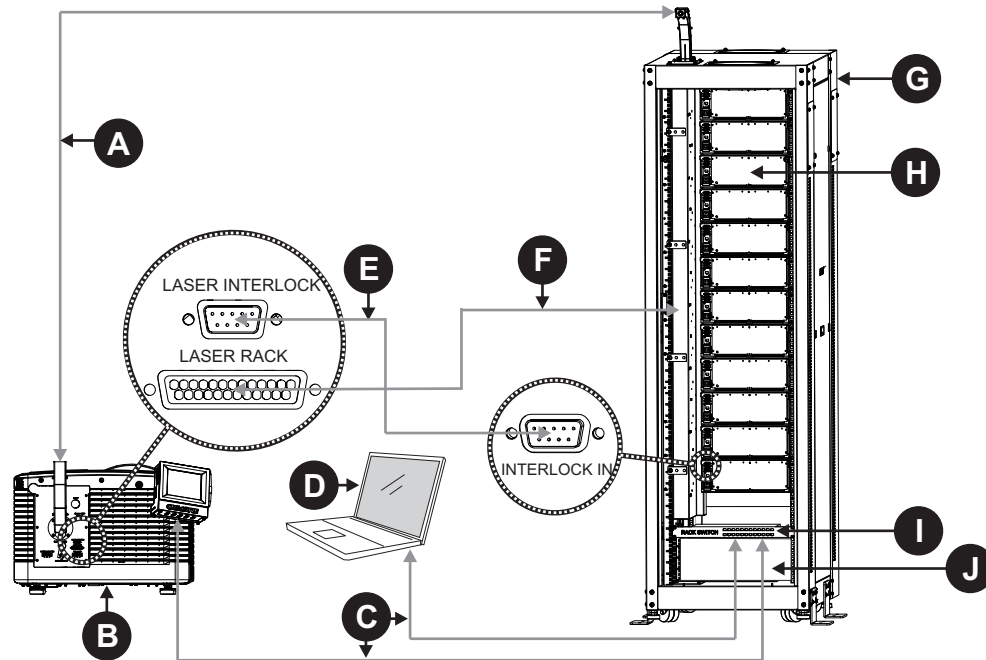

A	Fiber optic bundle Transmits the collected laser light to the projector.
B	Projector Modulates light from the Laser Modules and passes it through a projection lens to produce the image on the screen.
C	Ethernet cables Connects the Laser Bank Manager and the projector to the network.
D	Laser bank manager Runs the Laser Bank Control Application that manages the Laser Modules.
E	Interlock cable (9-pin) Carries the signal for the emergency stop, key switch, and Laser Modules to verify a safe connection between the Laser Modules and the projector.
F	Interlock cable (25-pin) Carries the signal for the Manual Reset button to the projector.
G	LM Rack (Full/Half) (rear side shown) A full and a half rack are available. The LM Rack Full (shown) accommodates up to 12 laser modules, the power distribution unit, and the Laser system network switch and equipped with a key switch and an emergency stop for safety. The LM Rack Half accommodates up to 7 laser modules.
H	Laser module Generates laser light for the projector.

I	Rack switch Provides Ethernet connection to Laser Modules, Laser Bank Manager, and projector.
J	Power distribution unit Contains rectifiers and breakers to provide DC power to Laser Modules.

Laser Safety Precautions

The Christie Laser Projection System components have laser classifications, as outlined by the International Electrotechnical Commission (IEC), ranging from Class 1 to Class 4. Immediate skin hazard and eye hazard can occur from exposure to either the direct or specular reflected beam. This may pose a fire hazard or a diffuse reflection hazard.

- Wavelength: 435 nm to 660 nm
- Beam divergence: 0.1 rad to 0.96 rad, lens dependent
- Pulse pattern: Continuous Wave (CW).
- Maximum output: < 10 W

 DANGER

Failure to comply with the following results in death or serious injury.

- This product must be installed within a restricted access location which is normally inaccessible by the general public, including workers, visitors, and residents in the immediate vicinity, by means of engineering or administrative control measures but is accessible to authorized personnel that have had specific safety training.
- The installation setup must prevent access to the nominal ocular hazard area.

 WARNING

Failure to comply with the following could result in death or serious injury.

- A qualified technician is required for all installations.
- Never look into the end of a fiber optic cable while the device is operational. Laser radiation can be harmful to the human eye and injury may occur.
- Invisible infrared LED radiation might be emitted from disconnected fibers or connectors. Do not stare into beams or view directly with optical instruments.
- Lasers contain a high energy density. These can be dangerous for skin tissue as well as pose an electrical, chemical, and non-ionizing radiation hazard.
- Do not operate the Christie Laser Projection System with the laser rack access panels removed.

 CAUTION



Failure to comply with the following could result in minor or moderate injury.

- Turn the laser module breakers off before inspecting the fiber optic cable.
- Use of controls or adjustments or performance of procedures other than those specified herein may result in hazardous radiation exposure.

Laser module laser safety labels

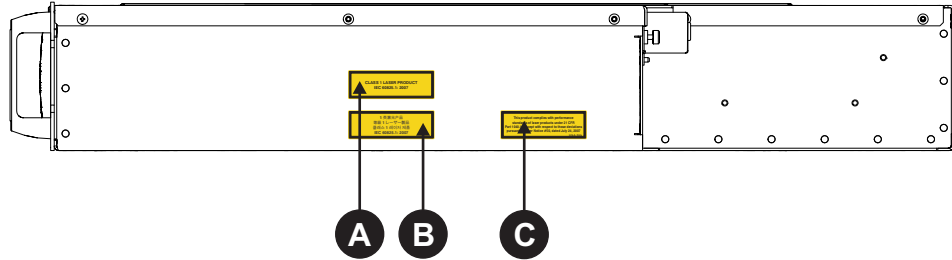
This diagram shows the laser safety labels on the right side of the Laser Module.



<p>A</p>		<p>CLASS 1 LASER PRODUCT IEC630825-1: 2007</p>
<p>B</p>		<p>Translation of label A in French, Chinese, Japanese, and Korean</p>
<p>C</p>		<p>Christie Digital Systems Canada Inc. 809 Wellington Street North Kitchener, ON N2G 4Y7 Canada</p> <p>This product complies with performance standards of laser products under 21 CFR Part 1040.10 except with those deviations pursuant to Laser Notice #50, dated July 24, 2007 U.S.A. Only</p>

This diagram shows labels below the Laser Module cover.



Do not remove the Laser Module cover for maintenance or service. The Laser Module must be repaired at a Christie Digital Factory. Removing the cover voids the warranty. Failure to comply could result in death or serious injury.

- Wavelength: 435 nm to 660 nm
- Beam divergence: 10 mrad
- Pulse Pattern: Continuous Wave
- Maximum power: 64 W

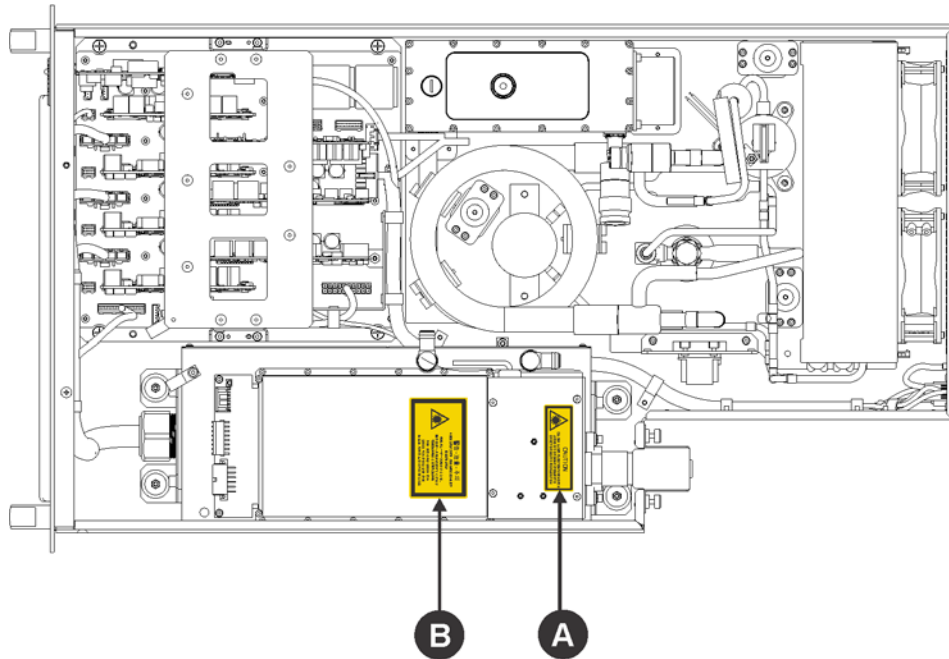

A		<p>CAUTION CLASS 4 LASER RADIATION WHEN OPEN AVOID EYE OR SKIN EXPOSURE TO DIRECT OR SCATTERED RADIATION</p>
B		<p>Translation of label A in French, Chinese, Japanese, and Korean</p>

LM Rack laser safety labels



This diagram identifies laser safety labels on the laser rack underneath the operator side door.

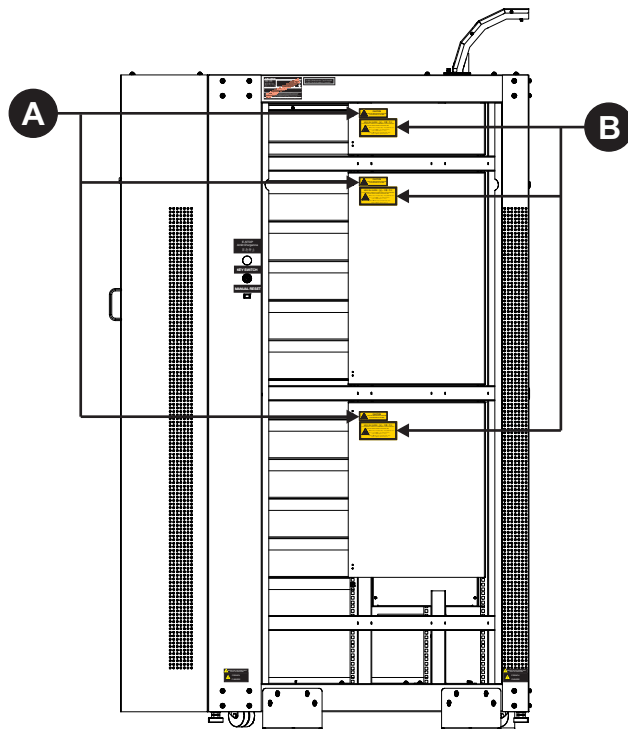

The laser rack contains a Class 3B laser product. Do not disassemble components in the laser rack. Disassembling components voids the warranty. Failure to comply result in death or serious injury.

- Wavelength: 435 nm to 660 nm
- Beam divergence: 260 mrad
- Pulse Pattern: Continuous Wave
- Maximum power: 100 mW





<p>A</p>		<p>CAUTION CLASS 3B LASER RADIATION WHEN OPEN AVOID EXPOSURE TO BEAM</p>
<p>B</p>		<p>Translation of label A in French, Chinese, Japanese, and Korean</p>

Projector laser safety labels

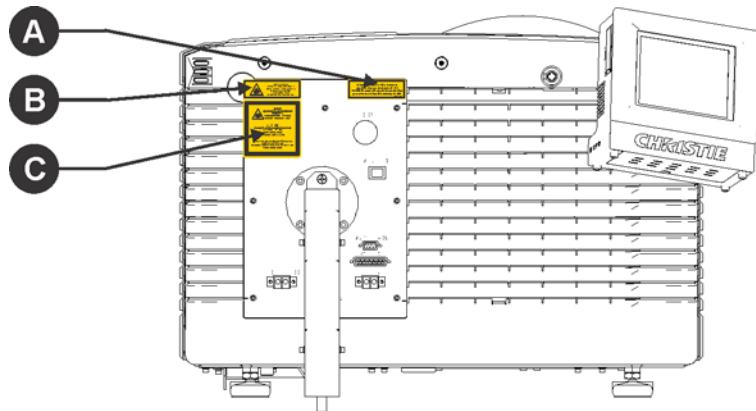
This diagram shows the laser safety labels on the operator side of the projector.

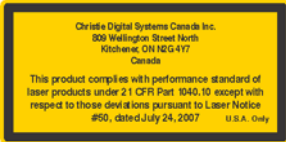

<p>A</p>		<p>Christie Digital Systems Canada Inc. 809 Wellington Street North Kitchener, ON N2G 4Y7 Canada</p> <p>This product complies with performance standards of laser products under 21 CFR Part 1040.10 except with respect to those deviations pursuant to Laser Notice #50, dated July 24, 2007 U.S.A. Only</p>
<p>B</p>		<p>LASER RADIATION AVOID EYE OR SKIN EXPOSURE TO DIRECT OR SCATTERED RADIATIONS CLASS 4 LASER PRODUCT 435nm-660nm <10W CLASSIFIED PER IEC 60825-1 2007</p>
<p>C</p>		<p>Translation of label B in French, Chinese, Japanese, and Korean</p>

This diagram shows the laser safety labels on the lens side of the projector.

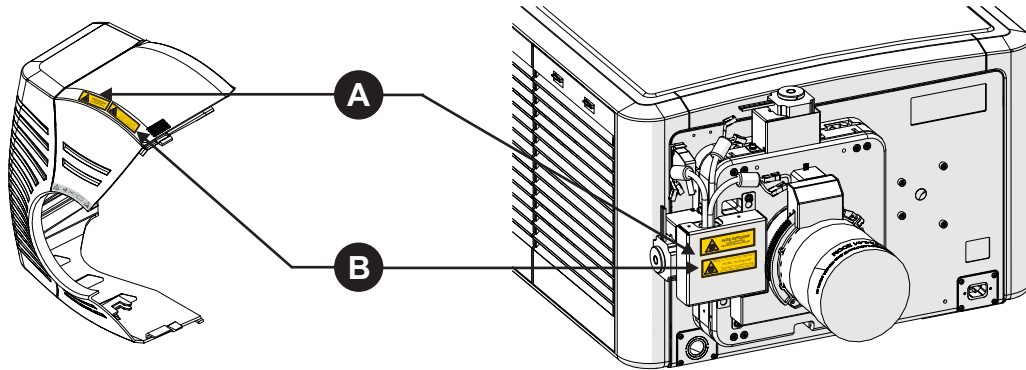

A		<p>AVOID EXPOSURE LASER RADIATION IS EMITTED FROM THIS APERTURE</p>
B		<p>Translation of label A in French, Chinese, Japanese, and Korean</p>

This diagram shows the laser safety labels that appear on the fiber bundle relay optics.



WARNING

Do not remove the protective housing. Failure to comply could result in death or serious injury.

- Wavelength: 435 nm to 660 nm
- Beam divergence: 260 mrad
- Pulse Pattern: Continuous Wave
- Maximum power: 775 W

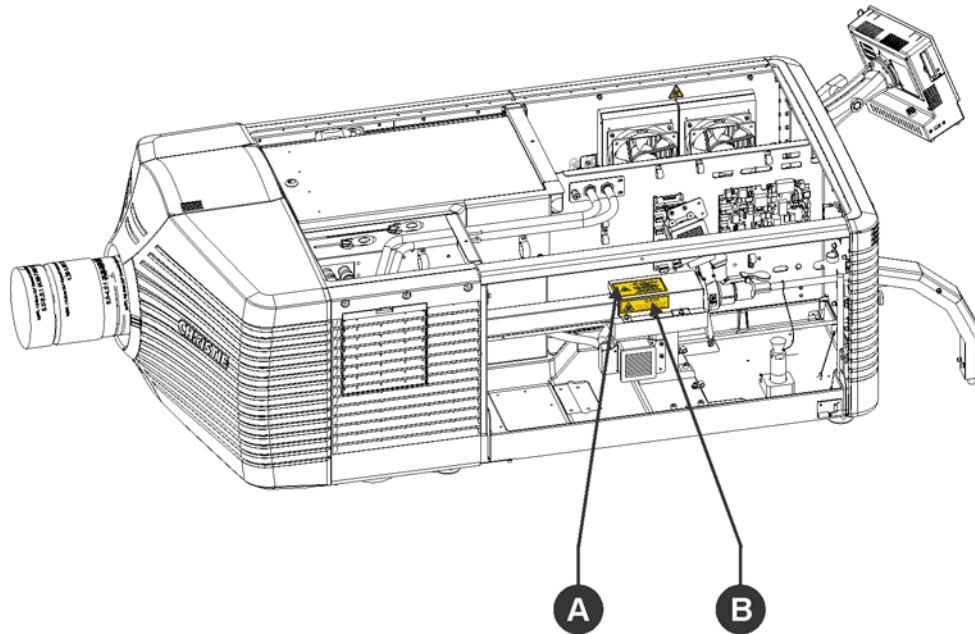

A		<p>CAUTION CLASS 4 LASER RADIATION WHEN OPEN AVOID EYE OR SKIN EXPOSURE TO DIRECT OR SCATTERED RADIATION</p>
B		<p>Translation of label A in French, Chinese, Japanese, and Korean</p>

Laser module status lights

This diagram shows the location of the Laser Module LED status lights. The Laser Module is off when the Power LEDs are off.

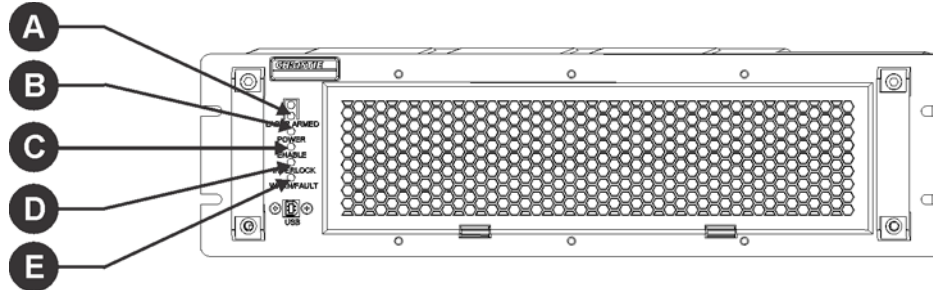

LED	Red	Green	Amber	White
A LASER ARMED				Armed (Interlocks OK, lasers are charged; may or may not be emitting)
B POWER		On (lasers are active and emitting)	Standby (Chiller and fans running)	
C ENABLE				Lasers are active and emitting
D INTERLOCK	Not blinking: external interlock failure Blinking: IR interlock failure	OK		
E WARN/FAULT	Fault (Laser Module does not turn on or has turned off)	No fault	Warning (Laser Module is on but a laser temperature or voltage is above the warning threshold)	

LM Rack safety features

This diagram shows the laser safety features on the operator side of the laser rack.

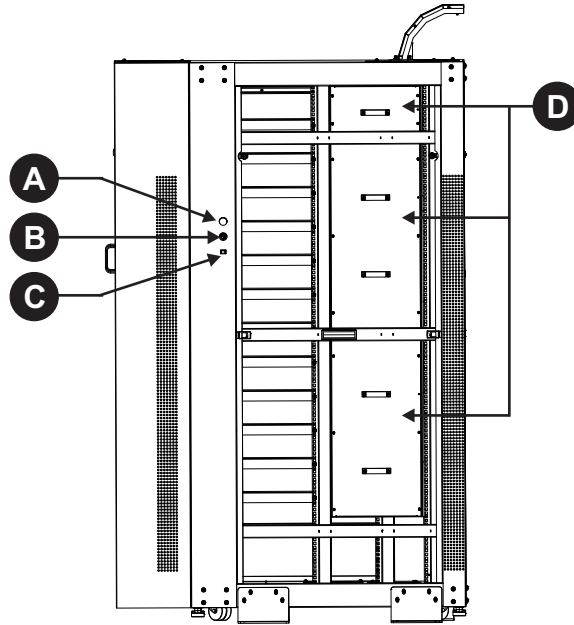

A	Emergency stop To shut down the Laser Modules in an emergency, press E-stop .
B	Key switch Key must be present for the system to run. Laser radiation is not accessible when the key is removed.
C	Manual reset Press Reset following a system restart.
D	Fiber carrier panel When any panel is removed, the laser interlock opens and the lasers cannot be armed.

Projector safety features

This diagram shows the location of the laser safety features on the projector.

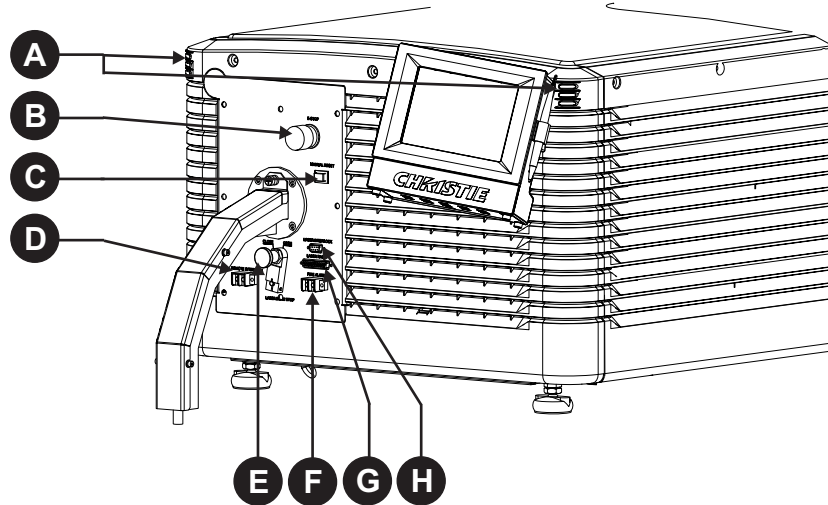

A	<p>Laser emission indicator lights</p> <p>Bottom two LEDs on both sides emit white light when the lasers are armed. They are off when the lasers are not armed.</p>
B	<p>Emergency stop</p> <p>Turns off the Laser Modules off in an emergency.</p>
C	<p>Manual reset</p> <p>Re-arms the system after a system shutdown. Pressing Manual Reset indicates it is safe to arm the lasers.</p>
D	<p>Remote interlock</p> <p>Enables remote shutdown of the projector (optional).</p>
E	<p>Laser beam stop</p> <p>Blocks the laser light path. Rotate the beam stop to Closed when performing service or maintenance on the projector. The laser projector system cannot be armed when the laser beam stop is closed.</p>
F	<p>Fire alarm</p> <p>Enables the projector to be connected to the facility fire alarm system (optional). When the alarm is activated, the Laser Modules turn off.</p>
G	<p>LM Rack (interlock)</p> <p>Connects the projector to the laser rack.</p>
H	<p>Laser interlock</p> <p>Connects the projector to the Laser Modules. When the interlock is tripped, accessible radiation is reduced below the maximum permissible exposure (MPE) level.</p>

Nominal ocular hazard distance



The installation setup must prevent access to the nominal ocular hazard area. Failure to comply results in death or serious injury.

The nominal ocular hazard distance (NOHD) is the distance from the projector where the light exceeds the maximum permissible exposure (MPE) on the eye and eye injuries can occur. The Skin Nominal Hazard Zone (SNHZ) is the area where skin burns are possible. This diagram illustrates the typical SNHZ (A), the NOHD (A + B), and the area (C) that is within permissible limits:

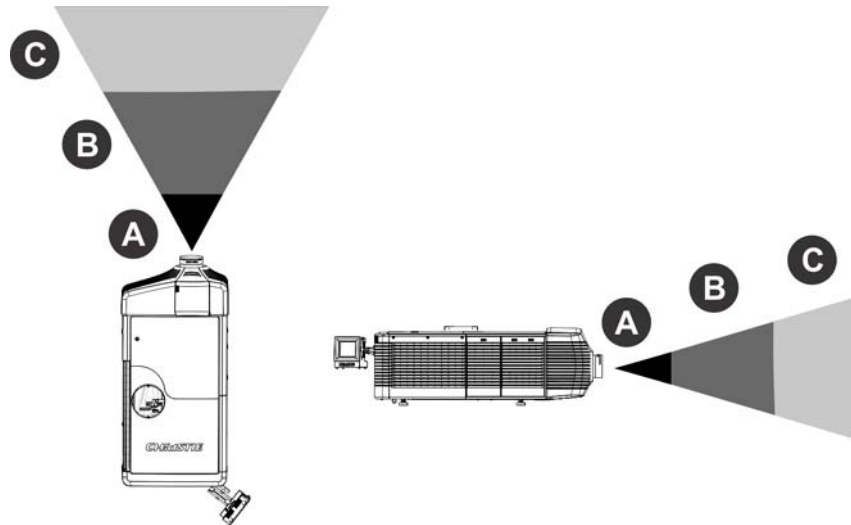

Hazard calculations are dependent on the number of light modules and the lens installed. This table lists hazard distances for Christie projector lenses with the zoom adjusted to its most hazardous position. Contact Christie support for assistance calculating hazard distances specific to your installation.

Light Modules	Projection Lens	4K Throw Ratio	Extended Source NOHD (m)	Skin NHZ (m)
7	1.25-1.45 DLPCine HB Zoom Lens (108-274101-01)	1.31:1	1.65	0.50
12	1.25-1.45 DLPCine HB Zoom Lens (108-274101-01)	1.31:1	2.8	0.65
7	1.25-1.83 DLPCine HB Zoom Lens (108-342100-01)	1.66:1	2.05	0.60
12	11.25-1.83 DLPCine HB Zoom Lens (108-342100-01)	1.66:1	3.50	0.80
7	1.45-2.05 DLPCine HB Zoom Lens (108-335102-01)	1.86:1	2.30	0.70
12	1.45-2.05 DLPCine HB Zoom Lens (108-335102-01)	1.86:1	3.90	0.80
7	1.6-2.4 DLPCine HB Zoom Lens (108-336103-01)	2.17:1	2.65	0.75
12	1.6-2.4 DLPCine HB Zoom Lens (108-336103-01)	2.17:1	4.55	1.05
7	1.8-3.0 DLPCine HB Zoom Lens (108-337104-01)	2.71:1	3.30	0.80
12	1.8-3.0 DLPCine HB Zoom Lens (108-337104-01)	2.71:1	5.65	1.30

Light Modules	Projection Lens	4K Throw Ratio	Extended Source NOHD (m)	Skin NHZ (m)
7	2.15-3.6 DLPCine HB Zoom Lens (108-338105-01)	3.26:1	3.95	1.20
12	2.15-3.6 DLPCine HB Zoom Lens (108-338105-01)	3.26:1	6.80	1.55
7	3.0-4.3 DLPCine HB Zoom Lens (108-278101-01)	3.89:1	4.70	1.40
12	3.0-4.3 DLPCine HB Zoom Lens (108-278101-01)	3.89:1	8.05	1.85
7	4.3-6.0 DLPCine HB Zoom Lens (108-279101-01)	5.43:1	6.55	2.00
12	4.3-6.0 DLPCine HB Zoom Lens (108-279101-01)	5.43:1	11.25	2.60
7	5.5-8.0 DLPCine HB Zoom Lens (108-280101-01)	7.24:1	8.75	2.65
12	5.5-8.0 DLPCine HB Zoom Lens (108-280101-01)	7.24:1	14.95	3.45

This table lists hazard distances for Christie projector high contrast lenses with the zoom adjusted to its most hazardous position.

Light Modules	Projection Lens	4K Throw Ratio	Extended Source NOHD (m)	Skin NHZ (m)
7	1.13-1.66:1 DLPCine HC Zoom Lens (108-400105-01)	1.66:1	2.25	0.60
12	1.13-1.66:1 DLPCine HC Zoom Lens (108-400105-01)	1.66:1	3.85	0.80
7	1.31-1.85:1 DLPCine HC Zoom Lens (108-401106-01)	1.86:1	2.50	0.70
12	1.31-1.85:1 DLPCine HC Zoom Lens (108-401106-01)	1.86:1	4.30	0.90
7	1.45-2.17:1 DLPCine HC Zoom Lens (108-402107-01)	2.17:1	2.95	0.80
12	1.45-2.17:1 DLPCine HC Zoom Lens (108-402107-01)	2.17:1	5.00	1.05
7	1.63-2.71:1 DLPCine HC Zoom Lens (108-403108-01)	2.71:1	3.65	1.00
12	1.63-2.71:1 DLPCine HC Zoom Lens (108-403108-01)	2.71:1	6.25	1.30
7	1.95-3.26:1 DLPCine HC Zoom Lens (108-404109-01)	3.26:1	4.35	1.20
12	1.95-3.26:1 DLPCine HC Zoom Lens (108-404109-01)	3.26:1	7.50	1.55

Operate the Projector and Run Diagnostics

This section describes how to operate the projector and run projector diagnostic utilities.

The Touch Panel Controller

The TPC is a touch-sensitive screen used to control the projector. You can use the TPC to turn the projector and the Laser Modules on or off, select channels, and view status information. The TPC is mounted on the rear of the projector. You can tilt and turn the TPC to improve the viewing angle. Use the USB port on the side of the TPC to download log files and install software upgrades. You can disconnect the TPC from the projector and you can control the projector from a maximum distance of 30 meters (98 feet) with an optional cable.

The Main screen

Use the Main screen of the Touch Panel Controller (TPC) to access power, lasers, douser, channel, and test pattern settings.

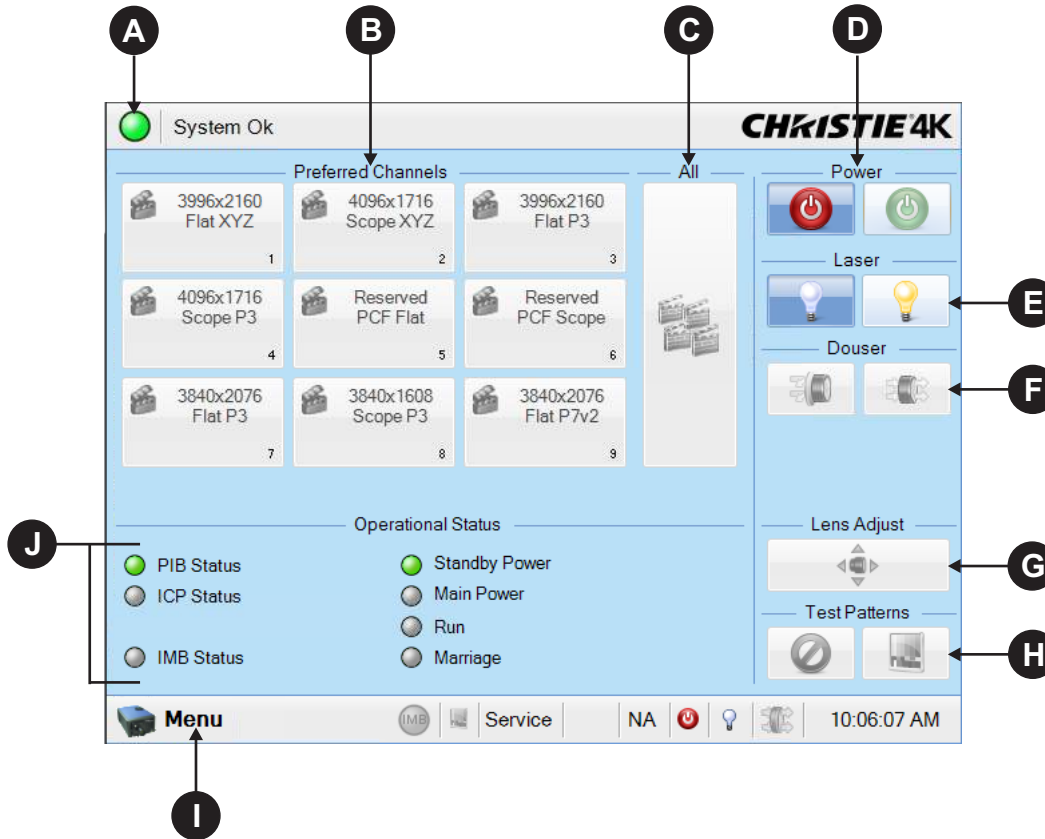

A	A green LED indicates that the projector is operating properly. If a monitored system falls below a normal reading, the LED is yellow or red. A yellow LED indicates a warning and a red LED indicates a critical error you must correct. Click the status LED to open the Status window and resolve issues.
B	Displays custom projector settings.
C	Displays 64 saved channels.
D	Turns the projector on or off. Tap Off to place the projector in stand-by mode. To prevent accidental activation, tap and hold On or Off . A message displays in the title bar when the projector turns on or off.
E	Turns the lasers on or off. To prevent accidental activation, tap and hold On or Off .
F	Opens or closes the douser.
	Controls the Intelligent Lens System (ILS) lens motors. Tap to open the ILS File Setup window.
H	Selects or disables test patterns. To open the Preferred Test Patterns window, tap the Test Pattern .
I	To access projector menu, tap Menu .

J	Displays the status of projector functions including the Projector Intelligence Board (PIB), the Integrated Cinema Processor Board (ICP), the Integrated Media Block (IMB), Standby Power, Main Power, Run, and Marriage. A green LED indicates the system is functioning correctly. A red LED indicates a critical error you must correct. Click the status LED to open the Status window and resolve issues.
---	--

Turn the system on

1. Check the interlock cables are securely attached to the Laser Modules.
2. Check the interlock cable to the projector is securely attached.
3. Check the Ethernet cable between the projector and the Rack Switch is securely attached.
4. Check the Ethernet cable between the Laser Bank Manager and the Rack Switch is securely attached.
5. Turn the Rack Switch on.
6. Turn on the Laser Bank Manager.
7. Turn on the circuit breaker on the projector baseplate under the front lens-side corner.
8. If the emergency-stop button on either the Laser Rack or the projector is activated, release it by turning the button clockwise.
9. Turn the Beam Stop on the projector to **OPEN**.
10. Turn the Laser Rack key switch on.
The key must be in the switch at all times.
11. Turn on the Rack Switch at the rear of the Laser Rack.
12. Turn on the breakers (one per Laser Module) in the power distribution unit in the front of the Laser Rack.
13. Press **MANUAL RESET** on the side of the Laser Rack or on the back of the projector.
14. Verify the status lights on the back of the projector and the front of the Laser Modules are white.

The projector is armed, but the lasers are off.

Test the interlocks

Once the projector is running, ensure the safety interlocks are functioning.



Before displaying an image from the projector, test the three interlock devices. Every time the interlock is activated, the Laser Modules turn off. Failure to comply could result in death or serious injury.

Test the key switch

1. Turn the key switch on the Laser Rack off.
2. Check the status lights on the back of the projector are off.

3. Turn on the key switch.
4. Press **Manual Reset** on the projector.

Test the Laser Rack emergency stop

1. Press the emergency stop button on the Laser Rack.
2. Check the status lights on the back of the projector are off.
3. To release the E-stop, rotate the knob clockwise.
4. Press **Manual Reset** on the projector.

Test the projector emergency stop

1. Press the emergency stop button on the projector.
2. Check the status lights on the back of the projector are off.
3. To release the E-stop, rotate the knob clockwise.
4. Press **Manual Reset** on the projector.

Log on to the projector

1. Tap **Menu > Login**.
2. Select a user name in the **Username** list.
3. In the **Password** field, type a password.
4. Tap **Login**.

Laser emission indicator lights

The bottom two LEDs on the rear corners of the projector indicate when the lasers are armed.

LEDs	Status
White	Lasers are armed and may or may not be emitting light.
Off	Lasers are not armed.

View the status of projector components

1. Tap **Menu > Status**.

The Status window displays information about the status of projector components. The right pane lists projector components and their status. The left pane displays detailed information about individual projector items.

- Green LED indicates the item is functioning correctly.
- Yellow LED indicates an item requires attention.
- Red LED indicates an item requires immediate attention.

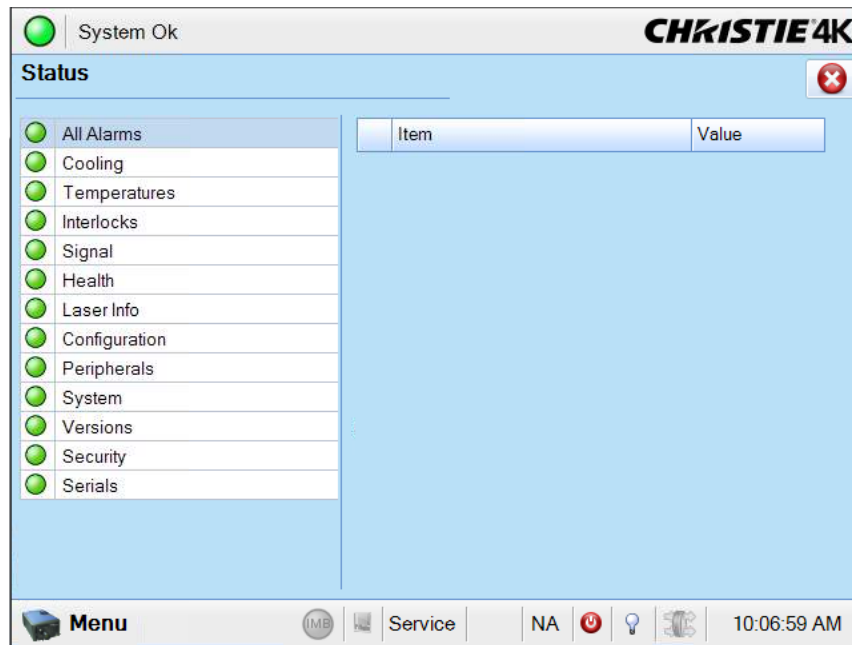

If the Item or Value descriptions are too long for the cell, click the description to display the full description at the bottom of the window. To adjust the width of a column in the left pane, tap and drag the column border. When you close the Status window, the column widths return to their default size.

Respond to alarms

When an alarm occurs, an Alarms window with a red border appears with a description of the alarm condition, state, and time and date of the alarm. The window only displays alarms you have not previously acknowledged.

1. To acknowledge an alarm and remove it from the Alarms window, click **Acknowledge**.
2. To view all alarms, in the left pane, tap **Menu > Status > All Alarms**.

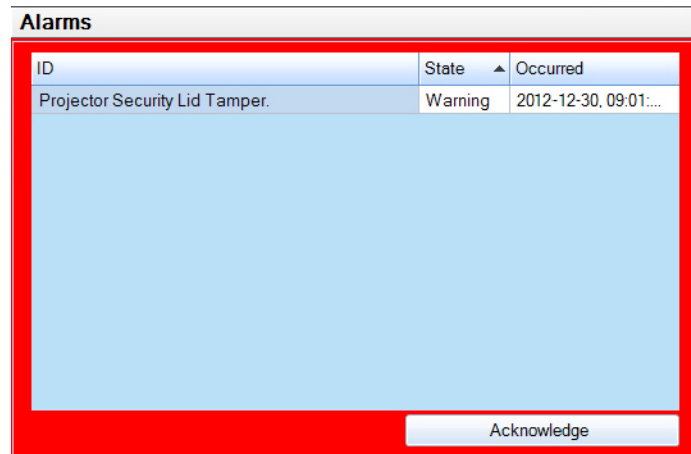

Run the projector interrogator

The interrogator captures diagnostic information that you can use to assist Christie service personnel diagnose and correct projector issues. To access the Interrogator menu, you need Operator, Administrator, or Service permissions. When you run the interrogator, you cannot modify projector settings.

Image disruption can occur if you run the interrogator when content is playing.

Log files are compressed into a 7z or 7-zip file format. A tool for opening these archives can be downloaded from <http://www.7-zip.org>.

1. Tap **Menu > Diagnostics > Interrogator**.
2. To obtain the projector log files only, tap **Basic Mode**.
3. To obtain projector log files and registered batch files, tap **Enhanced Mode**.

You cannot run an enhanced mode request when the lasers are on.

4. Tap **Yes**.
5. Insert a USB flash drive in the USB port on the side of the touch panel controller (TPC).
6. Tap **Download to USB**.

View SMPTE errors

The SMPTE Errors window displays a numerical representation of the signal integrity of the HD-SDI signals sent to the projector on the Bayonet Niell-Concelman (BNC) signal cables.

1. Tap **Menu** > **Diagnostics** > **SMPTE Errors**.

Clear SMPTE errors

1. Tap **Menu** > **Diagnostics** > **SMPTE Errors**.
2. Tap **Clear Errors**.

Retrieve system logs

System logs can help you identify and correct projector issues. To retrieve system logs you need Operator, Administrator, or Service permissions.

1. Tap **Menu** > **Diagnostics** > **System Logs**.
2. Select a start date for the logs in the **From** list.
3. Select an end date for the logs in the **To** list.
4. Select a log type in the **Type** list.
5. Select the severity type in the **Severity** list.
6. Tap **Retrieve Logs**.
7. To download the log files to a USB:
 - a. Insert a USB flash drive in the USB port on the side of the touch panel controller (TPC).
 - b. Tap **Download to USB**.

Run a server test

You can run a server test to search the subtitle and metadata .xml files for errors in content or in transmission from the server. You cannot use a server test to turn metadata or subtitling off or on.

1. Tap **Menu** > **Diagnostics** > **Server Test**.
2. To search the metafile, type the location of the metafile in the **Meta File URI** field.
3. To search the subtitle file, type the location of the subtitle file in the **Subtitling URI** field.

Turn the projector off

1. On the Touch Panel Controller (TPC), tap and hold the light bulb  icon to turn the lasers off.

2. On the TPC, tap and hold the red power  icon.

The projector enters standby mode.

If performing maintenance on the projector or removing the outer skins, disconnect the projector from AC power. See [Shut down for maintenance](#) on page 67.

Turn the system off in an emergency

1. To shut down the system in an emergency, press **E-Stop** on the back of the projector (see [Projector safety features](#) on page 22) or on the operator side of the Laser Rack (see [LM Rack safety features](#) on page 21).

The Laser Modules turn off.

Manage the DLP

This section provides procedures for managing the Integrated Cinema Processor (ICP) electronics. To access the DLP menus, you need Administrator or Service permissions.

Run a DLP self test

Run a DLP self test to test the functionality of the Integrated Cinema Processor (ICP) and DLP.

1. Tap **Menu > Diagnostics > DLP Management**.
2. Tap **DLP Self Test**.
3. Tap **Yes**.
4. To close the Results pane, tap **Clear Results**.

Download an ICP certificate

1. Insert a USB flash drive in the USB port on the side of the touch panel controller (TPC).
If you do not insert a USB flash drive, the ICP certificate is saved to the FTP root directory.
2. Tap **Menu > Diagnostics > DLP Management**.
3. Tap **Download ICP Certificate**.
4. Tap **Close**.

Disable the ICP signature test

Error messages appear when the ICP is turned on and the ICP signature test is run. They can disrupt projector network monitoring. Use this procedure to disable the signature test.

1. Tap **Menu > Diagnostics > DLP Management**.
2. Tap **Bypass Signature Test**.
3. Tap **Yes**.
4. To re-enable the ICP signature test, clear the **Bypass Signature Test** checkbox.

Work with Channels

Create channels to store customized projector settings for different inputs. You can create a maximum of 64 channels.

Create a new channel

You need Advanced, Administrator, or Service permissions to create or modify channel settings. You can create a maximum of 64 channels.

1. Tap **Menu > Channel Setup**.
2. Tap the **Launch Dialog**  icon.
3. Type a name for the channel and tap **Enter**.
4. Complete these fields on the Config 1 screen:

Field	Description
Icon	The icon associated with the channel.
Input	The device associated with the channel.
Data Format	The source color depth (8-10-12 bit) for the channel.
Source File	The resolution and aspect ratio for the channel.
Screen File	The screen type, masking, cropping, and lens settings for the channel.
Use PCF	Associates the channel with a Projector Configuration File (PCF) and prevents Channel adjustments.
PCF	The PCF file associated with the channel.
Laser File	The laser file associated with the channel.
Use ILS	Associates the channel with a Intelligent Lens System (ILS) file.
ILS File	The ILS file associated with the channel. The ILS file automatically adjusts the lens position so the content displays correctly. Tap Launch Dialog to edit the ILS file settings. Any changes made to the ILS File settings are applied to all channels that use this ILS file.

5. Tap **Config 2** in the left pane and then complete these fields:

Field	Description
Measured Color	The Measured Color Gamut Data (MCGD) file used to calculate target color processing.

Field	Description
Target Color	The Target Color Gamut Data (TCGD) value. This option is not available when Use PCF is selected in the Config 1 screen.
Color Space	The method of color decoding for the current source. The default is YCbCr for all DVI sources. The default for all cinema sources is Unity RGB. This option is not available when Use PCF is selected.
Gamma	The gamma correction required for the proper tonal range of the source material. This option is not available when Use PCF is selected.
LUT_CLUT	Applies a 3D color cube for increased color accuracy. This option is not available when Use PCF is selected.
Scan Type	The video scan type. The default is Progressive .
Automatic Scan Type Detection	Automatically performs scan type detection. This feature is supported for PIB inputs only.
Use PCT	Applies Christie Pureformity Color Technology (PCT) to the channel.
PCT File	Identifies the Christie Pureformity Color Technology (PCT) file associated with the channel.
HDMI EDID Type	Identifies the extended display identification data (EDID) type used by the channel when playing content from a device connected to the HDMI A/LEFT or HDMI B/RIGHT ports.
Enable 3D Dual Measured Color	Enables 3D Dual Measured Color on the channel. Select the color files for the left and right eyes.

6. Tap **3D Control** in the left pane if the channel will be used to display 3D content. Complete these fields:

Field	Description
Enable 3D	Enables 3D.
3D Test Patterns	Displays 3D test patterns.
3D Sync Input Mode	Specifies whether a specific frame of input data has left eye or right eye data. Select Use White Line Code (true and inverted) if using a single 3D input signal in which an embedded white line at the bottom of each frame identifies left and right, and an additional separate 3D stereo sync input at the GPIO port is not present. The bottom row of the left-eye sub-field should be pure white for the left-most 25% of the pixel row and pure black for the remainder of the row. The bottom row of the right-eye sub-field should be pure white for the left-most 75% of the pixel row and pure black for the remainder of the row. Select Use Line Interleave for 3D source data only. When specified, the ICP de-interleaves each line into the left image or right image in memory as specified. Line interleave can be used with PsF 3D data (left and right data for one field, then left and right data for second field).
L/R Display Reference	Specifies which frame of eye data to display during a specific display frame. This signal is referenced to the display frame rate which is specified by the Frame Rate N:M.
Frame Rate N:M	Sets how many frames to display per number of frames that form one complete image. Increase the display frame rate to reduce flicker from your source(s).

Field	Description
L/R Display Sequence	<p>Defines the frame order (L-R or R-L) required for 3D perspective. This option only has meaning when the Frame Rate factor M is equal to 2. For this case, 2 input frames of data are required to constitute a complete frame of image data. This parameter tells the system which frames go together to make a complete image.</p> <p>Note: <i>When using Line Interleave as the 3D Sync Input Mode, ensure that Left (L1R1 L2R2) is selected.</i></p>
3D Sync Polarity	<p>Keeps 3D stereo sync output the same as input (true) or reversed (inverted).</p> <p>True: 3D L/R sync output from GPO will match L/R sync input.</p> <p>Inverted: 3D L/R sync output from GPO will be the opposite of sync input (left = right, right = left).</p>
Dark Time	<p>Creates a blank time interval between left and right frames to allow for LCD shutter glasses, Z screen, or rotating 3D wheel to synchronize the output. See Dark Time and Output Delay Notes below. Values between 0 and 65535 are accepted. To enter the dark time value, tap Launch Dialog .</p>
Output Delay	<p>The non-image time in Microseconds (μ). Offset 3D stereo sync output in relation to dark time interval. Acceptable values are between -32768 and 32767. A positive offset adds a delay and a negative offset starts playback early. To enter the output delay value, tap Launch Dialog.</p>
Phase Delay	<p>The degree of reference between the left and right sync output. Values between -180 and 180 are accepted. To enter the phase delay, tap Launch Dialog.</p>

7. To activate the channel, tap **Activate**.

Activate a channel

1. Tap **Menu > Channel Setup**.
2. Select a channel in the **Channel Name** list.
3. Tap **Activate**.

Restore default channel settings

1. Tap **Menu > Channel Setup**.
2. Select a channel in the **Channel Name** list.
3. Tap **Defaults**.
4. To restore the default settings to the selected channel, tap **Default Current Channel**.
5. To restore the default settings to all channels, tap **Default All Channels**.
6. Tap **OK**.

Change the channel icon

1. Tap **Menu > Channel Setup**.
2. Select a channel in the **Channel Name** list.
3. Tap **Icon**.
4. Tap an **Icon**.
5. Tap **OK**.

Add or remove preferred channels from the Preferred Channels pane

You need Administrator or Service permissions to complete this procedure.

1. Tap **Menu > Administrator Setup > Preferred Channel Setup**.
2. To add a channel to the Preferred Channels pane, tap and drag a channel from the **All Channels** list to the **Selected Channel Buttons (Drag and Drop)** pane.
3. To remove a channel from the Preferred Channels pane, tap and drag a channel from the **Selected Channel Buttons (Drag and Drop)** pane to the recycle bin in the bottom right corner.

Manage Projector Setting Files

Advanced, administrator, service, or marriage permissions are required to complete the procedures in this section.

Create a source file

Create source files to store resolution, offset, and aspect ratio settings for input devices.

1. Tap **Menu** > **Advanced Setup** > **Source File Setup**.
2. Tap **Save As**.
3. Type a name for the source file in the **Filename** field.
4. Tap **OK**.
5. Enter values in these areas:

Area	Description
Resolution	The X and Y resolution of the incoming signal. For example, 2048 (X) and 858 (Y) or 1920 (X) and 1080 (Y). The resolution must match the incoming signal format.
Offset	The amount of incoming data to discard. Set the values to zero to process all incoming data. The allowable X range is -4096 to 4096 pixels and Y range of -2160 to 2160 pixels.
Aspect Ratio	The aspect ratio for the incoming signal. The allowable range is 0 to 7.99.

6. Tap **Save**.

Modify a source file

1. Tap **Menu** > **Advanced Setup** > **Source File Setup**.
2. Select a source file in the **Current Source File** list.
3. Modify the **Resolution**, **Offset**, or **Aspect Ratio** values.
4. Tap **Save**.

Create a screen file

Use screen files to define the size of the display panel and image cropping. You can assign the same screen file to multiple input devices.

1. Tap **Menu** > **Advanced Setup** > **Screen File Setup**.
2. Tap **Save As**.
3. Type a name for the source file in the **Filename** field.
4. Tap **OK**.
5. Complete these fields:

Field	Description
Letter Box	All image data is displayed and the aspect ratio is maintained.
Lens Factor	The amount to stretch an image horizontally. Allowable values can range from 0.00 to 7.99. Type 1 if not using an anamorphic lens.
Presentation	The size and location of the image. By default, the projector uses a 2048 x 1080 panel.
Cropping	Hides unwanted image data.

6. Tap **Save**.

Modify a screen file

1. Tap **Menu** > **Advanced Setup** > **Screen File Setup**.
2. Select a screen file in the **Current Screen File** list.
3. Modify the screen file settings.
4. Tap **Save**.

Create a MCGD file

Create Measured Color Gamut Data (MCGD) files to correct on-screen colors. A colorimeter is required to complete this procedure.

1. Turn the lasers on and allow it to operate for 20 minutes.
2. Tap **Menu** > **Advanced Setup** > **MCGD File Setup**.
3. Tap **Save As**.
4. Type a name for the MCGD file in the **Filename** field.
5. Tap **OK**.
6. If the MCGD file will be associated with a 3D channel, tap **Enable 3D** and select a frame rate in the **Frame Rate N:M** list.

7. To display the red test pattern, in the red area of the chromaticity image tap **Option**.
8. Measure the red chromaticity with the colorimeter.
9. Record the red chromaticity value.
10. Repeat steps 5 to 8 for the green, blue, white, and black chromaticity measurements. Select the test pattern that matches the color you are measuring.
11. Enter the chromaticity measurements you recorded in steps 8 and 9 in the red, green, blue, white, and black **x** and **y** fields.
12. Tap **Save**.

Modify a MCGD file

1. Tap **Menu** > **Advanced Setup** > **MCGD File Setup**.
2. Select a MCGD file in the **Current Measured (MCGD) File** list.
3. Modify the MCGD file settings.
4. Tap **Save**.

Create a TCGD file

Typically, Target Color Gamut Data (TCGD) file settings are defined by the content provider and are not modified.

1. Turn the lasers on and allow it to operate for 20 minutes.
2. Tap **Menu** > **Advanced Setup** > **TCGD File Setup**.
3. Tap **Save As**.
4. Type a name for the TCGD file in the **Filename** field.
5. Tap **OK**.
6. Tap **Display Test Pattern**.
7. To display the red test pattern, in the red area of the chromaticity image, tap **Option**.
8. Measure the red chromaticity with the colorimeter.
9. Type the red chromaticity values in the **x**, **y**, and **Gain** fields.
10. Repeat steps 6 to 9 for the magenta, blue, white, yellow, and green chromaticity measurements. Select the test pattern that matches the color you are measuring.
11. Tap **Save**.

Modify a TCGD file

Modifying a Target Color Gamut Data (TCGD) alters the color of the projected image.

1. Tap **Menu** > **Advanced Setup** > **TCGD File Setup**.
2. Select a TCGD file in the **Current Target (TCGD) File** list.
3. Modify the TCGD file settings.
4. Tap **Save**.

Create a new ILS file

1. Tap **Menu** > **Advanced Setup** > **ILS File Setup**

The ILS File Setup window is not available if the **Enable Automatic ILS** option is not selected on the Lens Setup window. See [Enable automatic ILS on a lens](#) on page 43.

2. Tap **Save As**.
3. In the **Filename** field, type a name for the ILS file.
4. Tap **OK**.
5. To adjust the focus of the image on the screen, in the Focus area, tap the left or right icons.
6. To adjust the image focus, in the Zoom area, tap the positive or negative icons.
7. To move the position of the image on the screen, in the Offset area, tap the forward, backward, left, or right arrow icons.
8. Tap **Save**.

Edit an existing ILS file

Changes made to an Intelligent Lens System (ILS) file are applied to all channels to which the ILS file has been applied.

1. Tap **Menu** > **Advanced Setup** > **ILS File Setup**.
2. Select an ILS file in the **Current ILS File** list.
3. To adjust the focus of the image on the screen, in the Focus area, tap the left or right icons.
4. To adjust the image focus, in the Zoom area, tap the positive or negative icons.
5. To move the position of the image on the screen, in the Offset area, tap the forward, backward, left, or right arrow icons.
6. Tap **Save**.

Enable automatic ILS adjustment on a channel

1. On the main screen of the TPC, in the Preferred Channels pane, tap a channel.
2. Tap **Lens Adjust**.
3. Select **Enable Automatic ILS**.

4. Tap **OK**.

Reset ILS file settings

You must reset the Intelligent Lens System (ILS) when you move the lens, you have manually adjusted horizontal or vertical offset, focus, or zoom, or when a power outage occurs during a channel change.

1. Tap **Menu** > **Advanced Setup** > **ILS File Setup**.
2. Select an ILS file in the **Current ILS File** list.
3. Tap **Quick Reset**.
4. Tap **Yes**.

Add a lens serial number

1. Tap **Menu** > **Advanced Setup** > **Lens Setup**.
2. Select a lens in the **Primary Lens** list.
3. In the **Serial Number** field, tap **Launch Dialog** .
4. Type the serial number for the lens.
5. Tap **Enter**.
6. Tap **Save**.

Enable automatic ILS on a lens

Use this procedure to move the lens to a position specified by the channel settings.

1. Tap **Menu** > **Advanced Setup** > **Lens Setup**.
2. Select a lens in the **Primary Lens** list.
3. Select **Enable Automatic ILS** in the **Intelligent Lens System** area.

Reset the lens position on projector startup

1. Tap **Menu** > **Advanced Setup** > **Lens Setup**.
2. Select a lens in the **Primary Lens** list.
3. In the Intelligent Lens System area, select **Reset on Startup**.

Complete a full lens calibration

1. Tap **Menu** > **Advanced Setup** > **Lens Setup**.
2. Select a lens in the **Primary Lens** list.
3. In the Intelligent Lens System area, tap **Full Calibration**.

4. Tap **Yes**.

Reset the ILS and the lens position

1. Tap **Menu > Advanced Setup > Lens Setup**.
2. Select a lens in the **Primary Lens** list.
3. In the Intelligent Lens System area, tap **Quick Reset**.
4. Tap **Yes**.

Work with the Scheduler

Use the scheduler to schedule when the projector turns on or off.

Schedule the projector to turn on or off

You need Administrator or Service permissions to complete this procedure.

1. Tap **Menu** > **Administrator Setup** > **Scheduler**.
2. Tap **Enable Scheduler**.
3. To view the available dates, tap and drag the scroll bar.
4. Tap a square below the date and next to the time that you want the projector to turn on or off.
5. Tap **New**.
6. To turn the projector off at a specific date and time, tap **Power Off**.
7. To turn the projector on at a specific date and time, tap **Power On**.
8. To enable or disable the scheduled event, tap **Start**.
New scheduled events are enabled by default.
9. Select a date and a time for the scheduled event.
10. To have the scheduled event occur weekly, tap **Weekly**.
11. Select the days that you want the event to occur.
12. To have the scheduled event occur once at a specific date and time, tap **Once**.
13. Tap **Expire** and select the date you want a weekly event to expire.
14. Tap **Save**.
15. To return to the calendar view, tap **OK**.

Edit a scheduled event

You need Administrator or Service permissions to complete this procedure.

1. Tap **Menu** > **Administrator Setup** > **Scheduler**.
2. To view the available dates, tap and drag the scroll bar.
3. Tap the event you want to edit.

4. Tap **Edit**.
5. Adjust the settings for the event.
6. Tap **Save**.
7. To return to the calendar view, tap **OK**.

Delete a scheduled event

You need Administrator or Service permissions to complete this procedure.

1. Tap **Menu > Administrator Setup > Scheduler**.
2. To view the available dates, tap and drag the scroll bar.
3. Tap the event you want to delete.
4. Tap **Delete**.
5. To return to the calendar view, tap **OK**.

Delete all scheduled events

You need Administrator or Service permissions to complete this procedure.

1. Tap **Menu > Administrator Setup > Scheduler**.
2. Tap **Delete All**.
3. Tap **Yes**.

Turn the scheduler off

You need Administrator or Service permissions to complete this procedure.

1. Tap **Administrator Setup > Scheduler**.
2. Tap to clear the **Enable Scheduler** checkbox.

View and Modify Projector Settings

Use the procedures in this section to modify projector settings including the touch panel controller, TPC screen brightness, and time settings.

Set projector and TPC preferences

You need Administrator or Service permissions to complete this procedure.

1. Tap **Menu > Administrator Setup > Preferences.**
2. Adjust these settings:

Field	Description
Temperature Units	Display temperature information in Celsius or Fahrenheit.
Image Orientation	The direction of the on screen image.
Beep on Screen Press	When selected, a sound plays when you tap the TPC screen.
Enable Screen Saver/Screen Saver Delay	Enables a screen saver and determines the frequency that the screen saver appears.
Over Temperature/Fan Failure	Opens an alarm window when a pre-defined event occurs.
Brightness	Adjusts the brightness of the touch screen display.
Calibrate Screen	Opens the Calibrate window and starts the TPC calibration.

Adjust projector time settings

You need Administrator or Service permissions to complete this procedure.

1. Tap **Menu > Administrator Setup > Time Setup.**
2. Adjust these settings:

Field	Description
Time Zone	The time zone where the projector is installed.

Field	Description
24 Hour Time	Displays time in a 24-hour format
Adjust for Daylight Savings Time	Automatically adjusts the time for daylight savings.
Time Offset	Adjusts the projector time.
Apply Time Adjustment	Applies the time adjustment setting.
Enable NTP	Turns Network Time Protocol (NTP) clock synchronization on.
NTP Server	The NTP server IP address.
Test NTP	Tests the NTP server settings.

Modify projector communication settings

You need Administrator or Service permissions to complete this procedure.

1. Tap **Menu** > **Administrator Setup** > **Communications Configuration**.
2. Complete these fields:



Field	Description
Device Name	The name of the projector.
IP Address	The IP address of the projector.
Subnet Mask	The subnet mask to which the address belongs.
Gateway	The IP address for the network gateway.
Apply	Applies Ethernet settings.
Serial Speed (Baud)	The baud rate of the serial port. The default is 115200.
Serial Access	Grants access to serial connections.
Ethernet Access	Grants access to Ethernet connections.
Enable	Enables SNMP.
V2 /V3	The SNMP protocol type. Contact Christie for the SNMP V3 user ID and password.
Management IP	The IP addresses where SNMP information and notifications are sent.
Download MIB to USB	Sends the SNMP Management Information Base (MIB) file to a USB flash drive.
Apply	Applies SNMP settings.

Add a network device

You need Administrator or Service permissions to complete this procedure.

1. Tap **Menu** > **Administrator Setup** > **Network Devices Setup**.
2. Tap the checkbox.

If the checkbox is not selected, the device does not appear in the **Network Devices** menu.

3. In the Device Name field, tap **Launch Dialog**  and type a name for the network device.
4. Tap **Enter**.
5. In the URL field, tap **Launch Dialog**  and type the URL for the network device.
6. Tap **Enter**.

Access a network device

1. Tap **Menu** > **Network Devices** > **Christie ACT**
2. To interact with the device in the top right corner of the window, tap  .

View the Microsoft Windows Task Manager

Use the Microsoft Windows Task Manager to view information about programs or processes running on your projector. The Task Manager also provides performance measures for processes.

1. Tap **Menu** > **Service Setup** > **System Access**.
2. Tap **Task Manager**.
3. Tap **OK**.

View the Microsoft Windows Computer Management console

Use the Microsoft Windows Computer Management console to manage local or remote computer settings.

1. Tap **Menu** > **Service Setup** > **System Access**.
2. Tap **Computer Management**.
3. Tap **OK**.

View Microsoft Windows Explorer

Microsoft Windows Explorer displays the hierarchical structure of files, folders, and drives on your projector.

1. Tap **Menu** > **Service Setup** > **System Access**.
2. Tap **Windows Explorer**.
3. Tap **OK**.

View the Microsoft Network Connections window

Use the Microsoft Network Connections to view and modify network connections.

1. Tap **Menu** > **Service Setup** > **System Access**.
2. Tap **Network Connections**.
3. Tap **OK**.

View projector information

The About window provides projector information including the serial number, the current software version, the Digital Light Processing (DLP) version, and the lens.

1. Tap **Menu** > **About**.

Record the lens serial number

1. Tap **Menu** > **Advanced Setup** > **Lens Setup**.
2. Select a lens type in the **Primary Lens** list.
3. Tap **Launch Dialog**  and type the lens serial number.
4. Tap **Enter**.
5. Tap **Save**.

Manage User Accounts

User access permissions

This table lists the Touch Panel Controller (TPC) permissions:

Permission	Description
Status	Can view basic projector status, diagnostic information and software version information. This is the default level for Serial Communication sessions.
Operator	Can activate channels and test patterns, view detailed diagnostic logs for in-depth troubleshooting and view server errors. This is the default level at the TPC.
Advanced	Can define all display setups such as source resolution, aspect ratio, image cropping, and color gamut information, optimize light output, and define setup files as selectable choices for processing a variety of incoming signals.
Administrator	Can perform screen Foot Lambert calibration, define Ethernet settings (IP network address), restore backup files, and upgrade the system software. Note: Administrators can add users and set user access rights from its own level and below only.
Service	Can access all windows on the TPC, except marriage.
Marriage	Can access all windows on the TPC, including marriage.

Add a user account

You need Administrator or Service permissions to complete this procedure.

1. Tap **Menu** > **Administrator Setup** > **User Accounts**.
2. Tap **Add**.
3. Tap **Launch Dialog**  in the **Username** field and type the user name.
4. Tap **Enter**.
5. Repeat steps 3 and 4 for the **Password** and **Confirm Password** fields.
6. Select access permissions for the user in the **Permissions** list.
7. Tap **Accept**.

Change a user account password or permissions

You need Administrator or Service permissions to complete this procedure.

1. Tap **Menu** > **Administrator Setup** > **User Accounts**.
2. Tap a user name in the **Username** list.
3. Tap **Edit**.
4. Change the password or the access permissions.
5. Tap **Accept**.

Delete a user account

You need Administrator or Service permissions to complete this procedure.

1. Tap **Menu** > **Administrator Setup** > **User Accounts**.
2. Tap a user name in the **Username** list.
3. Tap **Delete**.
4. Tap **Yes**.

Backup, Restore, and Upgrade Projector Files

Add an upgrade file

You need Administrator or Service permissions to complete this procedure.

1. Tap **Menu** > **Administrator Setup** > **Upgrade**.
2. Tap **Upload**.
3. Select the location of the upgrade file in the **Drive Letter** list.
4. Browse to the location of the upgrade file in the **Folder** list.
5. Tap the upgrade file and tap **Open**.

Remove an upgrade file

You need Administrator or Service permissions to complete this procedure.

1. Tap **Menu** > **Administrator Setup** > **Upgrade**.
2. Tap an upgrade file in the **Available Upgrade Files** list.
3. Tap **Remove**.

Install an upgrade

You need Administrator or Service permissions to complete this procedure.

1. Tap **Menu** > **Administrator Setup** > **Upgrade**.
2. Tap an upgrade file in the **Available Upgrade Files** list.
3. Tap **Next**.
4. Tap a component in the **Component** list.

5. Select one of these options:

Option	Description
Upgrade Different Components Only	Upgrades system components that are newer or older than the currently installed version.
ICP Only Force Install	Forces an ICP install regardless of what current version is installed.
Force Upgrade All	Upgrades all components in the upgrade package.
Factory Install	Removes all configurations and upgrades all components.

6. Tap **Next**.

Back up projector settings and information

You need Service permissions to complete this procedure.

1. Tap **Menu** > **Service Setup** > **File Management**.
2. Tap **Backup**.

Restore a file

You need Service permissions to complete this procedure. You can restore configuration, preference, channel, user, and ICP files.

1. Tap **Menu** > **Service Setup** > **File Management**.
2. To the right of the **File to restore** field, tap **Browse**.
3. Select the location of the upgrade file in the **Drive Letter** list.
4. Browse to the location of the upgrade file in the **Folder** list.
5. Tap the upgrade file and tap **Open**.
6. In the **Select type** list, select the type of file to restore.
7. Tap **Restore**.
8. Tap **Yes**.

Restore factory default settings

You need Service permissions to complete this procedure. You can restore configuration, reference, channel, and user files.

1. Tap **Menu** > **Service Setup** > **File Management**.
2. In the **Select type** list, select a file type to restore.
3. Tap **Reset Defaults**.

4. Tap **Yes**.

Move files to the projector

1. To move files from a USB Flash drive, insert the USB flash drive into the USB port on the side of the touch panel controller (TPC).
2. Tap **Menu** > **Service Setup** > **File Maintenance**.
3. Select a file type in the **File Type** list.
4. Tap and drag a file from the TPC Files pane to the Projector Files pane.

Delete projector files

1. Tap **Menu** > **Service Setup** > **File Maintenance**.
2. Select a file type in the **File Type** list.
3. Tap and drag a file from the **Projector Files** pane to the trash can icon.
4. Tap **Yes**.

Work with Test Patterns

Add or remove test patterns from the preferred test patterns pane

You need Administrator or Service permissions to complete this procedure.

1. Tap **Menu** > **Administrator Setup** > **Preferred Test Pattern Setup**.
2. To add a test pattern to the Preferred Test Pattern pane, tap and drag a test pattern from the **Unselected Patterns** list to **User Selected (Drag and Drop)** pane.
3. To remove a test pattern from the Preferred Test Pattern pane, tap and drag a test pattern from the **User Selected (Drag and Drop)** pane to the recycle bin in the bottom right corner.

Turn a test pattern on or off

1. In the task bar, tap the **Test Pattern**  .
2. Tap **All Test Patterns**.
3. Tap a test pattern in the Preferred Test Patterns pane to turn it on.
4. To turn the test pattern off, tap **Test Pattern Off**.

Display a full screen test pattern

1. In the task bar, tap **Test Pattern**  .
2. Tap **All Test Patterns**.
3. Double-tap a test pattern in the Preferred Test Patterns pane to turn it on.
4. Tap **Full Screen (Ignore screen file settings)**.

Add Devices

This section describes input connections and how to connect devices to the projector.

Play unencrypted content

1. To play unencrypted content, connect the projector to a device such as a computer, a Blu-ray player, or a game console with an HDMI to DVI connection.
2. To play audio content, connect the audio output cables to an audio processor.
See the documentation included with the device for detailed set up instructions.

Play encrypted content

1. To play encrypted cinema content, use the Integrated Media Block (IMB).
2. Connect the projector to a network-attached storage (NAS) or direct-attached storage (DAS) device.

Connect devices to the projector

This section provides information and procedures for connecting input devices to the projector. You connect input devices to the Projector Intelligence Board (PIB) located on side of the projector.

1. To access the communication ports, remove the access panel.
2. Route all cables along the channels located on the bottom of the projector and up through the opening in the frame to the communication connection port.
3. Replace the access panel to ensure server and source connections remain secure.

Projector connections and status LEDs

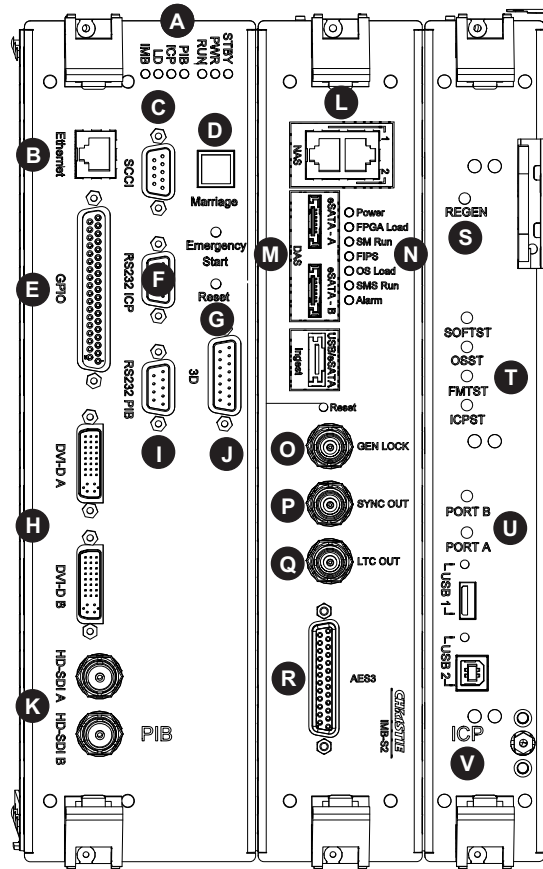

Item	Description
A	<ul style="list-style-type: none"> • STBY—The LED is green when the standby power supply is active. If the LED is not illuminated, the standby power supply has failed or the projector circuit breaker is off. • PWR—The LED is green when the Low Voltage Power Supply (LVPS) is active. If the LED is not illuminated, the LVPS has failed or the projector circuit breaker is off. • RUN—The LED flashes green when the projector is operating normally. If the LED is not illuminated or solid green, a communication, software, or hardware error has occurred. If the LED is yellow, the projector cannot communicate with the touch panel controller (TPC). • PIB—The LED is green when the Projector Intelligence Board (PIB) is detected and operating correctly. A red LED indicates a communication error. A flashing red LED indicates the PIB is not installed correctly. If the LED is not illuminated, the PIB is inactive. • ICP—The LED is green when the ICP is operating correctly. A red LED indicates a communication issue. If the LED is not illuminated, the ICP is inactive. • LD—The LED is green when the Link Decrypter (LD) is active. • IMB—The LED is green when the Integrated Media Block (IMB) is operating correctly. A red LED indicates a communication issue. If the LED is not illuminated, the IMB is inactive.
B	Connects the projector to a 10Base-T/100Base-TX Ethernet connection.
C	A Simple Contact Closure Interface (SCCI) port that uses a simple dry contact closure to open or close the douser.

Item	Description
D	Indicates marriage status. In full power mode, a green LED indicates that the projector is properly married and encrypted content can be displayed. A red LED indicates marriage is broken and encrypted content cannot be displayed.
E	Connects the projector to external input and output devices, such as the Christie ACT.
F	Connects the projector to a computer.
G	Resets the projector electronics. After restarting, the projector returns to its previous power mode.
H	Connects the projector to non-cinema video and graphics sources. These are single-link ports for single-link cables and connectors. The connectors can be used together as a twin-link DVI port.
I	Connects the projector to Christie or third-party automation equipment. Utilizes the Christie-proprietary protocol.
J	Connects the projector to 3D devices such as MasterImage or RealD.
K	Connects the projector to high-definition cinema sources. The connectors can be used together to deliver Dual Link HD-SDI following the SMPTE 372M standard.
L	Ethernet ports to connect network-attached storage (NAS) devices.
M	eSATA ports to connect direct attached storage (DAS) devices.
N	LED status indicators: <ul style="list-style-type: none"> • Power—The LED is green when the Christie IMB is on. • FPGA Load—The LED is green when all FPGAs are successfully loaded. • SM Run—The LED flashes green when the security manager (SM) is running correctly. • FIPS—The LED is green when the FIPS (Federal Information Processing Standards Publications) security status is operating correctly. If the LED is red, an error has occurred. Restart the Christie IMB. If the LED remains red, return the Christie IMB to Christie Digital. • OS Load—The LED is green when the Christie IMB has successfully loaded the screen management system (SMS) operating system. • SMS Run—The LED flashes green when the screen management system (SMS) is running correctly. • Alarm—The LED is green when the screen management system (SMS) is operating correctly.
O	Input for multi-projector playback (Christie IMB to Christie IMB only).
P	Output for multi-projector playback.
Q	LTC output.
R	AES3 port for digital audio output.
S	Indicates the status of the regulator. A solid blue LED indicates the regulator is enabled. If the LED is not illuminated, the regulator is not enabled.
T	<ul style="list-style-type: none"> • SOFTST (Software State)—Indicates the state of the software application running on the ICP. During normal operation, this LED blinks. During start up, the LED changes from off to blinking. • OSST (Operating System State)—Indicates the state of the ICP operating system. During normal operation, the LED is green. During start up, the LED changes from off to green. • FMTST (FMT FPGA State)—Indicates the state of the FMT FPGA. During normal operation, the LED is green. When the power is turned on, the LED turns green immediately. • ICPST (ICP FPGA State)—Indicates the configured state of the ICP FPGA. During normal operation, the LED is green. When the power is turned on, the LED turns green immediately.

Item	Description
U	<ul style="list-style-type: none"> • PORT B—Indicates the status of the USB port. A green LED indicates the port is active. If the LED is not illuminated, the port is inactive. • PORT A—Indicates the status of the USB port. A green LED indicates the port is active. If the LED is not illuminated, the port is inactive.
V	Indicates the status of the Integrated Cinema Processor (ICP). A green LED indicates the ICP is operating correctly. A red LED indicates a communication issue. If the LED is not illuminated, the ICP is inactive.

Connect the projector to a computer

Connect one end of an Ethernet or a RS232 cable to the Ethernet or the RS232 PIB port on the projector communications panel and the other end to your computer. To communicate with the projector, add the projector to the same network as the computer.

Connect devices to the GPIO port

The GPIO port is a 37-pin D-sub connector located on the PIB input panel. The port provides eight input and seven output signals for connecting external devices to the projector. To configure the pins on the connector, tap **Menu > Administrator Setup > GPIO Setup**.

Each available pairing of pins (\pm) is defined as an input or an output. Four inputs and three outputs are predefined. If you want the projector to respond to an incoming signal, configure a pin as an input. If you want an external device to respond to the projector as an output signal, configure a pin as an output.

PIN	Positive	Negative	Description
GPIN #1	Pin 1	Pin 20	3-D L/R Input Reference
GPIN #2	Pin 2	Pin 21	3-D L/R Display Reference
GPIN #3	Pin 3	Pin 22	Reserved
GPIN #4	Pin 4	Pin 23	Reserved
GPIN #5	Pin 5	Pin 24	Input
GPIN #6	Pin 6	Pin 25	Input
GPIN #7	Pin 7	Pin 26	Input
GPIN #8	Pin 8	Pin 27	Input
GPOUT #1	Pin 9	Pin 28	External 3-D L/R Output Reference
GPOUT #2	Pin 10	Pin 29	Reserved
GPOUT #3	Pin 11	Pin 30	Reserved
GPOUT #4	Pin 12	Pin 31	Output
GPOUT #5	Pin 13	Pin 32	Output
GPOUT #6	Pin 14	Pin 33	Output
GPOUT #7	Pin 15	Pin 34	Output
PROJ_GOOD	Pin 16	Pin 35	Projector Good

The following diagram shows how to wire a GPIO cable to a server or a 3D device.

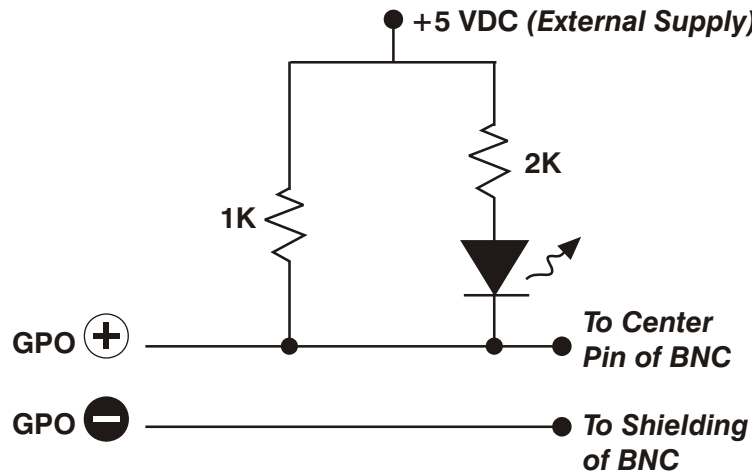

The recommended operating point is 5 mA, the maximum current is 50 mA, and the forward voltage drop is ~ 1 V (@ 5 mA).

Connect devices to the SCCI port

The Simple Contact Closure Port (SCCI) port is a DB-9 (male) connector located on the PIB input panel. The SCCI port controls a limited set of projector functionality through contact closures. This table lists the control functions available through the SCCI port:

PIN	Signal Name	Direction	Description
1	+5V standby	Out	Current limited 5VDC supply
2	Laser on	In	Projector power and lasers are on.
3	+5V standby	Out	Current limited 5VDC supply
4	Laser off	In	Projector power is on and laser are off.
5	+5V standby	Out	Current limited 5VDC supply
6	Douser closed	In	Close douser.
7	Douser open	In	Open douser.
8	Health output	Out	Playback stops and the open collector registers low when one of these interlocks is activated: <ul style="list-style-type: none"> • Tamper • Marriage Playback functions normally when the open collector registers high and all CineLink and laser interlocks are not activated.
9	Ground	Out	Ground

All SCCI inputs require a pulse input of 50ms to several seconds to operate reliably. Inputs are 5V resistor current limited LEDs inside of optocouplers.

The open-collector Health Output (PIN 8) circuit only draws power when a failure occurs or an interlock is activated.

Connect devices to the 3D terminal

The 3D Sync terminal is a 15-pin D-sub connector (female) located on the projector communications panel. This table lists the control functions available through the 3D connector.

PIN	Signal Name	Direction	Description
1	+12V	Out	Power to 3D device. Maximum 1A (total between both +12V pins).
2	GND	/	Ground
3	GND	/	Ground
4	RS232_RX	In	Data to projector from 3D device. 1200 Baud, 8 bits, no parity. Currently unsupported.
5	RS232_TX	Out	Data to projector from 3D device. 1200 Baud, 8 bits, no parity. Currently unsupported.
6	CONN_3D_MODE+	Out	SYNC from projector. To projector GPO collector. Compatible with current projector GPIO requirements and restrictions. (24VDC max, 50mA max) 3D ON = Hi logic level = O/P transistor ON 3D OFF = Low logic level = O/P transistor OFF
7	CONN_SYNC+	Out	SYNC from projector. To projector GPO collector. Compatible with current projector GPIO requirements and restrictions. (24VDC max, 50mA max)
8	3D_INPUT_REFRERENCE+	In	3D L/R Input Reference (P) (Voltage Limit: 2 VDC to 12VDC)
9	+12V	Out	Power to 3D system. Maximum 1A (Total between both +12V pins)
10	3D_INPUT_REFRERENCE-	In	3D L/R Input Reference (N) (Voltage limit: 1.4VDC to 12VDC)
11	3D_DISPLAY_REFERERENCE+	In	3D L/R Input Reference (P) (Voltage limit: 1.4VDC to 12VDC)
12	3D_DISPLAY_REFERERENCE-	In	3D L/R Input Reference (P) (Voltage limit: 1.4VDC to 12VDC)
13	CONN_3D_MODE-	Out	3D mode state from projector. From projector GPO emitter. Compatible with current projector GPIO requirements and restrictions. (24VDC max, 50mA max)
14	CONN_SYNC-	Out	SYNC from projector. From projector GPO emitter. Compatible with current projector GPIO requirements and restrictions. (24DC max, 50mA max)
15	Not connected		

View 3D Content

This section provides information and procedures for setting up and managing 3D presentations.

Hardware and software requirements

To display 3D images you require these items:

- A Christie CP42LH projector
- A 3D hardware system:
 - Pi-Cell polarizer for display on a screen that has a silver polarization-preserving surface for use with passive glasses (RealD)
 - Rotating polarizing wheel (external) with passive circular polarizing glasses (MasterImage); requires a silver screen
 - IR emitter for controlling the left eye/right eye gating (switching) of active glasses (Xpand)
 - Dual projector 3D—passive glasses (color separation); requires a white screen
- 6P 3D requires these items:
 - Two Christie CP42LH projectors
 - One laser rack containing LM-L-MP lasers (P/N: 000-104235-XX)
 - One laser rack containing LM-R-MP lasers (P/N: 000-104236-XX)
- A 3D connection cable
- Power supply for your synchronization output device. The 3D sync port can power output devices.
- Any 3D computer software application that supports 3D stereo on a supported computer(s) with associated graphic cards (suggested cards include AMD or NVIDIA)
- A video stream from a video source prepared to be sequential content (for Direct-Input 3D) or two video streams from a video source that has been prepared to be supplied left eye and right eye concurrently and frame locked (Dual-Input 3D)

Set up projectors for 3D

The projector is capable of displaying stereoscopic 3D video sources, relying on additional hardware (stereo emitters and glasses) to complete the display system.

Images generated from a stereo 3D video source consist of a series of images (frames) that alternate quickly between two slightly different viewpoints, corresponding to our left and right eyes. When these frames are displayed fast enough and viewed with special glasses synchronized to the left/right (L/R) changes, the resulting image appears with the same depth and perspective sense in the real world.

Stereo 3D applications require a stereo 3D-capable source, special hardware and software setups, and the projector's 3D Settings menu option to control the projector's processing, synchronization, and displaying of the stereoscopic 3D source material.

Active stereo 3D configuration

This diagram shows the typical hardware configuration for active stereo 3D systems:

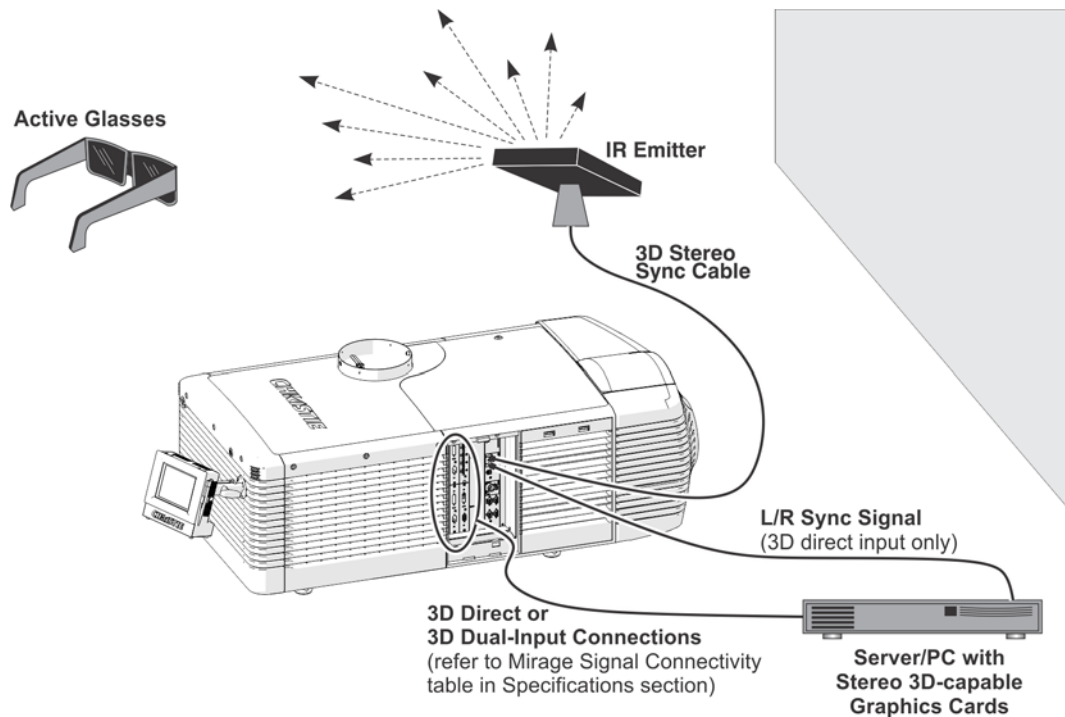

In response to the 3D Sync Out signal from the projector, the IR emitter emits an infrared signal to a receiver in the active 3D shutter glasses. This synchronizes the active glasses to alternatively open and close for the active stereo 3D applications.

Passive stereo 3D configuration

The following diagram shows the typical hardware configuration for passive stereo 3D systems:

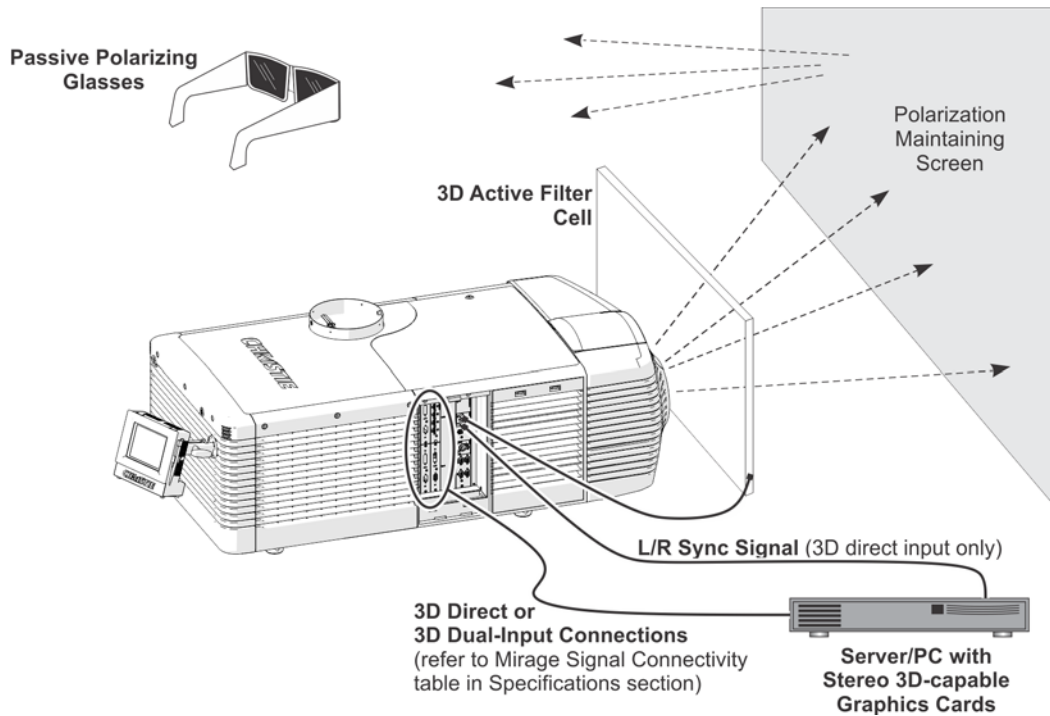

For operation with passive glasses, a 3D polarization filter is placed in front of the lens and is synchronized to the projected frames with the 3D Sync Out signal.

3D system timing

Consult the documentation for your glasses or polarization filter and keep their specifications in mind when configuring the projector for 3D operation. The projected video must be optimized for the glasses' shutter speed or polarization filter performance to prevent obvious "ghosting" of the video content (known as cross-talk in stereo 3D applications) or other more subtle color artifacts. Visual performance can be optimized by adjusting the Dark Interval and the 3D Sync Delay settings.

3D input video configurations

The stereo 3D input video stream may be supplied from the video server to the projector in two configurations: Direct-Input 3D or Dual-Input 3D.

Configuration	Description
Direct-Input 3D	<p>In this configuration a single video stream is provided by the video server, with the left eye and right eye frames supplied as alternate frames within the video stream. A 3D Input Sync may be used to identify the left eye frames.</p> <p>The Direct-Input 3D video stream may be supplied by either a Four-Port input video configuration (such as four cables each supplying one quadrant of the image) or an One-Port input video configuration (such as one cable supplying the entire frame).</p>
Dual-Input 3D	<p>In this configuration two video streams are provided by the video server, with the left eye supplied by one stream and the right eye supplied by the other. The video streams are frame locked and supplied concurrently.</p> <p>The Dual-Input 3D video streams may be supplied by either two Four-Port input video configurations (such as four cables each supplying one quadrant of the image for each eye, with a total of eight cables) or two One-Port input video configurations (such as one cable supplying the entire frame for each eye, with a total of two cables).</p>

3D sync terminal PIN map

The 3D Sync terminal is a 15-pin D-sub connector (female) located on the projector communications panel. This table lists the control functions available through the 3D connector.

PIN	Signal Name	Direction	Description
1	+12V	Out	Power to 3D device. Maximum 1A (total between both +12V pins).
2	GND	/	Ground
3	GND	/	Ground
4	RS232_RX	In	Data to projector from 3D device. 1200 Baud, 8 bits, no parity. Currently unsupported.
5	RS232_TX	Out	Data to projector from 3D device. 1200 Baud, 8 bits, no parity. Currently unsupported.
6	CONN_3D_MODE+	Out	<p>SYNC from projector. To projector GPO collector. Compatible with current projector GPIO requirements and restrictions. (24VDC max, 50mA max)</p> <p>3D ON = Hi logic level = O/P transistor ON</p> <p>3D OFF = Low logic level = O/P transistor OFF</p>
7	CONN_SYNC+	Out	<p>SYNC from projector. To projector GPO collector. Compatible with current projector GPIO requirements and restrictions. (24VDC max, 50mA max)</p>
8	3D_INPUT_REFRE NCE+	In	<p>3D L/R Input Reference (P)</p> <p>(Voltage Limit: 2 VDC to 12VDC)</p>

PIN	Signal Name	Direction	Description
9	+12V	Out	Power to 3D system. Maximum 1A (Total between both +12V pins)
10	3D_INPUT_REFRE NCE-	In	3D L/R Input Reference (N) (Voltage limit: 1.4VDC to 12VDC)
11	3D_DISPLAY_REFERE NCE+	In	3D L/R Input Reference (P) (Voltage limit: 1.4VDC to 12VDC)
12	3D_DISPLAY_REFERE NCE-	In	3D L/R Input Reference (P) (Voltage limit: 1.4VDC to 12VDC)
13	CONN_3D_MODE-	Out	3D mode state from projector. From projector GPO emitter. Compatible with current projector GPIO requirements and restrictions. (24VDC max, 50mA max)
14	CONN_SYNC-	Out	SYNC from projector. From projector GPO emitter. Compatible with current projector GPIO requirements and restrictions. (24DC max, 50mA max)
15	Not connected		

Hardware setup

Use an infrared emitter to control gating in active glasses, a polarizing Z-screen (Pi-cell) with passive glasses, or filter wheel with passive glasses.

	RealD Z-screen	RealD XL Box	Xpand	Master Image	Dual Projector
Installed/ Mounted Components	Z-screen mounted in front of the projection lens	XL box mounted in front of the projection lens	None	Wheel installed in front of the projector	Polarizing plates in front of lenses Two Christie CP42LH projectors 6P laser modules No silver screen 6P compatible glasses See the Chritise IMB User manual for complete set up instructions
Silver Screen	Yes	Yes	No	Yes	Yes
3D Glasses	Polarizing circular glasses	Polarizing circular glasses	Active glasses	Circular polarized glasses	Polarizing circular or linear glasses

Maintenance

This section provides information and procedures for performing maintenance. Read through this section in its entirety before performing maintenance activities. When performing maintenance, obey all warnings and precautions.



When accessing the restricted access location for projector service or maintenance, avoid exposure to the projector beam path:

- Power off the projector and disconnect from AC.
- Rotate the Beam Stop to **Closed**.

Failure to comply results in death or serious injury.



Failure to comply with the following could result in death or serious injury.

- Qualified technician is required for all installations.
- Never operate the projector without all of its covers in place.

Shut down for maintenance

Perform these steps before beginning any inspection or maintenance procedures on the projector.

1. If the projector is operating, turn it off.
2. Disconnect the projector from AC power.
3. Rotate the Beam Stop to **CLOSED**.
4. Remove the key from the Laser Rack Key switch.

Check the coolant level



The coolant must be refilled by a qualified service technician. Failure to comply could result in minor or moderate injury.

The liquid cooling system keeps the digital micromirror device (DMD) heat sinks cool. Check the coolant level every six months.

1. Remove the rear top cover.
2. Check the coolant level in the coolant reservoir.
3. If the coolant level is below the minimum level indicator, contact your Christie service technician to refill the coolant.

Inspect and clean optics



- Unnecessary cleaning of optics can increase the risk of degrading delicate coatings and surfaces. If you are not a qualified service technician, you can only inspect and clean the lens. Any other optical maintenance should be performed only by qualified service technicians.

Check these components periodically in a clean, dust-free environment using a high-intensity light source or flashlight. Clean them only when dust, dirt, oil, fingerprints, or other marks are obvious. Never touch an optical surface with bare hands. Always wear lint-free lab gloves.

The following tools are recommend for removing dust or grease:

- Powder free latex gloves
- Soft camel-hair brush
- Dust-free blower - air bulb or a canned air duster without additives such as Techspray 1671-10S Ultra-Pure Duster
- Lint-free lens tissue, such as Lensx 90 tissue or Newport Optics cleaning tissue
- Lens cleaning solution and a microfiber cloth (for the lens only)
- Isopropyl Alcohol Reagent Grade (ACS) 99.9%
- Acetone Reagent Grade (ACS)
- Optical grade cotton swabs with wooden stems
- Sticklers Fiber Optic Cleaner (can be used on all optical components)
- A bright, portable illumination device such as an LED flashlight

Remove dust from the projection lens

1. Brush most of the dust off with a camel-hair brush or use a dust-free blower.
2. Fold a microfiber cloth and wipe the remaining dust particles off the lens with the smooth portion of the cloth that has no folds or creases. Do not apply finger pressure. Instead, use the tension in the folded cloth to remove the dust.
3. If significant dust remains on the lens surface, dampen a clean microfiber cloth with lens cleaning solution and wipe gently until clean.

Remove fingerprints, smudges, or oil from the projection lens

1. Brush most of the dust off with a camelhair brush or use a dust-free blower.
2. Wrap a lens tissue around a swab and soak it in lens cleaning solution.
The tissue should be damp but not dripping.
3. Gently wipe the surface using a figure eight motion.
4. Repeat until the blemish is removed.

Replace the lens

Remove the lens

1. Shut down the projector, as described in [Shut down for maintenance](#) on page 68.
2. Attach a large lens cap to the front of the lens to avoid damage.
3. Release the lens locking lever (UP position).
4. Pull the lens straight out and attach a small lens cap to the rear of the lens to avoid damage.

Install a new lens

1. Make sure the lens locking lever is in the UP position.
2. If attached, remove the rear lens cap from the lens.
3. Slide the lens into the lens mount, aligning all connections. **NOTE:** *Always install the lens with "UP" label in the top position. This will assist in achieving consistent boresight alignment each time the lens is replaced.*
4. Secure the lens with the lens locking lever (DOWN position).
5. Calibrate the lens motors, as described below.

Calibrate the lens motors

If the lens motors are not calibrated properly, implications may include:

- Incorrect reporting of the lens motor position.
- Inability to use the full range of the lens motors.
- Lens motors traveling outside of the pre-defined keep-out area.
- Damage to the projector.

Reset and calibrate the lens motors when any of the following conditions are met:

- After a lens change.
- After the lens motors are physically moved using the manual adjustment knobs.
- After the projector is moved and/or jostled.
- After the lens motor IMCB has been replaced.

To calibrate the lens motors, tap **Lens > Calibrate Lens**.

Replace the lens

1. Shut down the system.
See [Shut down for maintenance](#) on page 68.
2. Remove the shroud.
See [Remove the shroud](#) on page 71.

3. Install a lens cap.
4. Turn the lens clamp to the open position on the motorized lens mount (MLM) (A).

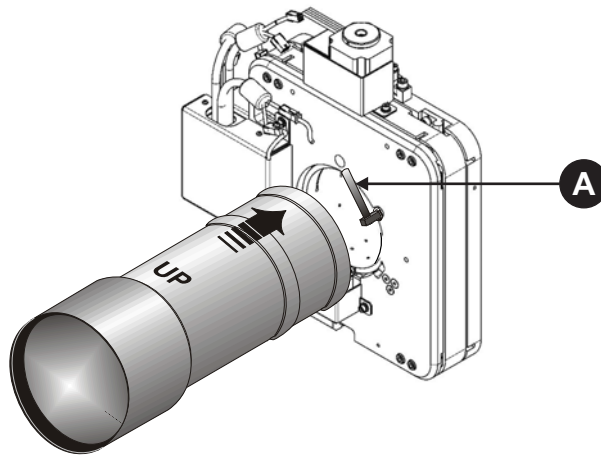

5. Pull the lens out of the lens mount and install a small lens cap on the rear of the lens.
6. Add the new lens.
See [Install the lens](#) on page 72.
7. To calibrate the lens motors, on the TPC tap **Menu > Configuration > Calibrate Lens Motors**.

Remove the shroud

1. Use finger pressure to push down on the shroud clips, as shown by the red arrows.

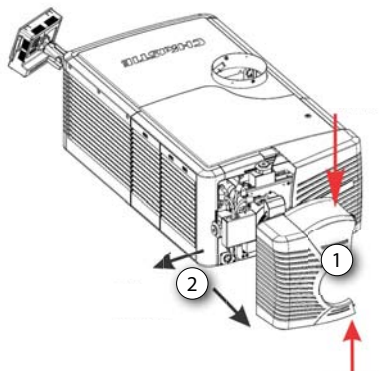

2. Carefully slide the shroud sideways and forward away from the lens mount, as shown by the black arrows.
3. Place the shroud on a clean surface to prevent scratches.

Install the lens



Keep fingers and other body parts away from the moving parts in the projector. Motors and fans may start without warning. Tie back long hair, remove jewelry and loose clothing before manually adjusting the projector. Failure to comply could result in minor or moderate injury.



Failure to comply may result in equipment damage.

- The lens seals the projection head, preventing contaminants from entering the main electronics area. Do not operate the projector without a lens installed. Attach a lens plug when installing or transporting the projector.
- Lens caps must be removed for operation or they can melt and damage the lens.

1. Unpack the zoom motor kit.
2. Use a flathead screwdriver to install the zoom motor mount onto the lens with a screw clamp (A).

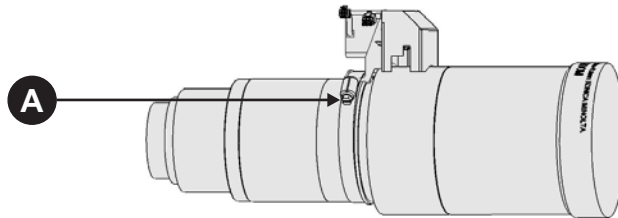

3. Remove the cover from the zoom motor mount with a #2 Phillips screwdriver. Keep the hardware and cover.

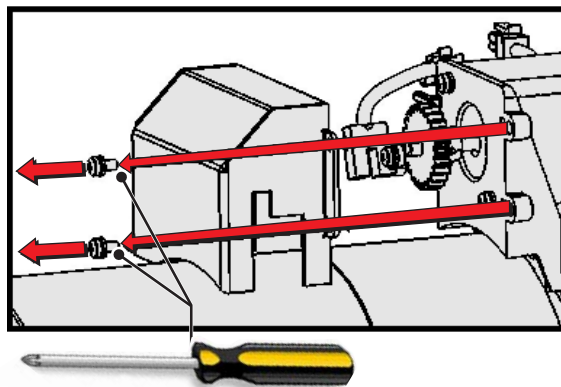

4. Install zoom gear ring and adapter onto the lens.

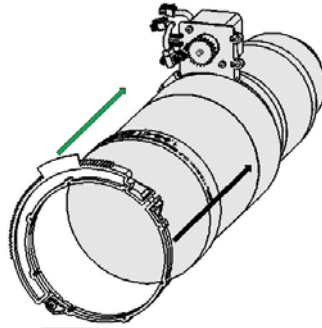

- Use a small adapter for lens 1.8–3.0 (2K) / 1.63–2.71 (4K).
- Use a large adapter for lens 1.45–2.05 (2K) / 1.31–1.85 (4K), 2.15–3.6 (2K) / 1.95–3.26 (4K), 1.25–1.83.1 (2K) / 1.13–1.66 (2K)
- All other lenses do not need an adapter.

5. Verify the placement of the following is correct.

- a. The flag is centered in the sensor (A).
- b. There is full travel of the gear ring (B).
- c. A gap between the gears prevents binding; if necessary, loosen the screws to adjust the gap, then tighten the screws to secure (B).

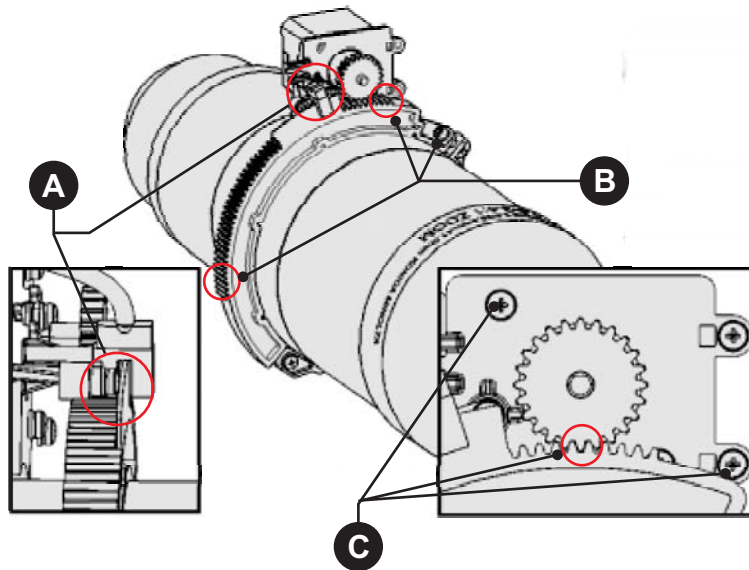

6. Turn the lens clamp to the open position on the MLM (A).

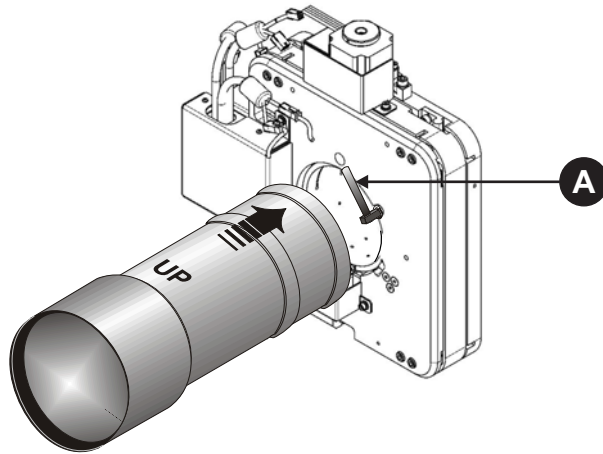

7. Fully insert the assemble into the lens mount opening without turning.
The lens is seated properly and the aperture is installed correctly when the lens is fully inserted.
8. Rotate the lens clamp downward to lock the lens assembly in place.

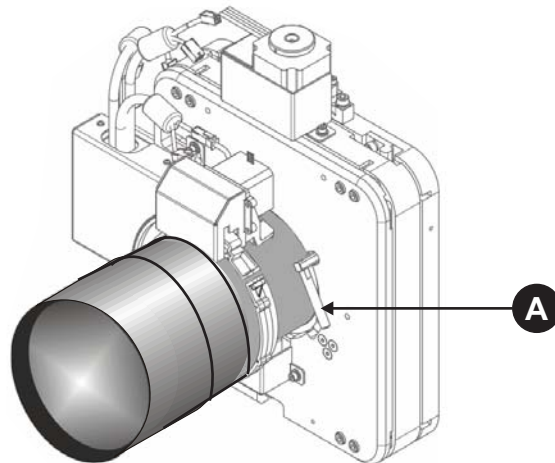

9. Install the cover with the screws (A), ensuring the cover is between the mounting tabs (B).

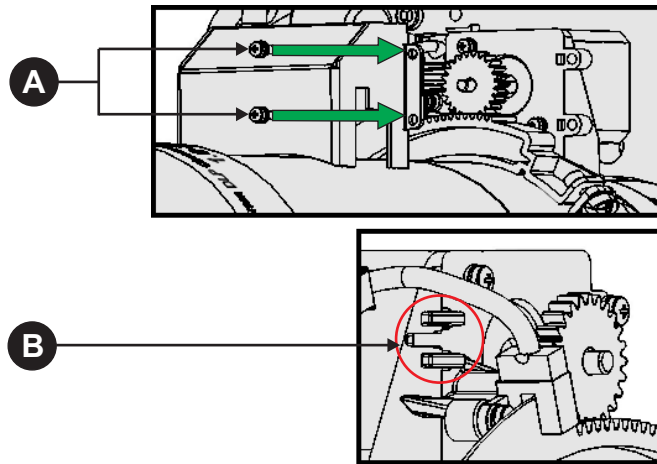

10. Connect the harness wires (A).

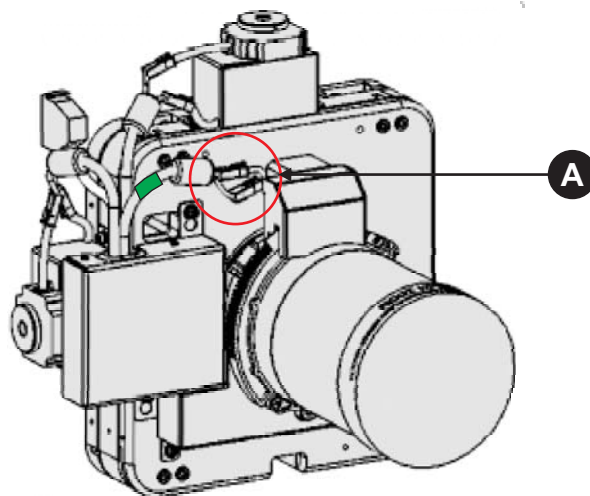

11. Install the shroud.

Filters



Use only high efficiency Christie approved filters. Never operate the projector without the filter installed. Never reuse an old paper air filter. Failure to comply may result in equipment damage.

Clean a washable filter

While used paper filters must be discarded, you can clean the blue electrostatic filters. If the amount of dirt on the filter is minimal, use a vacuum or compressed air to remove it. If you use

compressed air, the air must move through the filter in the opposite direction of the air flow indicator on the side of the filter.



The installation of a filter that has not been allowed to dry completely can cause an electrical short and damage the projector.

1. Hold the filter on an angle under warm running water so the water flows through the filter in the opposite direction of the air flow indicator on the side of the filter.
2. Rinse the filter thoroughly.
3. Submerge the filter for a minimum of 30 minutes in a container of warm water and two tablespoons of mild detergent or liquid dish soap.
If the filter is extremely dirty, move the filter from side to side occasionally, or remove the excess dirt by brushing both sides of the filter with a soft brush.
4. Rinse the filter thoroughly by holding it on an angle under cool running water. The air flow arrow on the side of the filter should face down.
5. Repeat steps 3 and 4 if the filter still appears dirty.
6. Shake the filter over a container until most of the water is removed.
7. Place the filter on its edge on a flat, stable surface and allow it to dry thoroughly for a minimum of 24 hours.
8. To confirm that the filter is dry, place it over a dry paper towel and shake it. If the paper towel remains dry, the filter can be installed in the projector.
9. Record the date the filter was cleaned.
10. Replace the filter following the instructions for the specific filter.

Replace the light engine air filter

This filter is located on the operator side near the front of the projector, behind the air filter cover.

1. Shut down the system.
See [Shut down for maintenance](#) on page 68.
2. On the air filter cover, push down on snap tab at top.
3. Tilt the top of the cover towards you and lift it up to remove.
4. Slide the air filter out and discard.

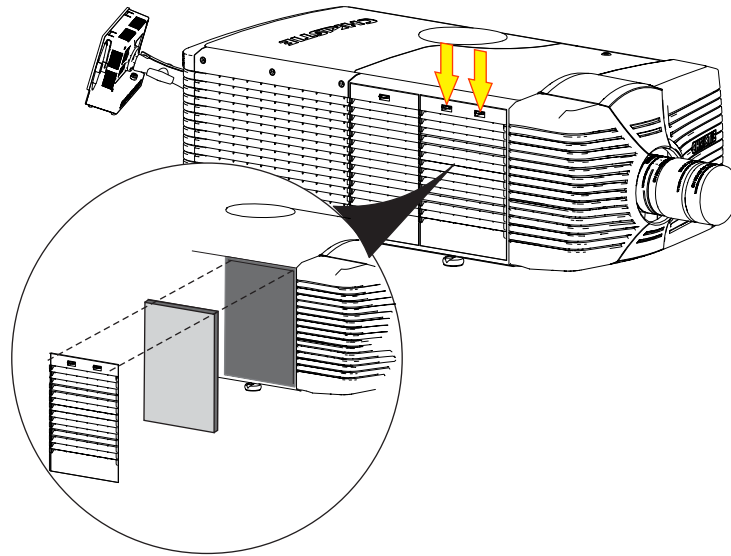

5. Install a clean air filter with the airflow indicator pointing toward the projector.
6. Replace the cover.

Clean the liquid cooling air filter

This filter is located on the operator side near the rear of the projector, behind a small air filter cover. The Liquid Cooling filter is an electrostatic reusable filter. Check the condition of this filter monthly.

1. Shut down the system.
See [Shut down for maintenance](#) on page 68.
2. Remove LVPS/liquid cooling cover.
3. Loosen the two screws (#2 Phillips) that secure the filter retaining bracket.

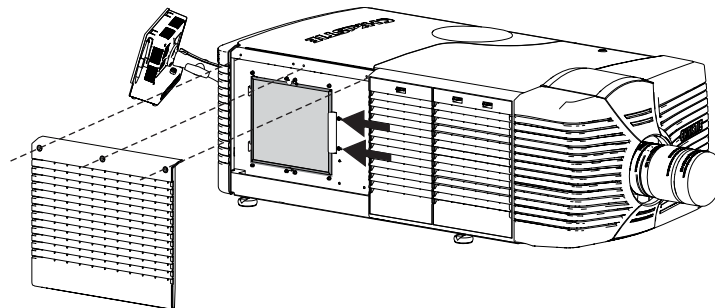

4. Slide the retaining bracket away from the filter.
5. Push downwards on the top of the filter so it clears the clip.
6. Pull the filter out and wash it.

See *Clean a washable filter* on page 75.

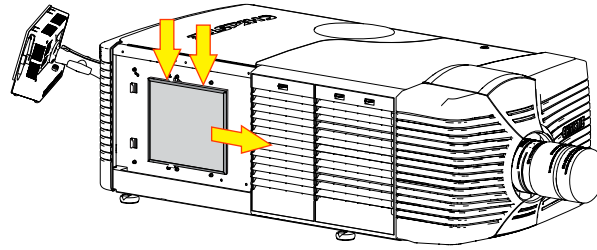

7. To replace the filter when dry, hold the air filter with the airflow indicator pointing toward the projector.
8. Tilt the lower end of the filter into the brackets.
9. Press downwards on the top of the filter frame, and release it under the top bracket.
10. Slide the retaining bracket left.
11. Tighten the two screws on the retaining bracket.
12. Install the LVPS/liquid cooling cover.

Replace the IOS filter

This filter is located on the front side of the projector, behind a small air filter cover.

1. Shut down the system.
See *Shut down for maintenance* on page 68.
2. Press down on snap tab to release filter cover.
3. Tilt and lift up to remove the cover.
The filter comes out with the cover.
4. Remove the filter from the cover and discard.

5. Install a clean air filter with the airflow indicator pointing toward the projector.

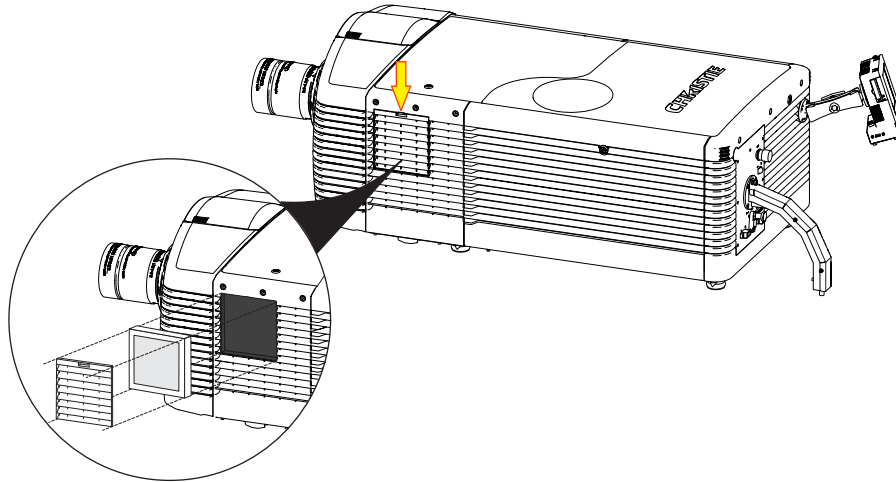

6. Replace the cover.

Clean the Laser Module filter

1. Shut down the system.

See [Shut down for maintenance](#) on page 68.

2. At the front of the Laser Module, tilt the top of the air filter toward you and lift out.

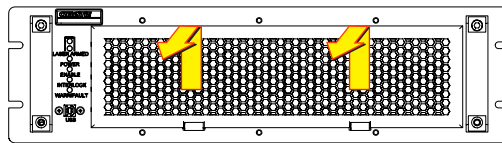

3. Pull the filter out and wash it.

See [Clean a washable filter](#) on page 75.

4. To replace the filter when dry, hold the air filter with the airflow indicator pointing toward the Laser Module.

5. Tilt the lower end of the filter into the bracket and attach to the Laser Module.

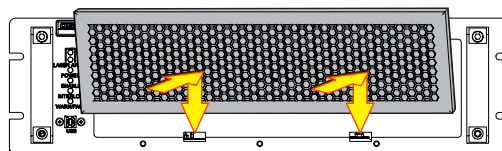

Troubleshooting

This section provides information and procedures for resolving common projector issues. If you cannot resolve a projector issue, contact Christie support. In order that a support representative can better assist you, have the model and serial number of your projector ready. For contact information see the back cover of this document.

Projector functionality

Issue	Resolution
Projector does not turn on	<ul style="list-style-type: none"> • Verify the power cord is connected to the projector and the AC power supply correctly. • Verify the touch panel controller (TPC) is on and the LEDs on the input panel are illuminated. If the TPC is off and there are no LEDs illuminated, verify the AC outlet to which the projector is connected is working and the TPC is connected to the projector. If the AC outlet is working and the TPC is connected to the projector, contact Christie support. • If the TPC is connected to the projector and the LEDs on the input panel are illuminated, on the TPC, verify in the Operational Status region of the Main panel does not indicate a PIB failure.
Touch panel controller	<ul style="list-style-type: none"> • Make sure the TPC is connected to the projector. • If the TPC fails to initialize, make sure the compact flash on the left side is installed correctly. • If the TPC fails to initialize, restart the projector. • If the location of button presses on the screen are not interpreted correctly, the TPC screen may need recalibrating. Tap Menu > Administrator Setup > Preferences. Tap Calibrate Screen and follow the on screen instructions.
Cannot establish communication with projector	Verify all input devices have the same subnet mask and gateway and unique IP addresses.
Projector does not move from standby to full power mode	<ul style="list-style-type: none"> • Check the touch panel controller (TPC) for error messages. • If a failure with PIB communications exists, reseal the board. • Check the Ethernet status LED on the rear of the TPC. • Verify that the internal fans are operating. • Look through the service panel and verify that the green LED is lit. This indicates the LVPS is operating. • Check all of the harness connections between LVPS and backplane. Pay particular attention to the small, white connector on the LVPS. • Replace the LVPS. • Check the interlocks. See Interlock cannot be reset on page 84.
DMD over-temperature warning	<ul style="list-style-type: none"> • In the left pane, tap Menu > Status > Temperatures. Verify if the DMD temperatures are too high. If the temperatures are too high, turn the lasers off and allow the cooling fans to cool the projector. • Check the condition of the air filters and clean or replace them if they appear to be dirty. • Verify that all fans are operating. • Ensure DMD coolant hoses are plugged in. • Ensure coolant level is full.

Display issues

Issue	Resolution
No image appears	<ul style="list-style-type: none"> • Make sure the lasers are armed. • Make sure the douser is open. • Make sure a white test pattern is selected. • Make sure the service doors are closed. • Verify the marriage icon on the main window of the touch panel controller (TPC) is green.
Flicker, shadows, or dimness	<ul style="list-style-type: none"> • Ensure the douser is open. • Fold mirror misalignment. Contact your Christie accredited service technician to resolve the issue. • Integrator rod misalignment. Contact your Christie accredited service technician to resolve the issue.
Blank screen, no display of cinema image	<ul style="list-style-type: none"> • Ensure the lens cap is not on either end of the lens. • Ensure the Laser Modules are armed. • Confirm all power connections are still OK. • Ensure the douser is open by verifying the state of the douser on Main panel. • Ensure any test pattern other than the full black test pattern displays properly. • Verify the correct display file is selected. • For cinema connections, verify the correct port is selected.
Severe motion artifacts	Verify if a synchronization problem exists with reversed 3-2 pull-down in the 60Hz-to-24Hz film-to digital conversion and correct it at the source.
Image appears vertically stretched or squeezed into the center of the screen	Open the Source File Setup window and verify the resolution and aspect ratio settings. Open the Screen File Setup window and verify the lens factor settings.
Inaccurate display colors	Tap Menu > Channel Setup . Tap Config 1 in the left pane and verify the correct value is selected in the PCF list. Tap Config 2 in the left pane and verify the correct value is selected in the Color Space field.
Display is not rectangular	<ul style="list-style-type: none"> • Verify the projector is level and the lens surface and screen are parallel to one another. • Tap Menu > Advanced Setup > Screen File Setup and verify the settings for the screen file are correct.
Display is noisy	<ul style="list-style-type: none"> • Verify the cables connecting the input device to the projector meet the minimum requirements and are undamaged. • Add signal amplification or conditioning if the distance between the input device and the projector exceeds 25 feet. • Turn the projector off and then on again.
Display has suddenly stopped	<ul style="list-style-type: none"> • Ensure the lasers were not turned off from the Laser Bank Manager. • Check the interlocks. See Interlock cannot be reset on page 84. • Turn off the projector and unplug the power cord from the power source. Plug the projector power cord into a power source and turn the projector on.

Issue	Resolution
The projector is on, but alternate content does not display	<ul style="list-style-type: none"> • Make sure the lens cover is removed from the lens. • Make sure the lasers are armed. • Make sure the douser is open. • On the main TPC screen, tap . • Tap Menu > Channel Setup. Verify the correct channel is selected and the settings are correct. • Ensure an active source is connected properly. Check the cable connections and make sure the alternative source is selected. • Verify you can select test patterns. If you can, check your source connections again.
The display is jittery or unstable	<ul style="list-style-type: none"> • Verify that the input device is connected properly. If the input device is not connected properly, the projector repeatedly attempts to display an image. • The horizontal or vertical scan frequency of the input signal may be out of range for the projector. • The sync signal may be inadequate. Correct the source problem.
Portions of the display are cut off	If you have resized the image, adjust the resizing settings until the entire image is visible and centered.
Inconsistent picture quality	Verify the quality of the signal from the input source.

Laser Module functionality

Issue	Resolution
Lasers fail to turn on	<ul style="list-style-type: none"> • If you have just turned on the projector, wait approximately five minutes for the Laser Modules to warm up and the lasers to arm. • Check the status of the interlocks. In the left pane, tap Menu > Status > Interlocks. If the status is Critical or Unknown, press Manual Reset on the projector to reset the interlocks. • Check the status of the Laser Bank Manager. In the left pane, tap Menu > Status > Laser Info. If the Laser Bank Manager Status in the right pane is not Online, ensure the Rack Switch is on and an Ethernet cable is attached from the Rack Switch to the TPC, to every Laser Module and to the Laser Bank Manager. Check the status of the Laser Modules on the Laser Bank Control Application.

Issue	Resolution
Interlock cannot be reset	<ul style="list-style-type: none">• If the projector is in standby, check the status of the RGB Sensor board. In the left pane, tap Menu > Status > RGB Sensor. If it is offline, press and hold the power button to put the projector in power on mode and press Manual Reset on the projector. Contact Christie support.• Make sure the wall breaker providing AC to the Laser Rack is on.• Make sure the Rack Switch in the Laser Rack is on.• Make sure the laser beam stop is in the open position.• Make sure the key switch on the Laser Rack is in the ON position.• Make sure the emergency stop buttons on the projector and the Laser Rack are released.• Make sure a fiber optic cable is properly attached to each Laser Module and to the projector.• Make sure the interlock cables to the Interlock In and Interlock Out connectors on each Laser Module are properly attached. Ensure the interlock cable is properly attached to the Laser Interlock connector on the projector.• Make sure one end the 25-pin interlock cable is properly attached to the interlock harness on the Laser Rack and the other end to the Laser Rack connector on the projector.
Interlock opens	<ul style="list-style-type: none">• Check the DMD temperatures. See DMD over-temperature warning on page 81.• Make sure that the lasers were not turned off from the Laser Bank Control Application.• Check the interlocks. See Interlock cannot be reset on page 84.

Projector Specifications

This section provides detailed specifications for the projector head.

Power requirements

Item	Description
Voltage	100 -240 VAC
Maximum Current	10 A
Line Frequency	50 - 60 Hz
Inrush Current	45 A maximum

Physical specifications

Item	Description
Size (L x W x H) (without front shroud)	(without lens mount, stack, and feet) 1097 mm (43.2 inches) x 644 mm (25.4 inches) x 432 mm (17.0 inches)
	(includes lens mount, stack, and feet) 1211 mm (47.7 inches) x 644 mm (25.4 inches) x 480 mm (19.0 inches)
	Shipping (includes skid) 1448 mm (57inches) x 914 mm (36 inches) x 711 mm (28 inches)
Size (L x W x H) (with front shroud)	(includes front shroud, stack, and feet) 1330 mm (52.4inches) x 644 mm (25.4 inches) x 480 mm (19.0 inches)
	Front shroud is shipped separately
Weight (without front shroud)	102 kg (224 pounds)
	Shipping (includes packaging) 133 kg (294 pounds)
Weight (with front shroud)	104 kg (230 pounds)
	Shipping (includes packaging) 136 kg (300 pounds)

Operating position

This diagram shows how the projection can be positioned.

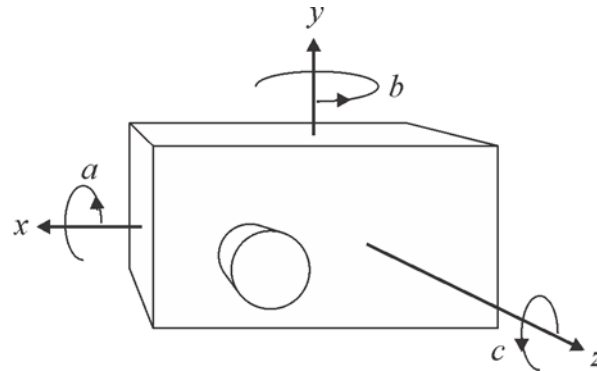

Angle	Range
a	-20 degrees to 20 degrees
b	360 degrees
c	-15 degrees to 15 degrees

Operating environment

Item	Description
Temperature	10 °C to 25 °C (50 °F to 77 °F)
Humidity (non-condensing)	20 % to 80 %

Non-operating environment

Item	Description
Temperature	-20 °C to 60 °C (-4 °F to 140 °F)
Humidity (non-condensing)	0 % to 95 %

Projection lens compatibility

Item	Description/Part Number
DLPCine High Brightness Prime Zoom Lens	<ul style="list-style-type: none"> • 1.25-1.45:1 (2K) / 1.13-1.31:1 (4K) (108-274101-xx) • 1.25-1.83:1 (2K) / 1.13-1.66:1 (4K) (108-342100-xx) • 1.45-1.8:1 (2K) / 1.31-1.63:1 (4K) (108-275101-xx) • 1.45-2.05:1 (2K) / 1.31-1.85:1 (4K) (108-335102-xx) • 1.45-2.1:1 (4K) (108-421108-xx) • 1.6-2.4:1 (2K) / 1.45-2.17:1 (4K) (108-336103-xx) • 1.8-2.4:1 (2K) / 1.63-2.17:1 (4K) (108-276101-xx) • 1.8-3.0:1 (2K) / 1.63-2.71:1 (4K) (108-337104-xx) • 2.15-3.6:1 (2K) / 1.95-3.26:1 (4K) (108-338105-xx) • 2.2-3.0:1 (2K) / 1.98-2.71:1 (4K) (108-277101-xx) • 3.0-4.3:1 (2K) / 2.71-3.89:1 (4K) (108-278101-xx) • 4.3-6.0:1 (2K) / 3.89-5.43:1 (4K) (108-279101-xx) • 5.5-8.5:1 (2K) / 4.98-7.69:1 (4K) (108-280101-xx)
DLPCine High Contrast Prime Zoom Lenses	<ul style="list-style-type: none"> • 1.25-1.83:1 (2K) / 1.13-1.66:1 (4K) (108-400105-01) • 1.45-2.05:1 (2K) / 1.31-1.85:1 (4K) (108-401106-01) • 1.6-2.4:1 (2K) / 1.45-2.17:1 (4K) (108-402107-01) • 1.8-3.0:1 (2K) / 1.63-2.71:1 (4K) (108-403108-01) • 2.15-3.6:1 (2K) / 1.95-3.26:1 (4K) (108-404109-01)

Accessories

Standard

- Touch panel controller with interface cable
- Installation and User Guides
- Interconnect diagram
- Front shroud
- Motors and zoom kit for motorized lens mount
- Lock down screws for lens mount

Optional

Item	Description/Part Number
Rack Stand	108-282101-xx
Bracket Foot Lock used with optional Rack Stand	116-100101-xx
Duo Stacking Frame	108-450100-xx
DuoAlign Kit	100-469100-xx
Right Arm Duo Assembly	108-449108-xx
Left Arm Duo Assembly	108-463104-xx
Mirror Duo Spare	108-476108-xx
Adjustable Rack Stand for Duo	108-416102-xx
DLP Cinema® Firmware Installation Program	Available online
TPC Remote Cable (30m)	003-111169-xx

Third-party accessories

- 3D Equipment

Replacement air filters

Item	Description/Part Number
LAD Filter	03-001982-5XP
Intake LE Filter	003-001184-XX
IOS Air Filter	003-003082-XX
Radiator Filter Washable	003-005009-XX

Laser Module Specifications

This section provides detailed specifications for Christie Laser Modules. Due to continuing research, specifications are subject to change without notice.

Power requirements.

Item	Description
Voltage	46 -53 VDC
Maximum Current	22 A

Physical specifications

Item	Description
Size (L x W x H)	3800 mm (31.5 inches) x 443 mm (17.5 inches) x 130 mm (5.25 inches)
	Shipping (includes packaging) 953 mm (37.5 inches) x 851 mm (33.5 inches) x 286 mm (11.25 inches)
Weight	32 kg (70 pounds)
	Shipping (includes packaging) 46 kg (100 pounds)
Operating Position	Tilt of projection axis from horizontal ± 30 degrees maximum

Operating environment

Item	Description
Temperature	10 °C to 25 °C (50 °F to 77 °F)
Humidity (non-condensing)	20% to 80%

Non-operating environment

Item	Description
Temperature	-25 °C to 65 °C (-13 °F to 149 °F)
Humidity (non-condensing)	0% to 95%

Accessories

Included

- Ethernet cable
- Interlock cables

Additional

- LM Rack (Full) P/N 146-110103-XX
- LM Rack (Half) P/N 146-104106-XX
- LM Rack (Full) Plenum P/N 146-109101-XX
- DC Power Harness
- Fiber Bundle
- Modular DC Power Supply

Optional

- Air Filters
- Replacement Fan Pack

LM Rack Specifications

This section provides detailed specifications for the LM Rack (Full) and LM Rack (Half).

Power requirements

One to four single phase circuits power the LM Rack (Full).

One to three single phase circuits power the LM Rack (Half).

Item	Description
Voltage	200 - 240 VAC
Maximum Current	24 A
Line Frequency	50 - 60 Hz

Two single phase circuits for the Rack Switch and the Laser Bank Manager.

Item	Description
Voltage	100 - 240 VAC
Maximum Current	15 A
Line Frequency	50 - 60 Hz

One to two single phase circuits for a NAS. The second AC input is for an optional backup source, such as an uninterruptible power supply (UPS).

Item	Description
Voltage	100 - 240 VAC
Maximum Current	15 A
Line Frequency	50 - 60 Hz

Physical specifications

LM Rack (Full)

Item	Description
Length	with front plenum removed 1081.6 mm (42.58 inches)
	with front plenum installed 1375.6 mm (54.16 inches)
Width	without side duct installed 644 mm (25.83 inches)
	with side duct installed 744.6 mm (29.31 inches)
Height	without top duct installed 2196.6 mm (86.48 inches)
	with top duct installed 2296.6 mm (90.42 inches)
	with fiber optic bundle routed through top 2546.6 mm (100.26 inches)
Weight	with front plenum installed 299.8 kg (661 pounds)
	with front plenum removed 263.0 kg (580 pounds)
	with front plenum and rear door removed 257.1 kg (547 pounds)



The optional earthquake kit adds 10 mm (0.39 inches) to the height.

LM Rack (Half)

Item	Description
Length	1081.6 mm (42.58 inches)
Width	without side duct installed 644 mm (25.83 inches)
	with side duct installed 744.6 mm (29.31 inches)

Item	Description
Height	without top duct installed 1529.8 mm (60.23 inches)
	with top duct installed 1629.8 mm (64.17 inches)
	with fiber optic bundle routed through top 1879.8 mm (74.01 inches)
Weight	204.1 kg (450 pounds)
	with rear door removed 193.7 kg (427 pounds)



The optional earthquake kit adds 10 mm (0.39 inches) to the height.

Operating environment

Item	Description
Temperature	10 °C to 25 °C (50 °F to 77 °F)
Humidity (non-condensing)	20% to 80%

Non-operating environment

Item	Description
Temperature	-25 °C to 65 °C (-13 °F to 149 °F)
Humidity (non-condensing)	0% to 95%

Regulatory

This product conforms to the following regulations related to product safety, environmental requirements and electromagnetic compatibility (EMC). Due to continuing research, specifications are subject to change without notice.

Safety

- CAN/CSA C22.2 No. 60950-1
- UL 60950-1
- IEC 60950-1
- EN60950

Laser safety

- IEC 60825-1 (2007)
- FDA CDRH CFR 1040.10
- FDA CDRH CFR 1040.11

Electro-magnetic compatibility

Item	Description
Emissions	<ul style="list-style-type: none">• FCC CFR47, Part 15, Subpart B, Class A - Unintentional Radiators• CAN ICES-3 (A) / NMB-3 (A)• CISPR 22/EN 55022 Class A - Information Technology Equipment
Immunity	CISPR 24/EN55024 EMC Requirements - Information Technology Equipment

Environmental

- EU Directive (2011/65/EU) on the restriction of the uses of certain hazardous substances (RoHS) in electrical and electronic equipment and the applicable official amendment(s).
- EU Regulation (EC) No. 1907/2006 on the registration, evaluation, authorization and restriction of chemicals (REACH) and the applicable official amendment(s).

- EU Directive (2012/19/EU) on waste and electrical and electronic equipment (WEEE) and the applicable official amendment(s).
- China Ministry of Information Industry Order No.39 (02/2006) on the control of pollution caused by electronic information products, hazardous substances concentration limits (SJ/T11363-2006), and the applicable product marking requirements (SJ/T11364-2006)

Certification

The product is designed to comply with the rules and regulations required for the product to be sold in various regional markets, including USA/Canada, EU, Australia/New Zealand, Kuwait, China, Korea, Japan, Mexico, Ukraine, Russia, India, South Africa, and Saudi Arabia.

Corporate offices

USA – Cypress
ph: 714-236-8610

Canada – Kitchener
ph: 519-744-8005

Consultant offices

Italy
ph: +39 (0) 2 9902 1161

Worldwide offices

Australia
ph: +61 (0) 7 3624 4888

Brazil
ph: +55 (11) 2548 4753

China (Beijing)
ph: +86 10 6561 0240

China (Shanghai)
ph: +86 21 6278 7708

Eastern Europe and
Russian Federation
ph: +36 (0) 1 47 48 100

France
ph: +33 (0) 1 41 21 44 04

Germany
ph: +49 2161 664540

India
ph: +91 (080) 6708 9999

Japan (Tokyo)
ph: 81 3 3599 7481

Korea (Seoul)
ph: +82 2 702 1601

Republic of South Africa
ph: +27 (0)11 510 0094

Singapore
ph: +65 6877-8737

Spain
ph: + 34 91 633 9990

United Arab Emirates
ph: +971 4 3206688

United Kingdom
ph: +44 (0) 118 977 8000