



Installation and Setup Guide

020-103244-04

# **CineLife+ 4K-RGB**

CP4415-RGB, CP4420-RGB

**CHRISTIE®**

## NOTICES

### COPYRIGHT AND TRADEMARKS

Copyright © 2021 Christie Digital Systems USA Inc. All rights reserved.

All brand names and product names are trademarks, registered trademarks or trade names of their respective holders.

### GENERAL

Every effort has been made to ensure accuracy, however in some cases changes in the products or availability could occur which may not be reflected in this document. Christie reserves the right to make changes to specifications at any time without notice. Performance specifications are typical, but may vary depending on conditions beyond Christie's control such as maintenance of the product in proper working conditions. Performance specifications are based on information available at the time of printing. Christie makes no warranty of any kind with regard to this material, including, but not limited to, implied warranties of fitness for a particular purpose. Christie will not be liable for errors contained herein or for incidental or consequential damages in connection with the performance or use of this material. Manufacturing facilities in Canada and China are ISO 9001 certified.

### Warranty

Products are warranted under Christie's standard limited warranty, the details of which are available at <https://www.christiedigital.com/help-center/warranties/> or by contacting your Christie dealer or Christie.

### PREVENTATIVE MAINTENANCE

Preventative maintenance is an important part of the continued and proper operation of your product. Failure to perform maintenance as required, and in accordance with the maintenance schedule specified by Christie, will void the warranty.

### REGULATORY

The product has been tested and found to comply with the limits for a Class A digital device, pursuant to Part 15 of the FCC Rules. These limits are designed to provide reasonable protection against harmful interference when the product is operated in a commercial environment. The product generates, uses, and can radiate radio frequency energy and, if not installed and used in accordance with the instruction manual, may cause harmful interference to radio communications. Operation of the product in a residential area is likely to cause harmful interference in which case the user will be required to correct the interference at the user's own expense. Changes or modifications not expressly approved by the party responsible for compliance could void the user's authority to operate the equipment

CAN ICES-3 (A) / NMB-3 (A)

이 기기는 업무용(A급)으로 전자파적합등록을 한 기기이오니 판매자 또는 사용자는 이점을 주의하시기 바라며, 가정 외의 지역에서 사용하는 것을 목적으로 합니다.

### ENVIRONMENTAL

The product is designed and manufactured with high-quality materials and components that can be recycled and reused. This symbol  means that electrical and electronic equipment, at their end-of-life, should be disposed of separately from regular waste. Please dispose of the product appropriately and according to local regulations. In the European Union, there are separate collection systems for used electrical and electronic products. Please help us to conserve the environment we live in!

# Content

<b>Safety precautions. . . . .</b>	<b>5</b>
General safety precautions. . . . .	5
Laser safety precautions. . . . .	5
AC power precautions. . . . .	6
Light intensity hazard distance. . . . .	6
Product labels. . . . .	10
General hazards. . . . .	10
Mandatory actions. . . . .	12
Electrical labels. . . . .	12
Additional hazard labels. . . . .	12
Laser labels. . . . .	12
<b>Introduction. . . . .</b>	<b>14</b>
Product documentation. . . . .	14
Related documentation. . . . .	15
Projector components (front). . . . .	15
Projector components (rear). . . . .	16
List of components. . . . .	16
Key features. . . . .	17
Contact your dealer. . . . .	17
Technical support. . . . .	17
<b>Installing and setting up. . . . .</b>	<b>18</b>
Site requirements. . . . .	18
Preparing the installation site. . . . .	18
Lifting and positioning the projector. . . . .	19
Connecting to power. . . . .	19
Connecting to an uninterruptible power supply. . . . .	23
Installing the lens. . . . .	24
Projector power modes. . . . .	26
Using the Remote UI. . . . .	26
Turning the projector on or off. . . . .	27
Logging on to the projector. . . . .	27
Turning the light source on or off. . . . .	27

Activating marriage. . . . .	28
Completing the installation checklist. . . . .	28
<b>Video Input panel. . . . .</b>	<b>29</b>
HDMI video source. . . . .	30
HDMI video formats. . . . .	30
SDI video source. . . . .	32
SDI video formats. . . . .	32
Integrated Media Block (IMB) video source. . . . .	37
Series 2 IMB video formats. . . . .	37
HDMI video source connection from an IMB. . . . .	40
SDI video source connection from an IMB. . . . .	40
<b>Using channels to set input signal parameters. . . . .</b>	<b>41</b>
<b>Managing the light source. . . . .</b>	<b>43</b>
Creating a new laser file for CP4415-RGB and CP4420-RGB. . . . .	43
Modifying an existing laser file. . . . .	44
Copying existing laser settings to a new file. . . . .	44
Deleting a laser file. . . . .	45
<b>Adjusting the image. . . . .</b>	<b>46</b>
Calibrating the Intelligent Lens System. . . . .	46
Correcting vignetting. . . . .	46
Adjusting tilt and leveling the projector. . . . .	46
Correcting keystone effect. . . . .	47
Displaying a test pattern. . . . .	48
Adjusting the integrator rod and fold mirror. . . . .	48
Adjusting the boresight. . . . .	51
Adjusting DMD convergence. . . . .	54
Correcting on-screen color. . . . .	55
<b>Regulatory. . . . .</b>	<b>56</b>
Safety. . . . .	56
Electro-magnetic compatibility. . . . .	56
Emissions. . . . .	56
Immunity. . . . .	56
Environmental. . . . .	57

# Safety precautions

Learn about the safety precautions related to the Christie CineLife+ 4K-RGB projector. This projector is intended for use in a cinema environment.

## General safety precautions

Read all safety and warning guidelines before installing or operating the projector.



**Warning!** If not avoided, the following could result in death or serious injury.

- TRIP OR FIRE HAZARD! Position all cables where they cannot contact hot surfaces, be pulled, be tripped over, or damaged by persons walking on or objects rolling over the cables.
- This product must be installed within a restricted access location not accessible by the general public.
- Only personnel who are trained on the precautions for the restricted access location can be granted entry to the area.
- Install the product so users and the audience cannot enter the restricted area at eye level.
- ELECTRICAL and BURN HAZARD! Use caution when accessing internal components.
- High leakage current present when connected to IT power systems.
- FIRE AND SHOCK HAZARD! Use only the attachments, accessories, tools, and replacement parts specified by Christie.
- FIRE HAZARD! Do not use a power cord, harness, or cable that appears damaged.
- A minimum of four people or appropriately rated lift equipment is required to safely lift, install, or move the product.
- Do not install or operate the projector in any position that does not meet the stated product specifications for alignment and orientation.



**Caution!** If not avoided, the following could result in minor or moderate injury.

- Only Christie qualified technicians are permitted to open product enclosures.

## Laser safety precautions

Read all safety and warning guidelines before operating the projector laser.



**Warning!** If not avoided, the following could result in death or serious injury.

- Do not operate the cinema projector without all of its covers in place.
- LASER RADIATION HAZARD! This projector has a built-in Class 4 laser module. Never attempt to disassemble or modify the laser module.
- Do not look directly into the lens when the light source is on. The extremely high brightness can cause permanent eye damage.
- Possible hazardous optical radiation emitted from this product. (Risk group 3)

## AC power precautions

Read all safety and warning guidelines before connecting to AC power.



**Warning!** If not avoided, the following could result in death or serious injury.

- SHOCK HAZARD! Only use the AC power cord provided with the product or recommended by Christie.
- FIRE AND SHOCK HAZARD! Do not attempt operation unless the power cord, power socket, and power plug meet the appropriate local rating standards.
- SHOCK HAZARD! Do not attempt operation if the AC supply is not within the specified voltage and current, as specified on the license label.
- SHOCK HAZARD! The optional UPS power cord must be inserted into an outlet with grounding.
- SHOCK HAZARD! Disconnect the product from AC before installing, moving, servicing, cleaning, removing components, or opening any enclosure.
- Install the product near an easily accessible AC receptacle.



**Caution!** If not avoided, the following could result in minor or moderate injury.

- FIRE HAZARD! Do not use a power cord, harness, or cable that appears damaged.
- FIRE OR SHOCK HAZARD! Do not overload power outlets and extension cords.
- SHOCK HAZARD! Power supply uses double pole/neutral fusing.

## Light intensity hazard distance

This projector has been classified as Risk Group 3 as per the IEC 62471-5:2015 standard due to possible hazardous optical and thermal radiation being emitted.



**Warning!** If not avoided, the following could result in serious injury.

- PERMANENT/TEMPORARY BLINDNESS HAZARD! No direct exposure to the beam must be permitted. Class 1 Laser Product - Risk Group 3 according to IEC 60825-1:2014 and IEC 62471-5:2015.
- PERMANENT/TEMPORARY BLINDNESS HAZARD! Operators must control access to the beam within the hazard distance or install the product at the height that prevents exposure of spectators' eyes within the hazard distance. The hazard zone must be no lower than 2.5 meters (US installations) or 2.0 meters (global installations) above any surface upon which any persons are permitted to stand and the horizontal clearance to the hazard zone must be a minimum 1.0 meters.
- EXTREME BRIGHTNESS! Do not place reflective objects in the product light path.

The following diagram and table show the zones for ocular and skin hazard distances:

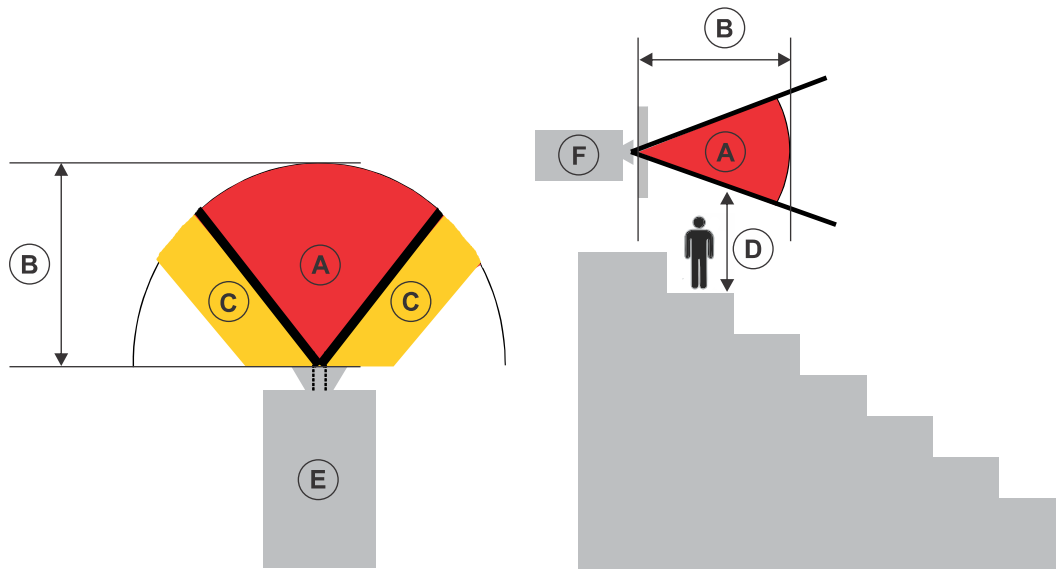

- A—Hazard zone. The region of space where the projection light from the laser-illuminated projector is above emission limits for Risk Group 2. The light intensity may cause eye damage after a momentary or brief exposure (before a person can avert his or her eyes away from the light source). The light may cause skin burns to occur.
- B—Hazard distance. Operators must control access to the beam within the hazard distance or install the product preventing potential exposure of the spectators' eyes from being in the hazard distance.
- C—No access zone. Horizontal clearance of the no access zone must be a minimum of 1.0 meters.
- D—Vertical distance to hazard zone. The hazard zone must be no lower than 2.5 meters (US installations) or 2.0 meters (global installations) above any surface upon which any persons are permitted to stand.
- E—Represents the top view of the projector.
- F—Represents the side view of the projector.

The following table lists the hazard distance for the Christie projector lens with the zoom adjusted to its most hazardous position.

Projection Lens (Throw Ratio 4K)	Part Number	CP4415-RGB	CP4420-RGB
0.90:1 HB fixed lens	38-809071-XX	1.0	1.0
1.13-1.66:1 DLPCine HB zoom lens	108-342100-XX	1.3	1.7
1.13-1.72:1 Enhanced DC 4K HB zoom lens	163-141107-XX	1.4	1.8
1.35-1.84:1 Enhanced DC 4K HB zoom lens	163-142108-XX	1.5	1.9
1.31-1.85:1 DLPCine HB zoom lens	108-335102-XX	1.5	1.9
1.45-2.10:1 Enhanced DC 4K HB zoom lens	163-143109-XX	1.7	2.2

<b>Projection Lens (Throw Ratio 4K)</b>	<b>Part Number</b>	<b>CP4415-RGB</b>	<b>CP4420-RGB</b>
1.45-2.17:1 DLPCine HB zoom lens	108-336103-XX	1.8	2.3
1.65-2.70:1 Enhanced DC 4K HB zoom lens	163-144100-XX	2.2	2.7
1.63-2.71:1 DLPCine HB zoom lens	108-337104-XX	2.2	2.7
1.95-3.26:1 DLPCine HB zoom lens	108-338105-XX	2.6	3.3
2.71-3.89:1 DLPCine HB zoom lens	108-278101-XX	3.1	3.9
3.89-5.43:1 DLPCine HB zoom lens	108-279101-XX	4.3	5.5
4.98-7.69:1 DLPCine HB zoom lens	108-280101-XX	6.2	7.8
1.13-1.66:1 DLPCine UHC zoom lens	163-103105-XX	1.2	1.5
1.13-1.72:1 Enhanced DC 4K UHC zoom lens	163-145101-XX	1.2	1.6
1.35-1.84:1 Enhanced DC 4K UHC zoom lens	163-146102-XX	1.3	1.7
1.31-1.85:1 DLPCine UHC zoom lens	163-104106-XX	1.3	1.7
1.45-2.10:1 Enhanced DC 4K UHC zoom lens	163-147103-XX	1.4	1.9
1.45-2.17:1 DLPCine UHC zoom lens	163-105107-XX	1.5	2.0
1.6 5-2.70:1 Enhanced DC 4K UHC zoom lens	163-148104-XX	1.8	2.3
1.63-2.71:1 DLPCine UHC zoom lens	163-106108-XX	1.8	2.3
1.95-3.26:1 DLPCine UHC zoom lens	163-107109-XX	2.2	2.9
2.71-3.89:1 DLPCine UHC zoom lens	163-108100-XX	2.6	3.4
3.89-5.43:1 DLPCine UHC zoom lens	163-109101-XX	3.7	4.8
4.98-7.69:1 DLPCine UHC zoom lens	163-110103-XX	5.3	6.8



**CP4415-RGB Hazard distance for HB and UHC lenses**

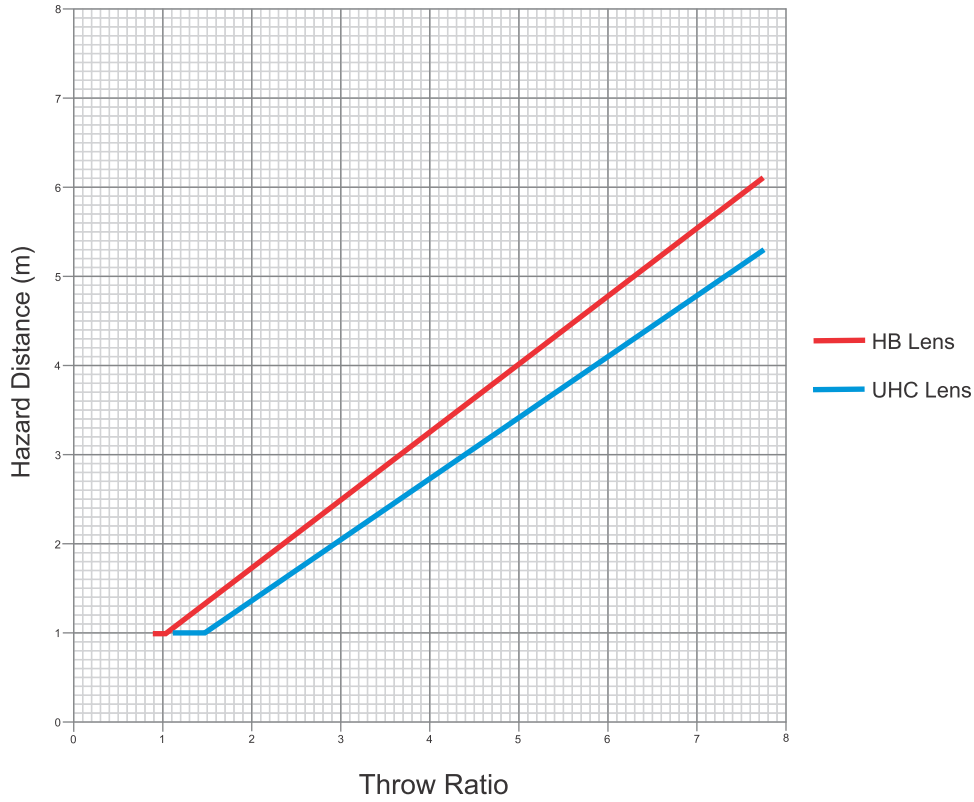

**CP4420-RGB Hazard distance for HB and UHC lenses**

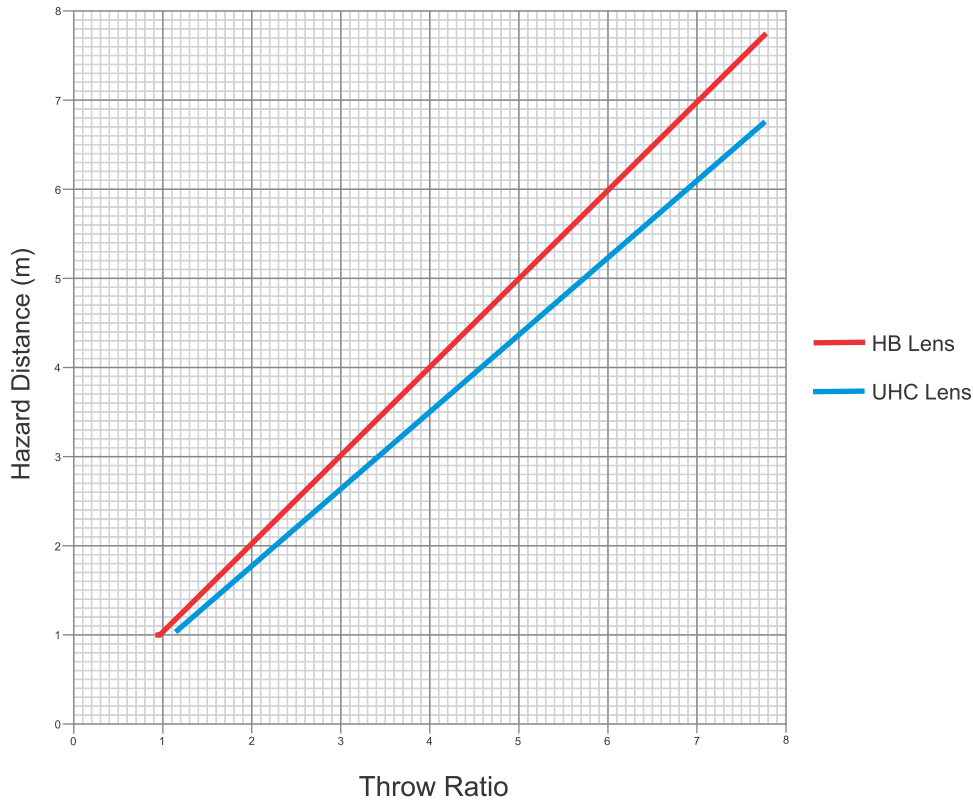

**For Installations in the United States**

The following must be in place for laser-illuminated projector installations in the United States:

- The projection room shall be clearly identified by the posting of laser warning and restricted access signs, and by restricting entry through physical means. The projection room sign must display the warning "No direct exposure to beam shall be permitted".
- The Christie Laser Projection System Installation Checklist must be fully completed after the installation and sent to [lasercompliance@christiedigital.com](mailto:lasercompliance@christiedigital.com). A copy can remain on-site. This checklist can be found as a separate document in the accessory box with the manual.
- Certain US states have additional laser regulatory requirements. Contact [lasercompliance@christiedigital.com](mailto:lasercompliance@christiedigital.com) for additional regulatory requirements.

**Product labels**

Learn about the labels that may be used on the product. Labels on your product may be yellow or black and white.

**General hazards**

Hazard warnings also apply to accessories once they are installed in a Christie product that is connected to power.

**Fire and Shock Hazard**

	<p>To prevent fire or shock hazards, do not expose this product to rain or moisture. Do not alter the power plug, overload the power outlet, or use it with extension cords. Do not remove the product enclosure. Only Christie qualified technicians are authorized to service the product.</p>
---	--

**Electrical Hazard**

	<p>Risk of electric shock. Do not remove the product enclosure. Only Christie qualified technicians are authorized to service the product.</p>
---	--



**Warning!** If not avoided, the following could result in death or serious injury.



Electric shock hazard. To avoid personal injury, disconnect all power sources before performing maintenance or service.



Electrocution hazard. To avoid personal injury, always disconnect all power sources before performing maintenance or service procedures.



Optical radiation hazard. To avoid personal injury, never look directly at the light source.



Voltage hazard. To avoid personal injury, always disconnect all power sources before performing maintenance or service procedures.



**Caution!** If not avoided, the following could result in minor or moderate injury.



General hazard.



Hot surface hazard. To avoid personal injury, allow the product to cool for the recommended cool down time before performing maintenance or service.



Burn hazard. To avoid personal injury, allow the product to cool for the recommended cool down time before performing maintenance or service.



Moving parts hazard. To avoid personal injury, keep hands clear and loose clothing tied back.



Fan hazard. To avoid personal injury, keep hands clear and loose clothing tied back. Always disconnect all power sources before performing maintenance or service procedures.



**Notice.** If not avoided, the following could result in property damage.



General hazard.



Not for household use.

## Mandatory actions



Consult the service manual.



Disconnect all power sources before performing maintenance or service procedures.

## Electrical labels



Indicates the presence of a protective earth ground.



Indicates the presence of an earth ground.

## Additional hazard labels



Indicates high leakage current. Earth or ground connection essential before connecting the power supply.



Indicates a light hazard. Do not look directly into the lens. The extreme high brightness can cause permanent eye damage.

## Laser labels

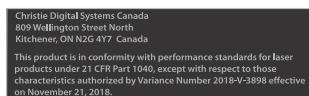

CP4415-RGB FDA laser variance (US projectors only)

This product is in conformity with performance standards for laser products under 21 CFR 1040, except with respect to those characteristics authorized by Variance Number 2018-V-3898 effective on November 21, 2018.

Christie Digital Systems Canada  
 809 Wellington Street North  
 Kitchener, ON N2G 4Y7 Canada  
 This product is in conformity with performance standards for laser products under 21 CFR Part 1040, except with respect to those characteristics authorized by Variance Number 2018-V-3898 effective on November 21, 2018.

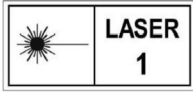

<p>IEC60825-1:2014 Class 1 Laser Product Risk Group 3</p> <p><b>Warning!</b> Do not look into the beam. No direct eye exposure to the beam is permitted. Not for household use. RG3 Hazard Distance. Refer to the manual.</p> <p><b>Avvertimento!</b> Ne regardez pas à l'intérieur du faisceau. L'exposition directe des yeux au faisceau est interdite. RG3 Distance à risque: Consultez le manuel.</p> <p><b>警告!</b> 请勿直视光束。不可让光束直射到眼睛。RG3 危害距离: 请参阅手册。</p> <p><b>警告!</b> ビームを見ないこと。ビームへの直接暴露は禁止されています。RG3 障害距離: 取扱説明書を参照。</p> <p>경고! 광선을 들어다보지 마십시오. 광선에 눈이 직접 노출되는 것은 허용되지 않습니다. RG3 위험 거리: 설명서 참조.</p>



CP4420-RGB FDA laser variance (US projectors only)

This product is in conformity with performance standards for laser products under 21 CFR 1040, except with respect to those characteristics authorized by Variance Number 2018-V-3898 effective on November 21, 2018.

CLASS 1 LASER PRODUCT IEC 60825-1:2014

CP4415-RGB wavelengths: 450 nm - 661 nm

CP4420-RGB wavelengths: 450 nm - 661 nm

Indicates a light hazard. Do not look directly into the lens. The extreme high brightness can cause permanent eye damage.

Class 1 Laser Product - Risk Group 3 according to IEC 60825-1:2014 and IEC 62471-5:2015

Indicates Class 4 laser radiation when open. Avoid eye or skin exposure to direct or scattered radiation.

# Introduction

This manual is intended for professionally trained operators of Christie high-brightness CineLife+ 4K-RGB projection systems.

Only trained Christie qualified technicians who are knowledgeable about the hazards associated with high-voltage, laser safety, and the high temperatures generated by the projector are authorized to assemble and install the projector. Only Christie qualified technicians are authorized to service the projector.

For complete production documentation and technical support, go to [www.christiedigital.com](http://www.christiedigital.com).

## Product documentation

For installation, setup, and user information, see the product documentation available on the Christie Digital Systems USA Inc. website. Read all instructions before using or servicing this product.

### CP4415-RGB

1. Access the documentation from the Christie website:
  - Go to this URL: <https://bit.ly/3iAQoZj> or <https://www.christiedigital.com/products/cinema/projection/cp4415-rgb>
  - Scan the QR code using a QR code reader app on a smartphone or tablet.



2. On the product page, switch to the **Downloads** tab.

### CP4420-RGB

1. Access the documentation from the Christie website:
  - Go to this URL: <https://bit.ly/3iBrYPu> or <https://www.christiedigital.com/products/cinema/projection/cp4420-rgb>
  - Scan the QR code using a QR code reader app on a smartphone or tablet.



- On the product page, switch to the **Downloads** tab.

## Related documentation

Additional information on the projector is available in the following documents.

- CineLife+ User Guide (P/N: 020-103073-XX)*
- CineLife+ 4K-RGB Product Safety Guide (P/N: 020-103243-XX)*
- CineLife+ 4K-RGB Service Guide (P/N: 020-103257-XX)*
- CineLife+ Serial Commands Guide (P/N: 020-103075-XX)*

## Projector components (front)

Learn about the components on the front of the projector.

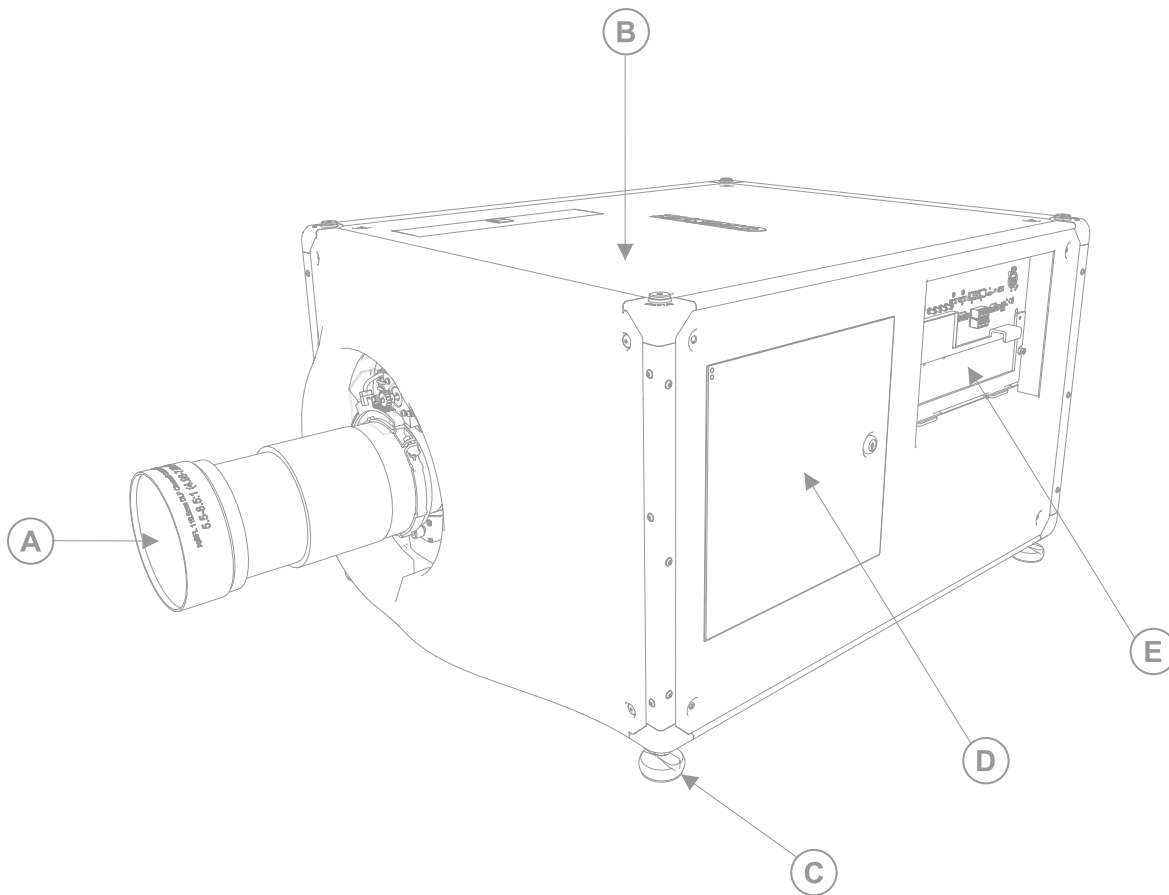

A	<p>Projector lens</p> <p>A list of available lenses is available in the projector specifications. For more information, see Index of parts and modules.</p>
B	<p>Top cover</p>

C	Adjustable feet Turn the adjustable feet to increase or decrease the projector height.
D	Service access door
E	Communications panel External devices are connected here.

## Projector components (rear)

Learn about the components on the rear of the projector.

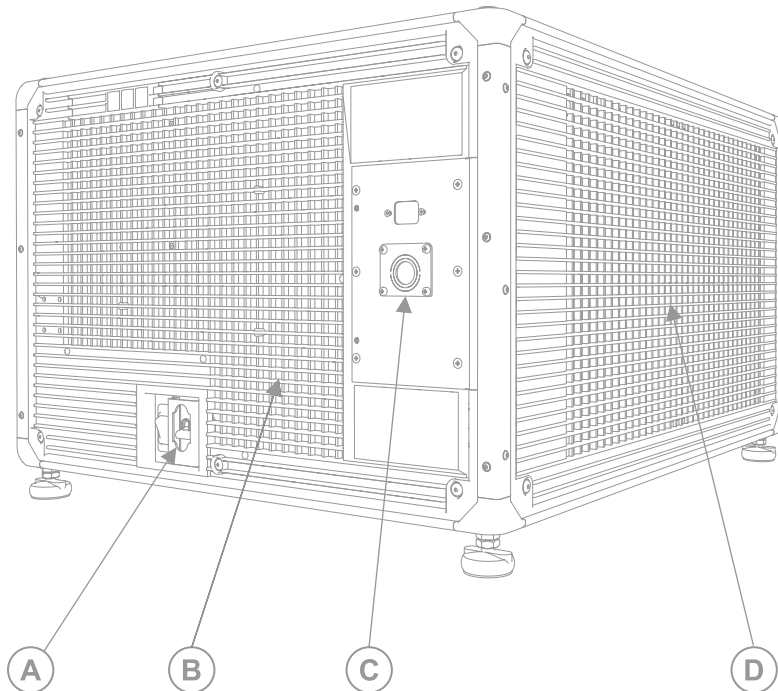

A	AC circuit breakers
B	Air exhaust
C	Power cord and AC receptacle
D	Air intake

## List of components

Verify that all components were received with the projector.

- High security key to open the projector service access door

Optional accessories such as an UPS inlet power cord or Touch Panel are also available. For information on available accessories, see *CineLife+ 4K-RGB Service Guide (P/N: 020-103257-XX)*.



## Key features

Understand the important features of the projector.

- Solid-state Christie ReaLaser™ RGB laser illumination
- Three-chip 1.38 inch 4K DLP™ light engine
- Christie CineLife™ Series 4 electronics
- LiteLOC™ color lock feature for constant image brightness and color
- Direct-coupled laser module integrated in the projector chassis
- Compact form to fit in existing projection booths
- Exhaust air extraction (using optional accessory)

## Contact your dealer

Record the information about your installation and keep this information with your records to assist with any servicing of your product. If you encounter a problem, contact your dealer.

Purchase record
Dealer:
Dealer or Christie Sales/Service contact phone number:
Serial number: The serial number can be found on the license label located on the display panel.
Purchase date:
Installation date:

## Technical support

Technical support for Christie Cinema products is available at:

- [Support.cinema@christiedigital.com](mailto:Support.cinema@christiedigital.com)
- +1-877-334-4267
- Christie Professional Services: +1-800-550-3061 or [NOC@christiedigital.com](mailto:NOC@christiedigital.com)

# Installing and setting up

Learn how to position and install the projector.

## Site requirements

To safely install and operate the CineLife+ 4K-RGB projectors, the installation location must meet these minimum requirements.

### Physical operating environment

- Ambient temperature (operating) 10°C to 35°C (50°F to 95°F)
- Humidity (non-condensing) 10% to 80%
- Operating altitude 0 to 3000 meters (0 to 9843 feet)

### External exhaust ducting

Sufficient ventilation is required around the projector to regulate the temperature of the internal laser module. If necessary, air intake and exhaust HVAC ducts can be installed.

An exhaust duct is also available for purchase as an optional accessory (P/N: 163-102104-XX). Instructions for installing the exhaust duct are included with the accessory part.

The installation site must provide an airflow 450 cubic feet per minute (CFM) at 1 to 1000 meters elevation, and must accommodate a heat load of 4 kW.



For each additional 1000 meters above sea level, increase the airflow (CFM) value by 15%. If an extraction duct is not used, the operating temperature range is restricted to 10°C to 25°C at a maximum altitude of 3000 meters.

### Permanent power connection

The projector must be connected to power using a hard-wired connection. The projector light source (main input) requires the permanent AC connection to operate. There is also an available connector for an uninterruptible power supply (UPS) to provide backup power for the projector electronics only. Certified wall breakers are required as part of the installation. Breakers must be part of the building and easily accessible. The size of the breaker is determined from the power requirements of the projector and can be up to 30A maximum for the main input and up to 20A maximum for the UPS input.

## Preparing the installation site

Ensure the installation area is ready for the components.

1. Clear the installation area.
2. Post laser hazard warning signs at all entry doors.

3. Place each component near its installation location.

## Lifting and positioning the projector

Safely lift and position the projector in the location where it will be used.



**Warning!** If not avoided, the following could result in death or serious injury.

- A minimum of four people or appropriately rated lift equipment is required to safely lift, install, or move the product.
- Do not install or operate the projector in any position that does not meet the stated product specifications for alignment and orientation.

This product must be installed in a landscape orientation, with all four feet supported on a level surface. Do not install or operate the projector in an inverted position. If your site has any installation requirements other than a typical theater projection booth, contact Christie for assistance.



Before lifting and positioning the projector, refer to the light intensity hazard distances.

1. Position each person at the corners of the projector.
2. Place both hands under the corner, grasping the projector frame.  
Do not lift the projector using any feature on the projector skin, such as the skin louvers or lens opening.
3. Lift up the projector and move it to the location where it will be used.
4. If you are installing the projector with the optional rack stand adapter (P/N: 163-101103-XX), follow the instructions provided with that accessory. For more information on available accessories, see the *CineLife+ 4K-RGB Service Guide (P/N: 020-103257-XX)*.
5. Position the projector so it is centered and parallel with the theater screen. If space is limited, aim the projector slightly off-center and use lens offset to center the image on the screen.

### Related information

*Light intensity hazard distance* (on page 6)

## Connecting to power

The recommended setup is to provide a hard-wired connection to AC power. When connecting the projector to AC power, follow all electrical codes for your location.

This product is suitable for connection to an IT power distribution system.



**Warning!** If not avoided, the following could result in death or serious injury.

- Always connect the ground or earth first to reduce shock hazard.
- FIRE HAZARD! Do not use a power cord, harness, or cable that appears damaged.
- FIRE AND SHOCK HAZARD! Do not attempt operation unless the power cord, power socket, and power plug meet the appropriate local rating standards.
- SHOCK HAZARD! Do not attempt operation if the AC supply is not within the specified voltage and current, as specified on the license label.
- SHOCK HAZARD! A dedicated, protected ground or earth wire must be installed on the product by Christie qualified technicians or electricians before it can be connected to power.
- A certified electrician must be present during installation to ensure the installation meets the local electrical code.



**Caution!** If not avoided, the following could result in minor or moderate injury.

- Use an appropriately sized strain relief connector with the knockout plate provided, to ensure adequate environmental sealing and to prevent the AC supply cable from accidentally being torn out or rubbing against the knockout plate.



- A 30 A maximum rated, certified wall circuit breaker is required. It must be part of the building and easily accessible.
- Use a minimum of 12 AWG copper wire, grounding included, for the connection of the main AC supply to the projector's ground lug.
- Either copper or aluminum is acceptable as conductor wiring material to the terminal block.

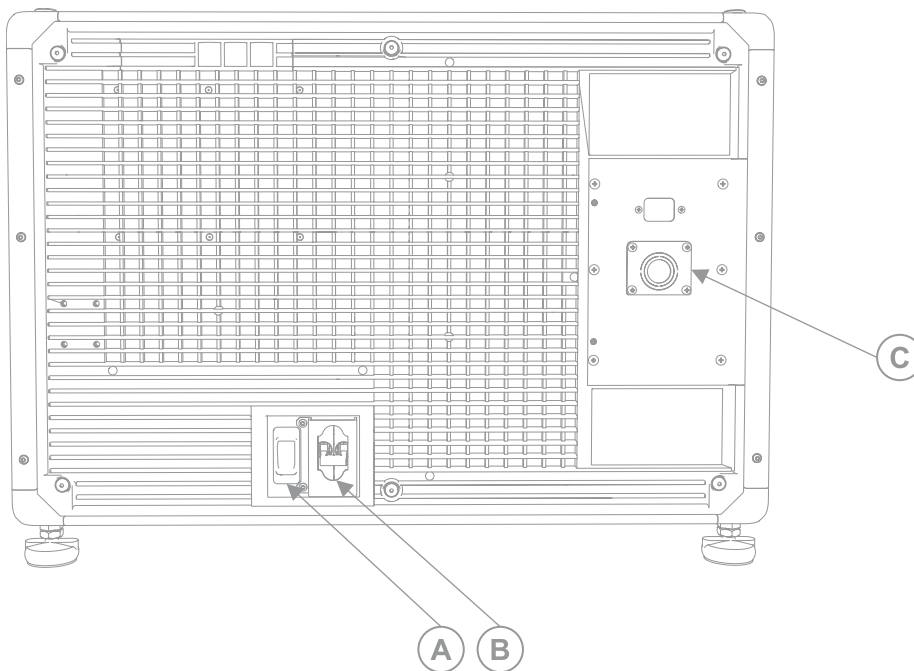

A	UPS circuit breaker
B	MAIN input circuit breaker
C	200-240 V main inlet

1. Remove the rear cover of the projector by unscrewing the six captive screws.

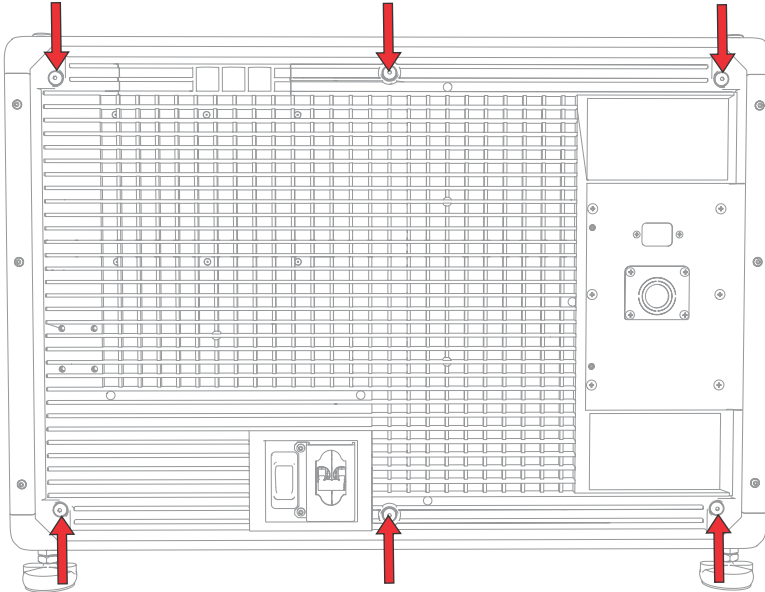

2. On the back right side of the projector, remove the four screws holding the AC receptacle knockout plate.  
The AC supply is routed to the terminal block through an appropriate strain relief mounted on this knockout plate.

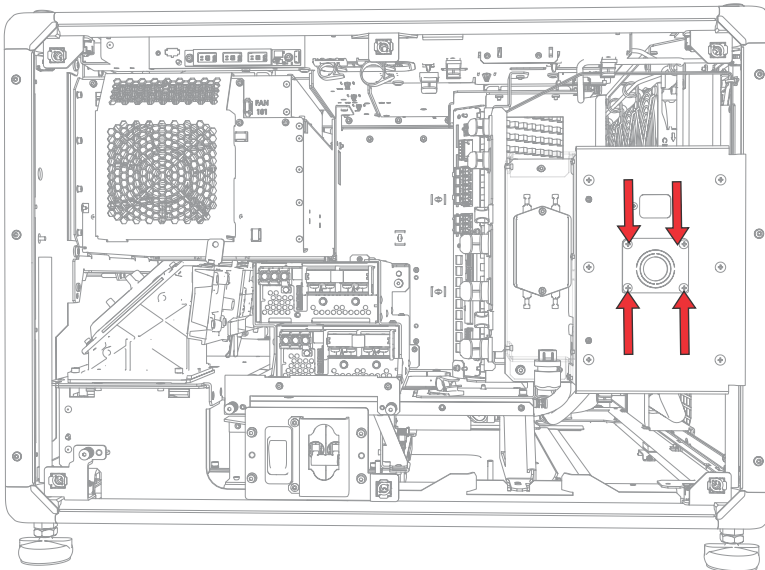

3. To open the AC input area of the projector, remove the six screws holding the cover and swing the cover downwards to open it.

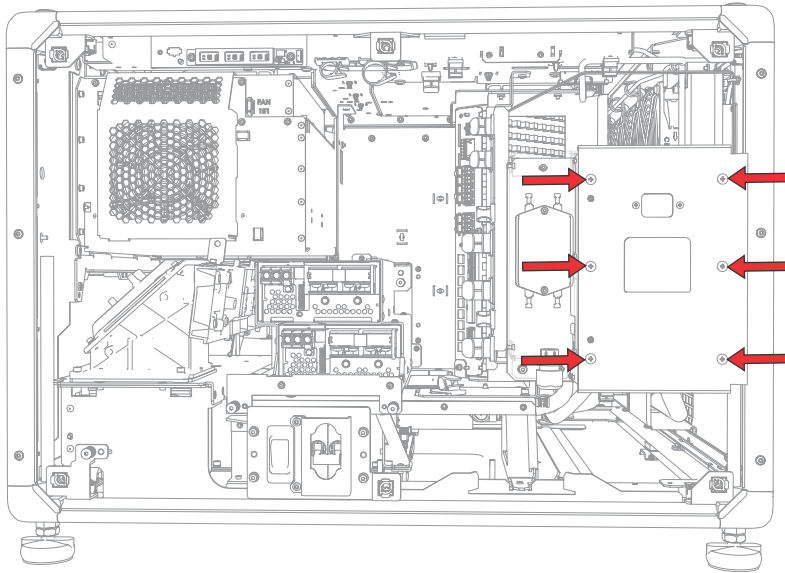

4. Taking the approved line cord for your location, strip the cable jacket to expose a 120 mm length of the bundled wires.
5. Cut the Line (black or brown) and Neutral (white or blue) wires to shorten them to a length between 80 to 100 mm.
6. Using a wire stripper, strip the insulation from each individual wire to expose 10 mm of bare wire on the end.
7. Pass the wires through the strain relief on the knockout plate and through the AC input cover.
8. Fasten the bare end of the wires into the Ground (G), Line (L), and Neutral (N) terminal block connectors, starting first with the Ground (green) connection, followed by the Line (black or brown) and Neutral (white or blue) connections.

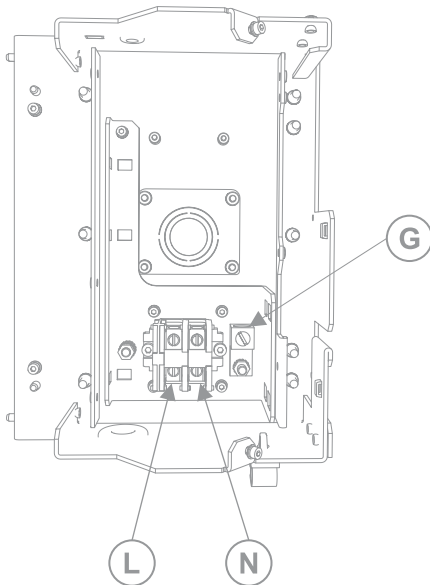

9. Lift the AC input cover into place and re-attach it using the six screws.

10. Using the four screws, re-attach the knockout plate and ensure the appropriate strain relief is in place.
11. Using the six captive screws, reinstall the rear cover of the projector.

## Connecting to an uninterruptible power supply

An uninterruptible power supply (UPS) allows the cinema projector head electronics to remain operable during a power failure.



**Warning!** If not avoided, the following could result in death or serious injury.

- SHOCK HAZARD! The optional UPS power cord must be inserted into an outlet with grounding.

The following table lists the part numbers for the optional UPS power cords for each region.

Power Cord Description	Part Number
North America 125V/15A	108-382104-XX
Japan 125V/12A	108-371102-XX
China 250V/10A	108-373104-XX
UK 250V/10A	108-388100-XX
EU/Korea 250V/10A	108-390103-XX
Australia 250V/10A	108-392105-XX
South Africa 250V/10A	108-487100-XX

1. If installed, remove the projector touch panel.
2. Remove the rear cover of the projector by unscrewing the 6 captive screws.
3. Behind the MAIN input circuit breaker, disconnect the MAIN input plug from the top power supply.

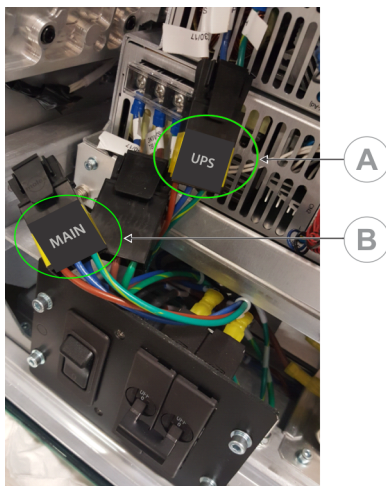

A	UPS input plug
B	MAIN input plug

4. Remove the protective cap from the UPS input plug.
5. Connect the UPS input plug to the top power supply (A).

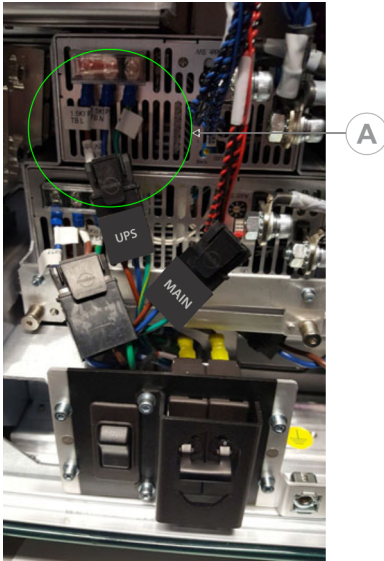

6. Place the protective cap from the UPS plug on the MAIN input plug.
7. Reinstall the rear panel of the projector.
8. Reinstall the projector touch panel.
9. Plug in the appropriate UPS power cord to the UPS and then into the UPS input (Input B) on the projector.

## Installing the lens

The lens seals the projection head, preventing contaminants from entering the main electronics area. Before installing the lens, ensure that you turn off the projector and the circuit breaker switches. Do not operate the projector without a lens installed. Install a lens plug when you install or transport the projector.

1. Remove the lens caps from the front and rear of the lens.



Lens caps must be removed or they can melt and damage the lens.

2. Position the lens so that the **UP** label is facing upward.



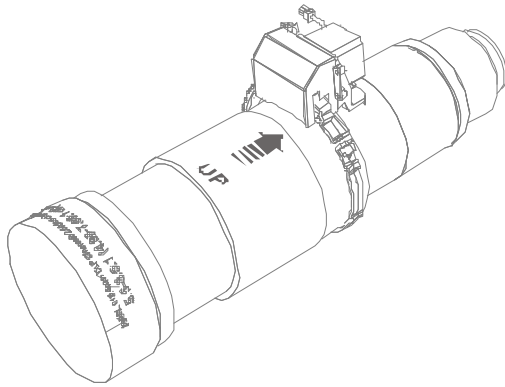

3. Turn the clamp on the lens mount to the open position.

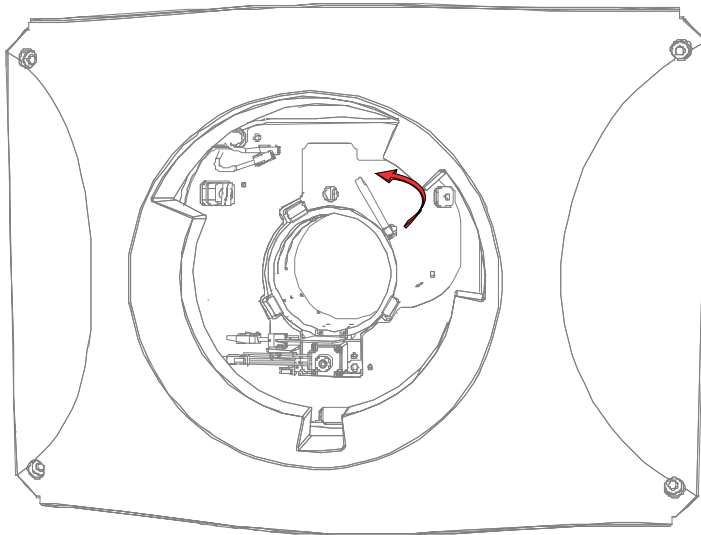

4. Fully insert the lens into the lens mount opening without turning, until it reaches the stop position.
5. Connect the lens zoom motor to the two zoom motor harness connectors.
6. Lock the lens assembly in place by rotating the lens clamp downward.

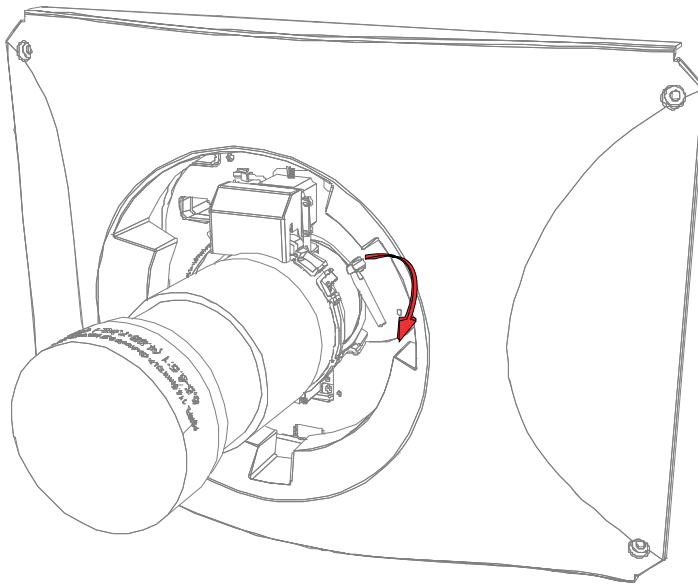

## Projector power modes

The CineLife+ 4K-RGB projectors track laser operation hours for the laser optical sub-system (LOS). The projector operates with the following power modes:

Mode	Description
Projector on	<ul style="list-style-type: none"> <li>• CineLife+ electronics and light engine are on</li> <li>• Laser optical sub-system (LOS) and thermo-electric cooler (TEC) devices are off</li> </ul>
Light source on	<ul style="list-style-type: none"> <li>• CineLife+ electronics and light engine are on</li> <li>• LOS and TEC are on</li> <li>• Fans run at full speed</li> </ul>
Standby	<ul style="list-style-type: none"> <li>• CineLife+ electronics remain on standby with the light engine off</li> <li>• LOS and TEC are off</li> <li>• Fans run at reduced speed</li> </ul>

## Using the Remote UI

Use the remote UI to access projector functionality.

1. Log into the Remote UI.
2. From the Remote UI default page, access the main projector user interface by clicking the **Projector Control** tab.
3. To upload and download files from the Projector, use the File Menu.

Examples of items that can be uploaded include:

- Projector Upgrade packages
- Backup packages to restore from
- Rental files to license the projector for Rental mode
- Test Patterns (PNG files only)
- Gamma files

Examples of items that can be downloaded include:

- Projector Backup files
  - Projector Certificates (required for content decryption)
  - Interrogator files (for support and troubleshooting)
4. If the projector has a GDC IMB SR-1000 installed and configured, you can access the GDC IMB Web UI by using the **Media Block** tab.

## Turning the projector on or off

Turn on the projector to display content, or turn off the projector to conserve energy or service the projector.



To operate the projector, the circuit breakers must be in the ON position. If you are servicing the projector or removing the protective covers, ensure that the MAIN and UPS circuit breakers are in the off position.

In the right toolbar, select and hold **Power**. 

If the light source is on when turning off the projector, the light source enters a ten-minute cool-down period automatically.

## Logging on to the projector

Log on to the projector to access projector menus.

1. Select **Login**.
2. In the User list, select a user name.
3. Enter your password.
4. Select **Login**.

## Turning the light source on or off

Turn the light source on to display content or view test patterns, turn the light off to extend the life of the lasers.

- To turn the light source on or off, in the right toolbar, select and hold **Light**. 

If you turn on the light source when the projector power is off, power is turned on automatically.

Allow the projector to cool down for 10 minutes after turning it off.

## Activating marriage

You must complete marriage to display content and to comply with the Digital Cinema Initiatives (DCI) specification.

For more information on marriage, refer to *CineLife+ User Guide (P/N: 020-103073-XX)*.

You cannot complete marriage remotely.

1. In the left navigation menu, select **Service Setup** > **Marriage Setup**.
2. Select **Start** and complete the Marriage Setup wizard.
3. Select **Finish**.
4. Verify that the marriage ring is installed correctly and an anti-tamper alarm does not appear on the touch panel.

## Completing the installation checklist

Complete the provided installation checklist (P/N: 020-103137-XX) and return it to Christie.

# Video Input panel

The Video Input panel, located on the projector side input panel (operator side), has a variety of ports that can supply alternative video content to the projector.

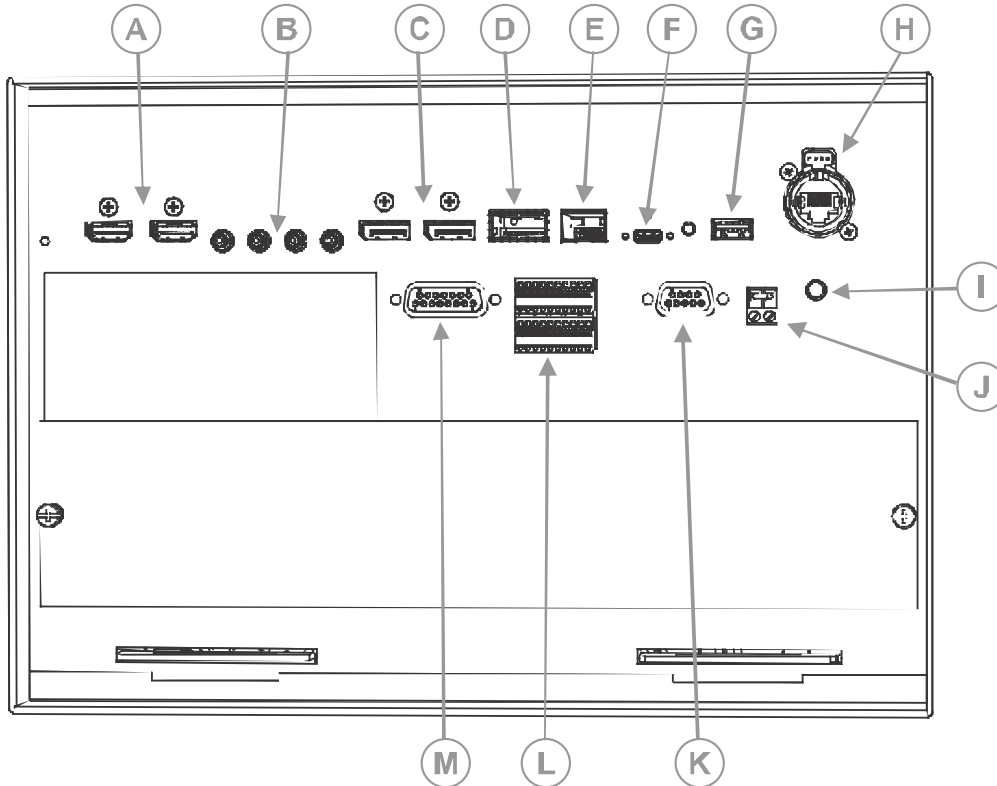

Connector ID	Port	Description
A	HDMI Input 1 and HDMI Input 2	Type A connector HDMI v2.0 protocol supporting EDID 1.3 with HDCP v1.4 and 2.2 support
B	SDI Input 1, SDI Input 2, SDI Input 3, and SDI Input 4	75 ohm Micro-BNC Connector Multi-Rate SDI in accordance with SMPTE ST 259 (270Mb/s), ST 292-1 (1.5Gb/s), ST 424 (3.0Gb/s), ST 2081-1 (6Gb/s) and ST 2082-1 (12Gb/s)
C	Display Port (DP1 and DP2)	
D	Christie Link port	
E	Software-Defined Video over Ethernet (SDVoE) port	
F	USB-C port	Connects the projector touch panel.

Connector ID	Port	Description
G	USB port	
H	Ethernet port	Connects to the local network and can send CineLife+ serial commands.
I	Marriage status LED indicator	In full power mode, a green LED indicates that the projector is properly married and encrypted content can be displayed. A red LED indicates marriage is broken and encrypted content cannot be displayed.
J	Fire alarm connection	
K	RS232 communication port	
L	GPIO port	Connects the projector to external automation or automation devices.
M	Connects the projector to 3D devices	

## HDMI video source

Plug the HDMI source directly into the Video Input panel.

**Table 1: Supported HDMI input configurations**

Input configuration	Description
Single-Input	Accepts connection of one HDMI cable. Supports both 2D and 3D frame-packed, top and bottom. In this configuration, the HDMI input supplies the entire video raster.

## HDMI video formats

The two HDMI inputs support the following image formats.

- 1920 x 1080 (HD)
- 3840 x 2160 (UHD)
- Fractional 1/1.001 frame rates.

### Single-Link 2D

Each HDMI input supports the following Single-Input (one cable) 2D 2K and 4K HDMI 2.0 image formats.

**Table 2: Single-Input 2D 2K and 4K HDMI 2.0 image formats**

Type	Format (Hres x Vres)	Frame rate (Hz)	Sampling	Bit-depth
2K	2048x1080	24, 25, 30, 50, 60, 120	Y'C <sub>B</sub> C <sub>R</sub> /RGB/4:4:4 Y'C <sub>B</sub> C <sub>R</sub> /4:2:2	8/10/12bpc

Type	Format (Hres x Vres)	Frame rate (Hz)	Sampling	Bit-depth
4K	4096x2160	24, 25, 30	Y'C <sub>B</sub> C <sub>R</sub> /RGB/4:4:4 Y'C <sub>B</sub> C <sub>R</sub> /4:2:2	8/10/12bpc
		50, 60	Y'C <sub>B</sub> C <sub>R</sub> /RGB/4:4:4	8bpc
		50, 60	Y'C <sub>B</sub> C <sub>R</sub> /4:2:2	8/10/12bpc

### Single-Link 2D: HD 720p and 1080i

Each HDMI input supports the following Single-Input (one cable) 2D HD HDMI 2.0 image formats.

Table 3: Single-Input 2D HD HDMI 2.0 image formats

Type	Format (Hres x Vres)	Frame rate	Sampling	Bit-depth	Notes
HD	1280x720	24, 25, 30, 50, 60	Y'C <sub>B</sub> C <sub>R</sub> /RGB/4:4:4 Y'C <sub>B</sub> C <sub>R</sub> /4:2:2	8/10/12bpc	-
	1920x1080i	25, 30	Y'C <sub>B</sub> C <sub>R</sub> /RGB/4:4:4 Y'C <sub>B</sub> C <sub>R</sub> /4:2:2	8/10/12bpc	2048x1080 interlaced (50/60 Hz field rate)

### Single-Input 2D: PC

Each HDMI input supports the following Single-Input (one cable) 2D HDMI 2.0 PC image formats.

Table 4: Single-Input 2D HDMI 2.0 PC image formats

Type	Format (Hres x Vres)	Frame rate (Hz)	Sampling	Bit-depth
PC	1280x800	60	RGB	8bpc
	1280x960	60	RGB	8bpc
	1280x1024	60	RGB	8bpc
	1440x900	60	RGB	8bpc
	1680x1050	60	RGB	8bpc
	1600x1200	60	RGB	8bpc
	2048x1200	60	RGB	8bpc

### Single-Input 3D: 2K / HD

Each HDMI input supports the following Single-Input (one cable) 3D 2K / HD HDMI 2.0 image formats.

Table 5: Single-Input 3D 2K / HD HDMI 2.0 image formats

Type	Format (Hres x Vres)	Frame rate (Hz)	Sampling	Bit-depth	Notes
3D	1280x720	50, 60	Y'C <sub>B</sub> C <sub>R</sub> /RGB/ 4:4:4 Y'C <sub>B</sub> C <sub>R</sub> /4:2:2	8/10/12bpc	Frame-packing / top-and-bottom
	2048x1080	24, 25, 30, 50, 60	Y'C <sub>B</sub> C <sub>R</sub> /RGB/ 4:4:4 Y'C <sub>B</sub> C <sub>R</sub> /4:2:2	8/10/12bpc	Frame-packing

## SDI video source

Plug the 12G, 6G, 3G, HD, or SDI source directly into the Video Input panel.

Table 6: Supported SDI input configurations

Input configuration	Description
Single-Link	Accepts connection of 12G, 6G, 3G, HD, and SD SDI input standards.
Dual-Link	Accepts connection of dual-link 6G, 3G, and HD SDI input standards.
Quad-Link	Accepts connection of quad-link 6G or 3G SDI input standards.

## SDI video formats

Each of the SDI inputs supports the following Single-Link 2D SD and HD image formats, Single-Link 2D HD and UHD/4K image formats, Dual-link 2D SDI image formats, and Quad-link 2D image formats.

- 1920 x 1080 (HD)
- 3840 x 2160 (UHD)
- Fractional 1/1.001 frame rates.

### Single-Link 2D: SD, 720p and 1080i

Each of the SDI inputs supports the following Single-Link (one cable) 2D SD, 720p, and 1080i image formats.

Table 7: Single-Link 2D SD, 720p and 1080i image formats

Type	Format (Hres x Vres)	Frame rate (Hz)	Sampling	Bit-depth	Notes
SD	720x480	30	Y'C <sub>B</sub> C <sub>R</sub> /4:2:2	10bpc	SD interlaced component at 270Mb/s (ST 259 level C)



Type	Format (Hres x Vres)	Frame rate (Hz)	Sampling	Bit-depth	Notes
					Interlaced (60 Hz field rate)
	720x576	25	Y'C <sub>B</sub> C <sub>R</sub> /4:2:2	10bpc	SD interlaced component at 270Mb/s (ST 259 level C) Interlaced (50 Hz field rate)
HD	1280x720	24, 25, 30, 50, 60	Y'C <sub>B</sub> C <sub>R</sub> /4:2:2	10bpc	HD 720p Y'C <sub>B</sub> C <sub>R</sub> component at 1.5Gb/s (ST 292-1)
	1280x720	24, 25, 30, 50, 60	Y'C <sub>B</sub> C <sub>R</sub> /4:4:4(4)	10bpc	HD 720p Y'C <sub>B</sub> C <sub>R</sub> /RGB component at 3.0Gb/s (ST 425-1) level A
2K	2048x1080	25, 30	Y'C <sub>B</sub> C <sub>R</sub> /4:2:2	10bpc	HD 1080i component at 1.5Gb/s (ST 292-1) Interlaced (50/60 Hz field rate)

### Single-Link 2D: 2K and 4K (HD / UHD)

Each of the SDI inputs supports the following Single-Link (one cable) 2D HD and UHD/4K image formats.

Table 8: Single-Link 2D HD and UHD/4K image formats

Type	Format (Hres x Vres)	Frame rate (Hz)	Sampling	Bit-depth	Notes
2K	2048x1080	24, 25, 30	Y'C <sub>B</sub> C <sub>R</sub> /4:2:2	10bpc	HD 1080p component at 1.5Gb/s (ST 292-1)
		48, 50, 60	Y'C <sub>B</sub> C <sub>R</sub> /4:2:2	10bpc	HD 1080p component at 3.0Gb/s (ST 425-1) level A
		24, 25, 30	Y'C <sub>B</sub> C <sub>R</sub> /RGB/4:4:4(4)	12bpc	HD 1080p Y'C <sub>B</sub> C <sub>R</sub> /RGB component at 3.0Gb/s (ST 425-1) level A

Type	Format (Hres x Vres)	Frame rate (Hz)	Sampling	Bit-depth	Notes
		24, 25, 30	Y'C <sub>B</sub> C <sub>R</sub> /4:2:2(4)	12bpc	HD 1080p Y'C <sub>B</sub> C <sub>R</sub> component at 3.0Gb/s (ST 425-1) level A
		48, 50, 60	Y'C <sub>B</sub> C <sub>R</sub> /RGB/4:4:4(4)	10bpc	HD 1080p Y'C <sub>B</sub> C <sub>R</sub> /RGB component at 6.0Gb/s (ST 2081-10) mode 2 structure II
		48, 50, 60	Y'C <sub>B</sub> C <sub>R</sub> /RGB/4:4:4	12bpc	HD 1080p Y'C <sub>B</sub> C <sub>R</sub> /RGB component at 6.0Gb/s (ST 2081-10) mode 2 structure III
4K	4096x2160	48, 50, 60	Y'C <sub>B</sub> C <sub>R</sub> /4:2:2	10bpc	2160p Y'C <sub>B</sub> C <sub>R</sub> component at 6.0Gb/s (ST 2081-10) mode 1 structure 1
		24, 25, 30	Y'C <sub>B</sub> C <sub>R</sub> /RGB/4:4:4(4)	10bpc	2160p Y'C <sub>B</sub> C <sub>R</sub> /RGB component at 12.0Gb/s (ST 2082-10) mode 1 structure 2
		24, 25, 30	Y'C <sub>B</sub> C <sub>R</sub> /RGB/4:4:4	12bpc	2160p Y'C <sub>B</sub> C <sub>R</sub> /RGB component at 12.0Gb/s (ST 2082-10) mode 1 structure 3
		24, 25, 30	Y'C <sub>B</sub> C <sub>R</sub> /4:2:2(4)	12bpc	2160p Y'C <sub>B</sub> C <sub>R</sub> component at 12.0Gb/s (ST 2082-10) mode 1 structure 4

**Dual-link 2D: 2K and 4K (HD / UHD)**

Dual-link SDI is a fixed configuration where:

- SDI 1 = link 1 of input 1
- SDI 2 = link 2 of input 1
- SDI 3 = link 1 of input 2

- SDI 4 = link 2 of input 2

The following Dual-link (two cable) 2D SDI input formats are supported.

**Table 9: Dual-link 2D: 2K and 4K (HD / UHD) image formats**

Type	Format (Hres x Vres)	Frame rate (Hz)	Sampling	Bit-depth	Notes
2K	2048x1080	48, 50, 60	Y'C <sub>B</sub> C <sub>R</sub> /RGB/4:4:4(4)	10bpc	Y'C <sub>B</sub> C <sub>R</sub> /RGB component at dual-link 3Gb/s (ST 425-3) level A structure II
			Y'C <sub>B</sub> C <sub>R</sub> /RGB/4:4:4	12bpc	Y'C <sub>B</sub> C <sub>R</sub> /RGB component at dual-link 3Gb/s (ST 425-3) level A structure III
			Y'C <sub>B</sub> C <sub>R</sub> /4:2:2	12bpc	Y'C <sub>B</sub> C <sub>R</sub> component at dual-link 3Gb/s (ST 425-3) level A structure IV
			Y'C <sub>B</sub> C <sub>R</sub> /4:2:2:4	12bpc	Y'C <sub>B</sub> C <sub>R</sub> component at dual-link 3Gb/s (ST 425-3) level A structure IV
4K	4096x2160	48, 50, 60	Y'C <sub>B</sub> C <sub>R</sub> /4:2:2	10bpc	Y'C <sub>B</sub> C <sub>R</sub> component at dual-link 6Gb/s (ST 2081-11) mode 1
			Y'C <sub>B</sub> C <sub>R</sub> /RGB/4:4:4(4)	10bpc	Y'C <sub>B</sub> C <sub>R</sub> /RGB component at dual-link 6Gb/s (ST 2081-11) mode 1
		24, 25, 30	Y'C <sub>B</sub> C <sub>R</sub> /RGB/4:4:4	12bpc	Y'C <sub>B</sub> C <sub>R</sub> /RGB component at dual-link 6Gb/s (ST 2081-11) mode 1
			Y'C <sub>B</sub> C <sub>R</sub> /4:2:2	12bpc	Y'C <sub>B</sub> C <sub>R</sub> component at dual-link 6Gb/s (ST 2081-11) mode 1

Type	Format (Hres x Vres)	Frame rate (Hz)	Sampling	Bit-depth	Notes
			Y'C <sub>B</sub> C <sub>R</sub> /4:2:2:4	12bpc	Y'C <sub>B</sub> C <sub>R</sub> component at dual-link 6Gb/s (ST 2081-11) mode 1

### Quad-link 2D: 4K (UHD)

Quad-link 2D is a fixed configuration where the quad-link input is as follows.

- SDI 1 = link 1
- SDI 2 = link 2
- SDI 3 = link 3
- SDI 4 = link 4

The following Quad-link (four cable) 2D image formats are supported.

**Table 10: Quad-link 2D: 4K (UHD) image formats**

Type	Format	Frame rate (Hz)	Sampling	Bit-depth	Notes
4K	4096x2160	24, 25, 30	Y'C <sub>B</sub> C <sub>R</sub> /RGB/4:4:4(4)	10bpc	Y'C <sub>B</sub> C <sub>R</sub> /RGB component at quad-link 3Gb/s (ST 425-5) level A structure 2
			Y'C <sub>B</sub> C <sub>R</sub> /RGB/4:4:4	12bpc	Y'C <sub>B</sub> C <sub>R</sub> /RGB component at quad-link 3Gb/s (ST 425-5) level A structure 3
			Y'C <sub>B</sub> C <sub>R</sub> /4:2:2(4)	12bpc	Y'C <sub>B</sub> C <sub>R</sub> component at quad-link 3Gb/s (ST 425-5) level A structure 4
			Y'C <sub>B</sub> C <sub>R</sub> /4:2:2	12bpc	Y'C <sub>B</sub> C <sub>R</sub> component at quad-link 3Gb/s (ST 425-5) level A structure 4
		48, 50, 60	Y'C <sub>B</sub> C <sub>R</sub> /RGB/4:4:4(4)	10bpc	Y'C <sub>B</sub> C <sub>R</sub> /RGB component at quad-link 6Gb/s

Type	Format	Frame rate (Hz)	Sampling	Bit-depth	Notes
					(ST 2081-12) mode 2 structure III
			Y'C <sub>B</sub> C <sub>R</sub> /RGB/4:4:4	12bpc	Y'C <sub>B</sub> C <sub>R</sub> /RGB component at quad-link 6Gb/s (ST 2081-12) mode 2 structure III
			Y'C <sub>B</sub> C <sub>R</sub> /4:2:2:4	12bpc	Y'C <sub>B</sub> C <sub>R</sub> component at quad-link 6Gb/s (ST 2081-12) mode 2 structure IV

## Integrated Media Block (IMB) video source

Connect a compatible device to either the S2 or S4 interface of the projector to send digital video data from an IMB to the projector.

**Table 11: Supported IMB input configurations**

Input configuration	Description
IMB – S2 or S4	Enables connection of MPEG-2 video formats.
	Enables connection of MPEG-2 MXF interop video formats.
	Enables connection of SMPTE-compatible 2D and 3D video formats

Contact Christie Technical Support to learn which S2 and S4 IMB devices are compatible with Christie projectors.

## Series 2 IMB video formats

S2 IMB video format support is determined by the IMB make and model. Refer to the associated IMB documentation to understand which of the following video signals are supported.

All MPEG-2 content is converted in the media block to RGB 4:4:4 8-bit before play out.

**MPEG**

**Table 12: MPEG image formats**

Format	Resolution	Max Frame Rate 2D	Max Frame Rate 3D	Min Frame Rate	Bit Depth
VGA	640x480	120.0	120.0	23.0	8-bits
525 4SIF	704x480	120.0	120.0	23.0	8-bits
525 SD	720x480	120.0	120.0	23.0	8-bits
4CIF	704x576	120.0	120.0	23.0	8-bits
625 SD	800x600	120.0	120.0	23.0	8-bits
SVGA	1024x768	79.6	79.6	23.0	8-bits
XGA	1024x768	79.6	79.6	23.0	8-bits
720p HD	1280x720	68.0	68.0	23.0	8-bits
4VGA	1280x960	51.0	51.0	23.0	8-bits
SXGA	1280x1024	47.8	N/A	23.0	8-bits
525 16SIF	1408x960	46.3	N/A	23.0	8-bits
16CIF	1408x1152	38.6	N/A	23.0	8-bits
4SVGA	1600x1200	32.6	N/A	23.0	8-bits
1080 HD	2048x1080	30.0	N/A	23.0	8-bits

**MPEG-2 MXF interop – 2D**

**Table 13: MPEG-2 MXF interop – 2D image formats**

Format	Resolution	Max Frame Rate 2D	Max Frame Rate 3D	Min Frame Rate	Bit Depth
VGA	640x480	120.0	120.0	23.0	8-bits
525 4SIF	704x480	120.0	120.0	23.0	8-bits
525 SD	720x480	120.0	120.0	23.0	8-bits
4CIF	704x576	120.0	120.0	23.0	8-bits
625 SD	800x600	120.0	120.0	23.0	8-bits
SVGA	1024x768	79.6	79.6	23.0	8-bits
XGA	1024x768	79.6	79.6	23.0	8-bits
720p HD	1280x720	68.0	68.0	23.0	8-bits
4VGA	1280x960	51.0	51.0	23.0	8-bits
SXGA	1280x1024	47.8	N/A	23.0	8-bits
525 16SIF	1408x960	46.3	N/A	23.0	8-bits

Format	Resolution	Max Frame Rate 2D	Max Frame Rate 3D	Min Frame Rate	Bit Depth
16CIF	1408x1152	38.6	N/A	23.0	8-bits
4SVGA	1600x1200	32.6	N/A	23.0	8-bits
1080 HD	2048x1080	30.0	N/A	23.0	8-bits

**SMPTTE-compatible cinema formats - 2D (JPEG 2000)**

Table 14: SMPTTE-compatible cinema formats - 2D (JPEG 2000) image formats

Specification	Resolution	Frame Rate	Color Format	Bit Depth
SMPTE 428-1-2006	2048x1080	24.0	X'Y'Z' (4:4:4)	12-bits
SMPTE 428-11-2009	2048x1080	25.0	X'Y'Z' (4:4:4)	12-bits
SMPTE 428-11-2009	2048x1080	30.0	X'Y'Z' (4:4:4)	12-bits
SMPTE 428-1-2006	2048x1080	48.0	X'Y'Z' (4:4:4)	12-bits
SMPTE 428-11-2009	2048x1080	50.0	X'Y'Z' (4:4:4)	12-bits
SMPTE 428-11-2009	2048x1080	60.0	X'Y'Z' (4:4:4)	12-bits
--	2048x1080	100.0	X'Y'Z' (4:4:4)	12-bits
--	2048x1080	120.00	X'Y'Z' (4:4:4)	12-bits
SMPTE 428-1-2006	4096x2160	24.0	X'Y'Z' (4:4:4)	12-bits
SMPTE 428-11-2009	4096x2160	25.0	X'Y'Z' (4:4:4)	12-bits
SMPTE 428-11-2009	4096x2160	30.0	X'Y'Z' (4:4:4)	12-bits
--	4096x2160	48	X'Y'Z' (4:4:4)	12-bits
--	4096x2160	50	X'Y'Z' (4:4:4)	12-bits
--	4096x2160	60	X'Y'Z' (4:4:4)	12-bits
--	4096x2160	100	X'Y'Z' (4:4:4)	12-bits
--	4096x2160	120	X'Y'Z' (4:4:4)	12-bits

**SMPTTE-compatible cinema formats - 3D (JPEG 2000)**

Table 15: SMPTTE-compatible cinema formats - 3D (JPEG 2000) image formats

Specification	Resolution	Frame Rate (per eye)	Color Format	Bit Depth
SMPTE 428-1-2006	2048 x 1080	24.0 x 2	X'Y'Z' (4:4:4)	12-bits
SMPTE 428-1-2006		48.0 x 2		
		50.0 x 2		
SMPTE 428-11-2009		60.0 x 2		

Specification	Resolution	Frame Rate (per eye)	Color Format	Bit Depth
	4096 x 2160	24.0 x 2	X'Y'Z' (4:4:4)	12-bits
		48.0 x 2		
		50.0 x 2		
		60.0 x 2		

## HDMI video source connection from an IMB

The projector can accept digital video data from HDMI sources connected to applicable IMB devices. The input configurations supported are determined by the IMB device directly.

### IMB devices supporting HDMI selection from the projector UI

Contact Christie Technical Support to learn which IMB devices provide HDMI source selection from the projector UI.

HDMI input selection directly from the IMB may also be possible via the IMB UI. The input configurations supported are determined by the IMB make and model.

## SDI video source connection from an IMB

The projector can accept digital video data from SDI sources connected to applicable IMB devices. The input configurations supported are determined by the IMB device directly.

### IMB devices supporting SDI selection from the projector UI

Contact Christie Technical Support to learn which IMB devices provide SDI source selection from the projector UI.

SDI input selection directly from the IMB may also be possible via the IMB UI. The input configurations supported are determined by the IMB make and model.



# Using channels to set input signal parameters

Channels store customized projector settings for different video input signal parameters.



The following describes only those parameters associated with input signal selection that should be configured by the user.

Additional parameter settings are required to fully describe a channel setup. Refer to *CineLife+ User Guide (P/N: 020-103073-XX)* for further information.

To create a new channel or edit the input video signal parameters for an existing channel, follow these steps.

1. In the left navigation menu, select Channel Setup.
2. Select + Add Channel to create a new channel or, in the left panel, select a channel name to select it for editing.
3. To define the input video signal parameters for the channel, complete the following fields.

Field name	Description
Name	The channel name
Input Type	<p>Select the input signal sources from one of the following.</p> <ul style="list-style-type: none"> <li>• HDMI Input 1</li> <li>• HDMI Input 2</li> <li>• IMB</li> <li>• IMB HDMI (Available only if the selected IMB device supports HDMI selection from projector UI.)</li> <li>• IMB SDI (Available only if the selected IMB device supports SDI selection from projector UI.)</li> <li>• SDI - 1</li> <li>• SDI - 2</li> <li>• SDI - 3</li> <li>• SDI - 4</li> <li>• SDI - Dual-Input (1,2)</li> <li>• SDI - Dual-Input (3,4)</li> <li>• SDI - Quad</li> </ul>
Data Format	The default is AUTO.

Field name	Description
	The bit-depth, sampling format, and color space of the input signal is automatically determined from metadata carried in the source.
Scan Type	<p>Determines the input scanning format. Select one of the following.</p> <ul style="list-style-type: none"> <li>• Auto (default setting) The scanning format of the input signal (interlaced or progressive) is automatically determined from metadata carried in the source or by measuring scanning parameters of the source.</li> <li>• Progressive Forces the input signal scanning format to progressive, overriding any metadata in the input signal.</li> </ul>
3D Sync Input Mode	<p>Specifies whether a specific frame of input data has left eye or right eye data. Select one of the following.</p> <ul style="list-style-type: none"> <li>• Auto (default setting) The left-eye / right eye 3D-sync information is automatically determined from metadata carried in the source or from the specific input type selection.</li> <li>• 2D mode Forces the input signal to be interpreted as a 2D signal, overriding any metadata in the input signal.</li> </ul>
Color Space	<p>Specifies the method of internal color decoding that will be applied to the currently selected input source. Select from the following.</p> <ul style="list-style-type: none"> <li>• Auto (default setting) Appropriate color decoding will be automatically selected in accordance with the input signal color format.</li> <li>• RGB (Full Range) Appropriate color decoding will be selected in accordance with the input signal being a full-range, 12-bit per component, RGB color format.</li> <li>• RGB (Limited Range) Appropriate color decoding will be selected in accordance with the input signal being a limited-range, 10-bit per component, RGB color format.</li> <li>• XYZ Appropriate color decoding will be selected in accordance with the input signal being a full-range, 12-bit per component, XYZ color format.</li> </ul>

4. Select Save.

# Managing the light source

Learn how to configure a laser file and use the projector's LiteLOC™ feature.

The laser file allows you to control the power settings of the red, green, and blue (RGB) lasers. The LiteLOC™ feature ensures that color and brightness are held at the level you set.

You can create multiple laser files to manage varying screen sizes, brightness requirements, room temperatures in the projection booth, and types of content (such as 2D, 3D, and alternative content).

## Creating a new laser file for CP4415-RGB and CP4420-RGB

Create a laser file to store the power settings for the RGB laser light source and the maximum expected room temperature for the projection booth.

The maximum (MAX) power limit for Red and Green changes according to the value set for the maximum expected room temperature. For Red, Green, and Blue power levels, system stability may be affected if levels are set below the minimum (MIN) power limit shown.

To ensure color and brightness are held at the required levels for your installation, Christie recommends enabling LiteLOC for each laser file you create.

When refining the laser power settings, the amount of time required to re-stabilize the projector depends on the size of the adjustment. For very small adjustments to the expected room temperature or power settings, the projector requires only 1 or 2 minutes to re-stabilize. For larger adjustments, the projector may require up to 15 minutes to re-stabilize.

1. In the left navigation pane, select **Laser Settings** > **Laser Power/LiteLOC Setup**.

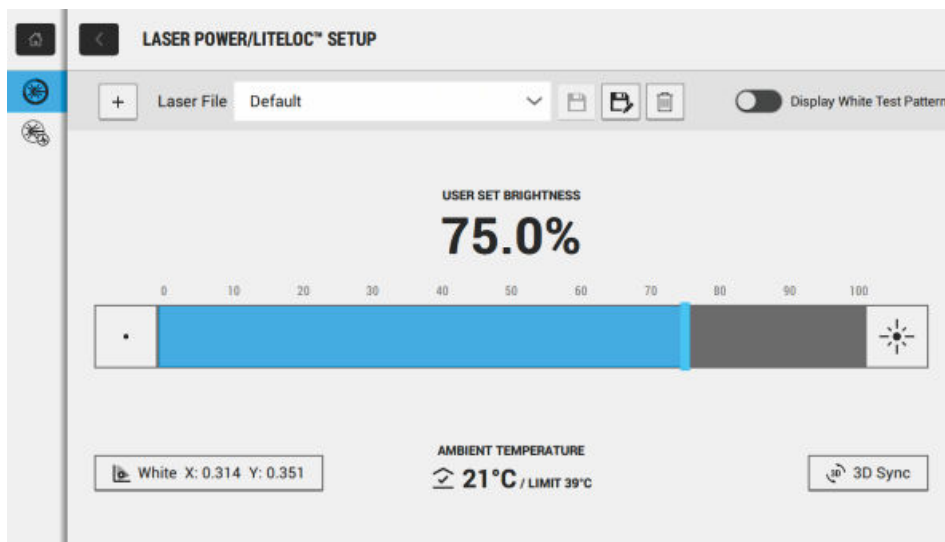

2. (Optional) Select **Display White Test Pattern**.
3. To create a new laser file, select **Create**. 
4. In the Create dialog, type a name for the new laser file and select **Create**.
5. If the laser file will be associated with a 3D channel, select **3D Sync**.
6. To set the value for White, select the current values and adjust them up or down as needed.
7. Set the brightness levels as required for your projection environment and allow the projector to stabilize for 15 minutes.  
System stability may be affected if you set a power level below the minimum power level recommended.
8. If white or brightness is not at the target level, adjust the settings to achieve the target, and then allow the projector to re-stabilize for an additional 3 to 5 minutes.



The projector is considered stable when there are no further adjustments and you obtain the same screen state results after two sets of measurements, 5 minutes apart.

9. To save the new laser file, select **Save**. 

Color sensor (CSense) data are displayed on the interface to provide feedback on the current color sensor information.

## Modifying an existing laser file

Modify the settings in the laser file to change the laser power settings or the maximum expected room temperature.

When refining the laser power settings, the amount of time required to re-stabilize the projector depends on the size of the adjustment. For very small adjustments to the expected room temperature or power settings, the projector requires only 1 or 2 minutes to re-stabilize. For larger adjustments, the projector may require up to 15 minutes to re-stabilize.

1. In the left navigation pane, select **Laser Settings > Laser Power/LiteLOC Setup**.
2. To begin modifying the settings, select **Display White Test Pattern**.
3. From the Laser File list, select the laser file to edit.
4. Select the **LiteLOC** slider to lock the settings.  
The color of the slider turns to green to indicate the settings are locked.
5. Once the correct color and brightness are achieved and the projector has stabilized, to save the new settings select **Save** .

## Copying existing laser settings to a new file

Copy an existing laser file when you want to create a new file with similar settings.

1. In the left navigation pane, select **Laser Settings > Laser Power/LiteLOC Setup**.
2. From the Laser File list, select the file you want to copy.
3. To save the new laser file, select **Save As** .
4. Type a new name for the laser file and select **Save**.

5. Adjust the brightness and white settings as required for the new configuration.

## Deleting a laser file

Delete a laser file when the configuration is no longer required.

1. In the left navigation menu, select **Laser Settings > Laser Power/LiteLOC Setup**.
2. Select **Display White Test Pattern**.
3. In the Laser File list, select the file to delete.
4. Select **Delete** .
5. To confirm the deletion, select **Delete**.

# Adjusting the image

Learn how to adjust image geometry so it displays correctly.

## Calibrating the Intelligent Lens System

On CineLife+ 4K-RGB projectors, the Intelligent Lens System (ILS) is activated by default.

Use the Auto Calibrate feature of the ILS to find and compensate for motor backlash, and to determine the movement range for the currently installed lens.

1. In the left navigation menu, select **Image Settings > ILS File Setup**.
2. From the ILS File list, select an available ILS file.
3. Select **Auto Calibrate**.
4. Select **Continue**.  
The system performs the lens calibration.

## Correcting vignetting

An image that is brighter at the center than it is at the sides needs vignetting correction.

If your image suffers from vignetting, the lens has reached the end of its offset travel range.

If your installation does not allow the image to be centered with the center of the screen, move the entire projector in the direction of lens travel.

## Adjusting tilt and leveling the projector

To ensure optimum performance, install the projector so it is centered and parallel with the screen.

To compensate for tilt or offset, you can adjust the projector feet and the lens mount position.

This product must be installed in a landscape orientation, with all four feet supported on a level surface. Do not install or operate the projector in an inverted position. If your site has any installation requirements other than a typical theater projection booth, contact Christie for assistance.



The front-to-back tilt of the projector must not exceed 15° in a downward direction or 5° in an upward direction. The side-to-side tilt must be within +3° to -3° of level.

1. To adjust the height of the projector, loosen the lock nut on the adjustable feet on the bottom of the projector.

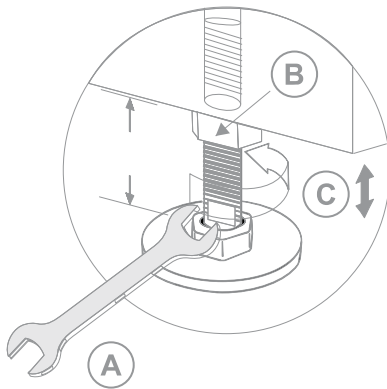

A	19 mm (0.75 in.) wrench
B	Lock
C	Turn to adjust height

2. Extend or retract the feet.
3. When the adjustment is correct, tighten the lock nut.

## Correcting keystone effect

Learn how to adjust the image to correct keystone effect.

Keystone effect occurs when you project an image onto the screen at an angle. As a result, the image appears distorted and resembles a trapezoid.



When making the adjustments, set the light source to minimum power.

Horizontal keystone	Vertical keystone
Projector skewed horizontally to the screen	Projector tilted vertically to the screen

1. If the image suffers from slight keystone effect, it can be corrected with electronic cropping.

2. If the keystone effect is severe, you can unevenly adjust the feet to compensate for projector tilt.

It is recommended that you use lens offset to align the center of the image to the center of the screen before you correct the keystone effect.

3. If one side of the image is longer than another, adjust the tilt and level of the projector.

## Displaying a test pattern

Display a test pattern to refine and adjust the projected image, or to diagnose and correct image issues.

1. In the right toolbar, select **Test Patterns**. 
2. Select **Full Screen**.
3. Select a test pattern.  
When a test pattern is active, a blue bar appears below the test pattern icon in the right pane.
4. To display a 2D test pattern in 3D mode, select the **3D Sync** option.  
The **3D Sync** option is selected automatically for 3D test patterns. 3D test patterns cannot be displayed in 2D mode.
5. To change the frame rate of the test pattern display, select from the available Frame Rate options:
  - For 2D test patterns, the available frame rates are 24, 30, 48, and 60 Frames Per Second (FPS). The default value is 24 FPS.
  - For 3D test patterns, the available frame rates are 48 and 60 FPS. The default value is 48 FPS.

Changing the frame rate of the display can assist with color measurement when working with corrected colors.

When you change the frame rate option, that option is applied to the next test pattern you select unless it is not available for that pattern. If a selected frame rate is not available, the default frame rate is applied for the test pattern display.

## Adjusting the integrator rod and fold mirror

Understand how to adjust the integrator rod and fold mirror to control the illumination spot on the DMD.

Extreme misalignment of projection optics can cause permanent damage to critical optical components. Only Christie qualified technicians can perform internal optical adjustments.

The integrator rod and fold mirror adjustments are set by Christie. Make adjustments only if screen shadows are visible.



When adjusting the fold mirror, set the light source to minimum power.

1. In the right toolbar, select **Test Patterns**. 
2. Select the **RGB-4K-Integrator Rod** test pattern and display it full screen.



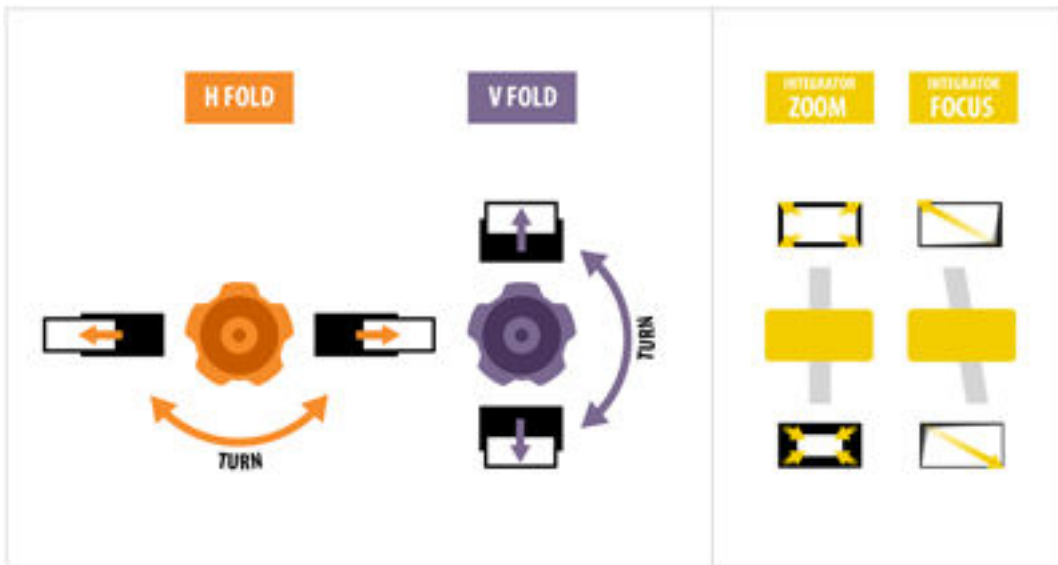

Refer to the test pattern for guidance on making the adjustments. The right panel of the test pattern provides information about the integrator zoom and focus adjustments. The left panel provides information about the fold mirror adjustments.

3. Open the Service door on the side of the projector.
4. To use the integrator rod optical controls, open the access door for the Zoom and Focus paddles.

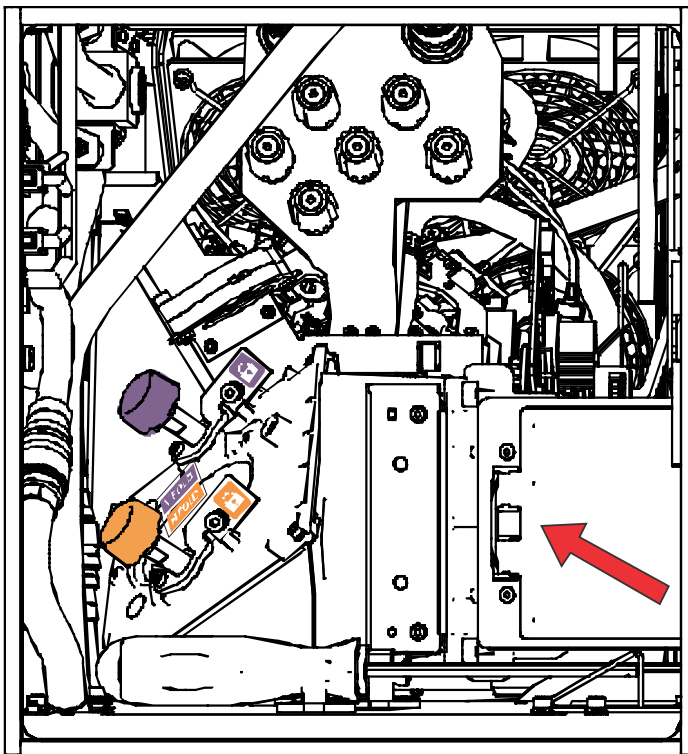

5. Loosen the lock screw for the Zoom and Focus paddles.

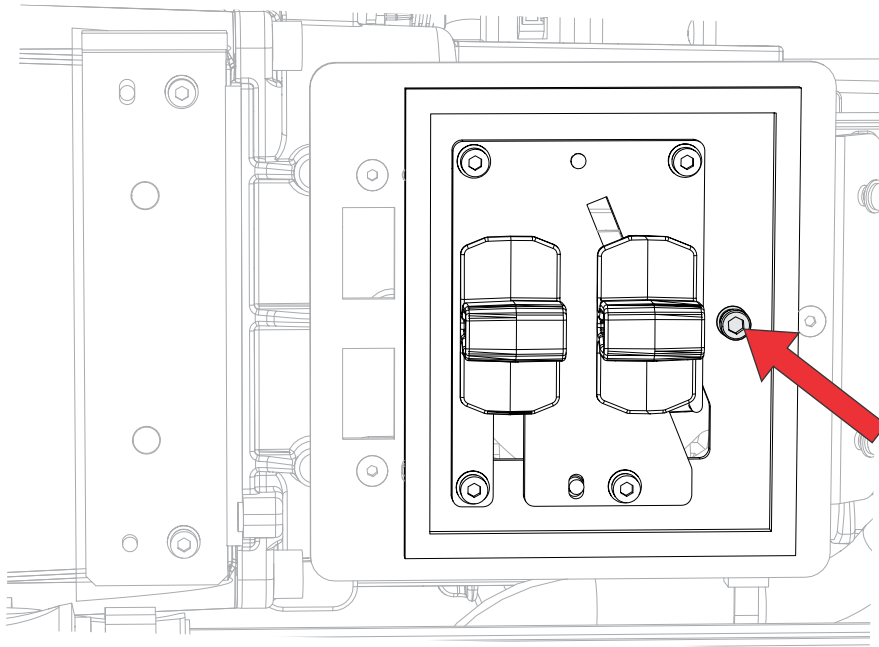

6. Set the integrator rod Zoom paddle to the minimum.
7. Loosen the fold mirror screws to unlock the fold mirror adjustment knobs.

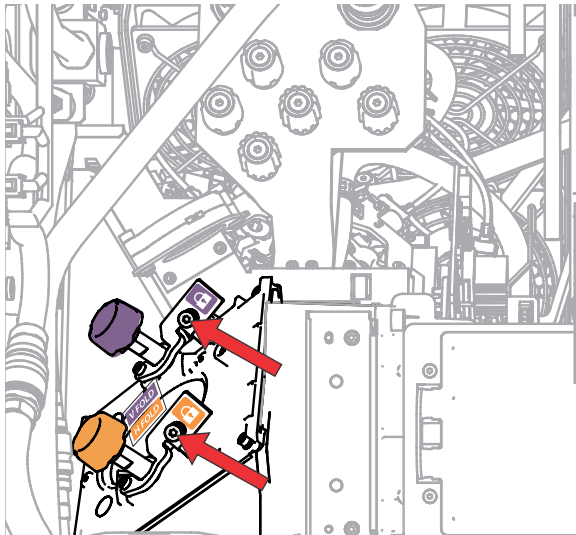

8. To make horizontal adjustments on the fold mirror, use the orange adjustment knob.  
To make vertical adjustments on the fold mirror, use the purple adjustment knob.

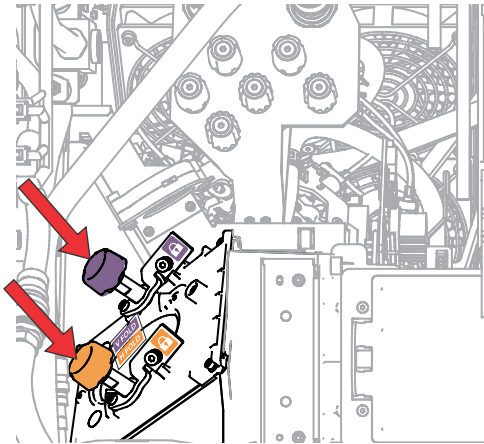

9. Adjust the fold mirror until either the top left edge or the bottom right edge of the illumination spot becomes visible on the DMD.
10. Adjust the integrator rod Focus paddle to optimize focus for one of the following:
  - Along the top edge of the image, approximately one-third across the image from the left.
  - Along the bottom edge of the image, approximately one-third across the image from the right.
11. Adjust the fold mirror to center the image on the DMD array.
12. Use the integrator rod Zoom paddle to increase the zoom until the entire active area is filled, with no dark areas at the edges or corners.  
Ensure that overfill is minimized to improve DMD life and system optical efficiency for brightness.
13. Once the adjustments are complete, tighten the lock screw for the Zoom and Focus paddles, and the two fold mirror screws.
14. Close the access door for the Zoom and Focus paddles.

## Adjusting the boresight

A boresight adjustment balances the tilt of the lens mount to compensate for screen-to-projector tilt.



**Warning!** If not avoided, the following could result in death or serious injury.

- Do not look directly into the lens when the light source is on. The extremely high brightness can cause permanent eye damage.
- FIRE HAZARD! Keep hands, clothes, and all combustible material away from the concentrated light beam of the projector.



**Caution!** If not avoided, the following could result in minor or moderate injury.

- This procedure must be performed by Christie qualified technicians.



When making the adjustments, set the light source to minimum power.

The following steps are intended to achieve the highest quality image distributed across the full screen.

1. Close the shutter on the projector to avoid accidental exposure to the projection beam when working in close proximity to the projection lens.

- Using a 3 mm driver, unlock the horizontal and vertical lock screws (Lock A, B, and C).  
To unlock the vertical lock screw (Lock C), flip open the cover flap (G) using the screwdriver.

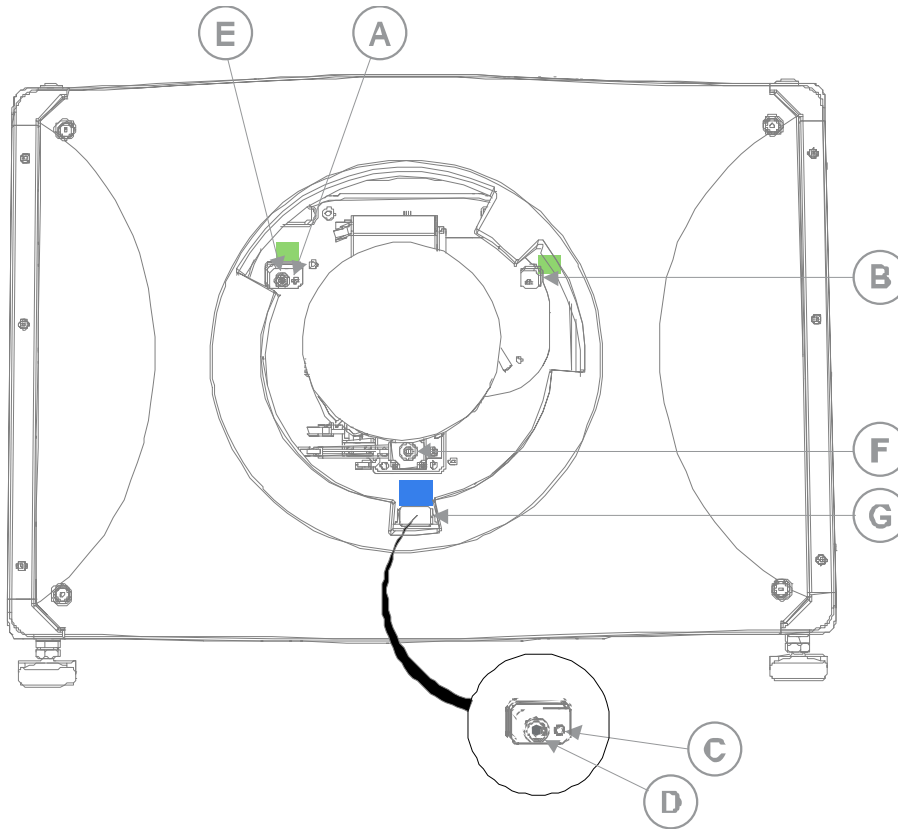

A	Horizontal lock screw (Lock A)
B	Horizontal lock screw (Lock B)
C	Vertical lock screw (Lock C)
D	Vertical boresight screw
E	Horizontal boresight screw
F	Manual focus knob
G	Cover flap

- Open the shutter on the projector.
- In the right toolbar, select **Test Patterns** .
- Select the **RGB-4K-Boresight** pattern and display it full screen.

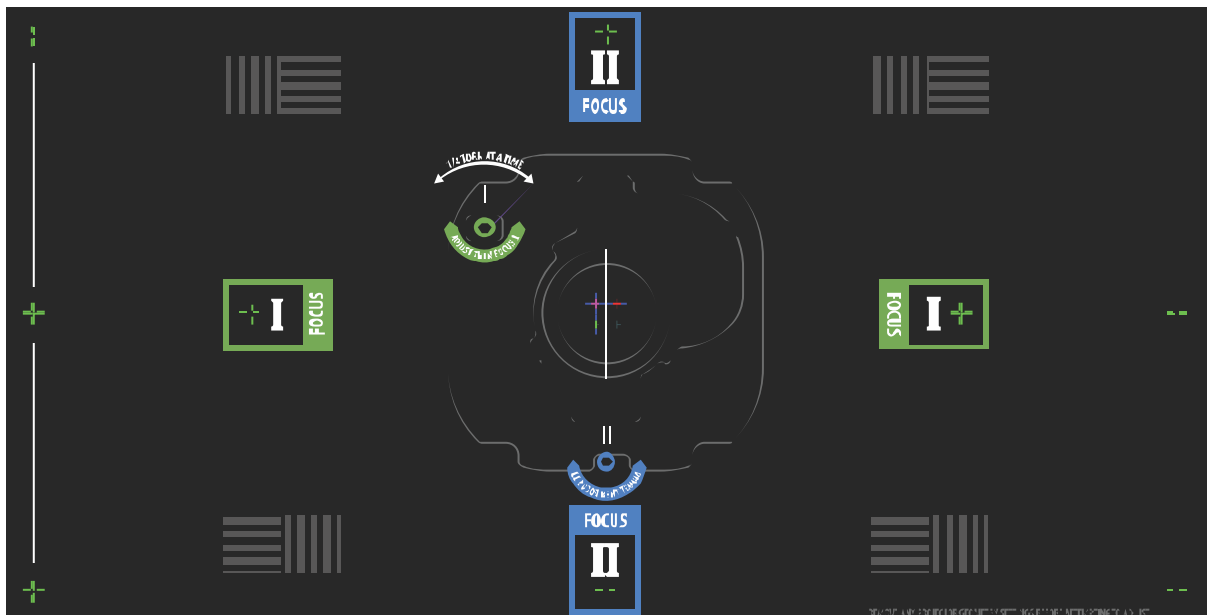

When adjusting the boresight screws, ensure that the shutter is closed to avoid accidental exposure to the projection beam when operating in close proximity to the projection lens. Open the shutter only to view the test pattern.

6. Start with the horizontal boresight adjustment. Use the ILS controls to move the projection lens into the projector, or turn the manual focus knob (F) counterclockwise to slightly defocus the green cross-hair patterns (+) at the right and left edges of the test pattern.
7. Use the ILS controls or turn the focus knob (F) clockwise to begin focusing the image. Watch for either the left or right cross-hair patterns (+) to come into focus.
8. If the left side comes into focus first, use a 5 mm driver to turn the horizontal boresight adjustment screw (E) clockwise until the left and right are equally out of focus. If the right side comes into focus first, turn the horizontal boresight screw counterclockwise.
9. Repeat steps 6 to 8 as required to obtain an even focus at the right and left edges of the screen.
10. Next perform the vertical boresight adjustment. Use the ILS controls to move the projection lens into the projector, or turn the focus knob (F) counterclockwise to slightly defocus the green cross-hair patterns (+) at the top and bottom of the screen.
11. Use the ILS controls or turn the focus knob (F) clockwise to begin focusing the image. Watch for either the top or bottom cross-hair patterns (+) to come into focus.
12. If the bottom comes into focus first, use a 5 mm driver to turn the vertical boresight adjustment screw (D) counterclockwise until the top and bottom are equally out of focus. If the top comes into focus first, turn the vertical boresight screw clockwise.
13. Repeat steps 10 to 12 as required to obtain an even focus at the top and bottom of the screen.
14. Once the correct focus has been achieved, lock the three lock screws.  
When locking the lock screws, start with the horizontal lock screws (Lock A and Lock B) and turn them until they just touch the base. Repeat for the vertical lock screw (Lock C). Continue the gradual tightening of each screw, until all lock screws are tight.



When stabilizing image vibration, Lock B may be left locked or unlocked at the discretion of the installer.

15. If you used the focus knob (F) to make the adjustments manually, run an ILS auto calibration.
16. Fine tune the focus on cross-hair patterns **I** (horizontal) and **II** (vertical) using the ILS controls only.  
The goal is to obtain good focus at the center and on all sides of the screen, including the square patterns across the screen.

## Adjusting DMD convergence

A convergence problem can be identified when one or more projected colors (red, green, and blue) appears misaligned when examined with a convergence test pattern.

The three colors should overlap to form pure white lines throughout the image and one or more poorly converged individual colors may appear adjacent to some or all of the lines.

When adjusting the convergence, you are adjusting red and green to blue.



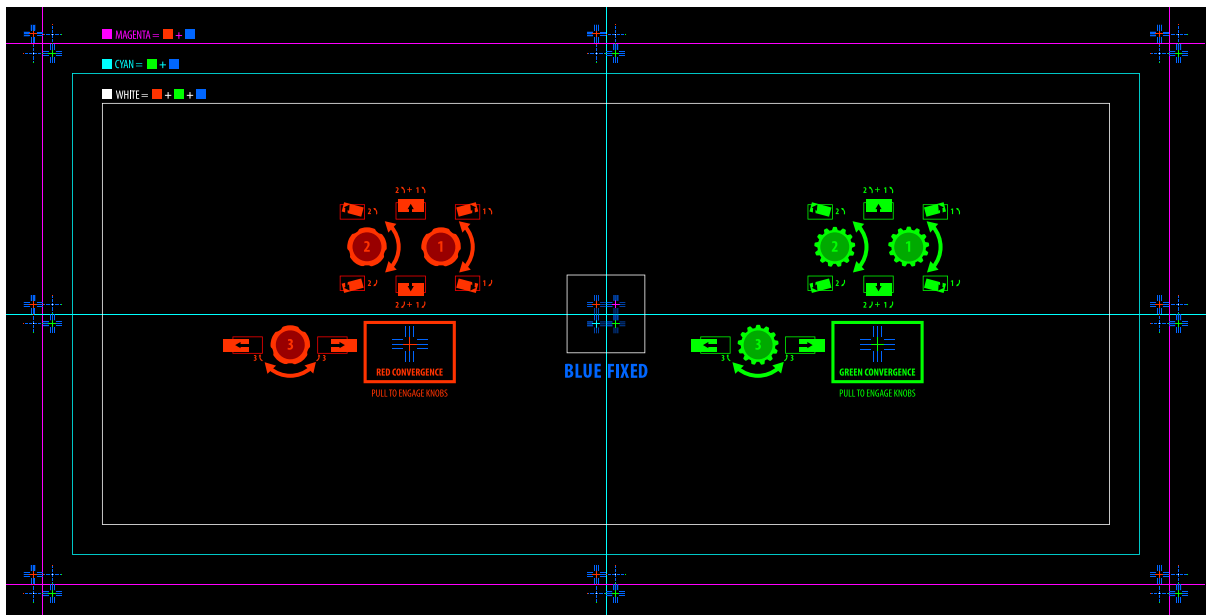

If you wear glasses with corrective lenses when performing this adjustment, ensure that you are viewing the test pattern on a straight angle through the optical axis of your glasses, and not from a tilted or angled perspective. This avoids a prismatic effect that can appear to shift convergence when viewing at an angle.

1. Before adjusting DMD convergence, ensure the projector has reached a steady operational state. If switching from a white or bright test pattern to a dark convergence test pattern, or if warming up the projector after a shutdown, allow 15 minutes for stabilization so that the optics can reach a steady state.
2. In the right toolbar, select **Test Patterns**. 
3. Select the **RGB-4K-Convergence** test pattern and display it full screen.

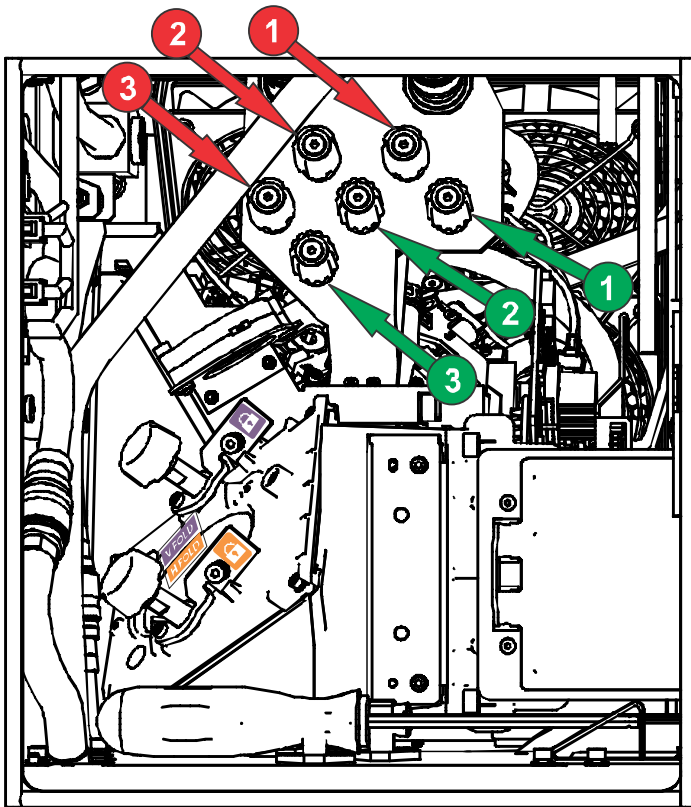

4. Open the Service door on the side of the projector.
5. To adjust the convergence knobs, use the 3 mm driver included with the projector.  
If adjusting by hand without using the tool, pull out the convergence adjustment knobs to engage them.



6. Use the Convergence test pattern to assist with adjusting the horizontal and vertical lines. Horizontal adjustments are controlled by adjusting knob 3. Vertical convergence and rotation are controlled by adjusting knobs 1 and 2. Christie recommends rotating a single knob a maximum of a quarter rotation before adjusting the second knob a quarter rotation. For example, if using one hand, turn the left knob a quarter rotation and then the right knob a quarter rotation, and so on. Adjusting a single knob for vertical or rotational adjustment to an extreme before adjusting the second knob may result in the convergence mechanism binding.
  -  For the best stability, Christie recommends setting convergence while rotating the knobs in a clockwise direction. This may require first adjusting convergence by turning the knobs counter-clockwise, and finalizing the convergence with a clockwise approach. This applies to all knobs.
7. When complete, push in all the convergence adjustment knobs to disengage them.

## Correcting on-screen color

After installation, further image adjustments may be required to correct color on the screen.

The next steps may include creating a Measured Color Gamut Data (MCDG) file and configuring a Pureformity Color™ Technology (PCT) file to achieve optimal color and brightness uniformity.

For more information on managing color settings, see the *CineLife+ User Guide (P/N: 020-103073-XX)*.

# Regulatory

This product conforms to the latest regulations and standards related to product safety, environmental, and electromagnetic compatibility (EMC) requirements.

## Safety

- EN 60950-1:2006 + A11:2009 + A1:2010 + A12:2011 + A2:2013 – Information Technology Equipment – Safety – Part 1: General Requirements
- CAN/CSA C22.2 No. 60950-1-07 + Am 1:2011+ Am 2:2014 Information Technology Equipment Safety Part 1: General Requirements
- ANSI/UL 60950-1-2014 – Information Technology Equipment – Safety – Part 1: General Requirements
- IEC 60950-1:2005 + Amendment 1:2009 + Amendment 2:2013 – Information Technology Equipment - Safety - Part 1: General Requirements
- IEC 62471-5:2015 - Photobiological Safety Of Lamps And Lamp Systems - Part 5: Image Projectors
- IEC 60825-1:2014 - Safety of Laser Products - Part 1: Equipment Classification and Requirements
- ANSI Z136.1 (2014) – Safety of Lasers

## Electro-magnetic compatibility

### Emissions

- CAN ICES-003 (A)/NMB-003 (A) – Information Technology Equipment (Including Digital Apparatus) – Limits and Methods of Measurement
- CISPR 32/EN 55032, Class A – Electromagnetic Compatibility of Multimedia Equipment – Emission Requirements
- FCC CFR47, Part 15, Subpart B, Class A – Unintentional Radiators
- IEC 61000-3-2/EN61000-3-2: Limits for harmonic current emissions for equipment with input current  $\leq 16$  A
- IEC 61000-3-3/EN 61000-3-3: Limitations of Voltage Changes, Voltage Fluctuations, and Flicker input current  $\leq 16$  A per phase and not subject to conditional connection

### Immunity

- CISPR 35/EN 55035 Electromagnetic compatibility of multimedia equipment - Immunity requirements

### California Law on Security



- California Law SB-327 Requiring Internet Connected Devices To Include Reasonable Security Features (California Civil Code Section 1798.91.04)

## Environmental

- EU Directive (94/62/EC) on packaging and packaging waste
- China packaging recycling mark standard (GB18455-2001)
- EU Directive (2012/19/EU) on waste and electrical and electronic equipment (WEEE) and the applicable official amendment(s).

## Corporate offices

---

Christie Digital Systems USA, Inc.  
ph: 714 236 8610

Christie Digital Systems Canada Inc.  
ph: 519 744 8005

## Worldwide offices

---

Africa  
ph: +27 (0)11 510 0094

Australia  
ph: +61 (0) 7 3624 4888

Brazil  
ph: +55 (11) 2548 4753

China (Beijing)  
ph: +86 10 6561 0240

China (Shanghai)  
ph: +86 21 6030 0500

Columbia  
ph: +57 (318) 447 3179

Germany  
ph: +49 (0) 221 99512 0

India  
ph: +91 (080) 6708 9999

Japan (Tokyo)  
ph: 81 3 3599 7481

Korea (Seoul)  
ph: +82 2 702 1601

Mexico  
ph: +52 55 4744 1790

Singapore  
ph: +65 6877 8737

Spain  
ph: +34 91 633 9990

Middle East  
ph: +971 (0) 503 6800

United Kingdom  
ph: +44 (0) 118 977 8000

United States (Arizona)  
ph: 602 943 5700

## Independent sales consultant offices

---

Italy  
ph: +39 (0) 2 9902 1161

Russia  
ph: +36 (0) 1 47 48 100



For the most current technical documentation, visit [www.christiedigital.com](http://www.christiedigital.com).

