

# Digital Cinema Solutions

Alternative content

Post production

Review rooms

Special events

Theatrical exhibition



**CHRISTIE®**



▲ Christie brings the force of cutting edge Digital Cinema technology to the biggest Star Wars party ever – Celebration IV – with the first-ever back-to-back, six-episode Saga marathon in the U.S. on May 23, 2007.

The state-of-the-art digital screening of all six Star Wars episodes on the world's most popular DLP Cinema® projector, the Christie CP2000, is one of the highlights of the massive event, which brings together tens of thousands of Star Wars fans from around the world.

The screening marks the first time all Star Wars episodes had been theatrically presented in story order (from Episode I to Episode VI),

and drew thousands of enthusiastic fans. "Star Wars Celebration IV" is produced by Lucasfilm Ltd. and Gen Con LLC.

Craig Sholder, vice-president of Entertainment Solutions at Christie comments, "The Christie 2K DLP Cinema® projector played a major role in launching Lucas' final Star Wars movie, Episode III Revenge of the Sith, with digital premieres that attracted record audiences around the world. At Star Wars Celebration IV, Lucasfilm Ltd. and Christie continue their long and productive relationship, with the Christie CP2000 series offering the most pristine, visually stunning images fans have ever seen."





Christie understands the cinema industry. We know our customers personally. With no margin for error, the show must always go on. Christie brings over 75 years of experience, knowledge and value to your cinema business. Count on Christie to know and understand your cinema needs – whether traditional or film, Digital Cinema technology.

We're 100% committed to supporting our film products and accessories. Christie was the first licensee of DLP Cinema® technology, the first Digital Cinema technology to be adapted by the Hollywood community. We

were the first to market with a networked on-screen advertising solution to help support and grow your business. Our Managed Services offers a series of professional solutions designed for total customer peace of mind from consultation to remote servicing through a Christie-managed Network Operations Center.

From concept to completion, Christie is the undisputed leader in creating quality, effective solutions for your cinema.



Christie maintains a leading position in supplying advanced projection technologies to cinemas and post-production facilities around the world. We were the first supplier of original Digital Cinema projectors to the marketplace and the first to offer 2K Digital Cinema projectors to the industry.

The Christie CP2000 projector series is the D-Cinema projector of choice for the world's leading post-production facilities. Coming from a heritage in cinema, we know what it takes to keep production schedules on track. The high reliability of our solutions mean that in the most critical situations, you can depend on Christie to outperform the competition. Christie provides unparalleled service and support from technical experts.

### CP2000-M

The Christie CP2000-M is the most compact DLP Cinema® projector in the world. Purpose-built for long term reliability, it delivers up to 12,000 lumens of output power, specifically designed to maintain DCI luminance requirements on smaller screens up to 35 feet wide. At less than 100 pounds, the projector can be transported and installed by only two people.

Based on .98" DLP Cinema® technology, the CP2000-M uses new high efficiency CDXL-20SD 2000 watt Xenon lamps, while the competition requires larger, 3000 watt lamps for the same light output - a clear Christie advantage on cost of ownership and lumens per watt.

A robust and reliable addition, the Christie CP2000-M features a new motorized lensing solution and a selection of 8 new zoom lenses to guarantee the right lens solution for virtually any auditorium with absolutely no need for resizing or scaling.

- HDCP and SNMP support as standard features
- One-piece compact design for flexible mounting and installation
- Switching 2.1kW lamp ballast for lowest ripple, maximum performance and reliability
- Split power operation for use with UPS
- Rugged design capable of being stacked for dual 3D applications on screens up to 55 feet
- Local control via flexible Christie Display Panel (CDP) and full access from anywhere via web service based GUI
- Rear access for quick and easy lamp changes
- High security locks and extensive logging for maximum security
- Optional M-MALM for use with optional anamorphic or wide converter lens
- New Intelligent Lens System (ILS) custom designed for cinema for reliable motorized lens operation. Not adapted from the rental staging industry
- Also available in a post production version, the CP2000-MR

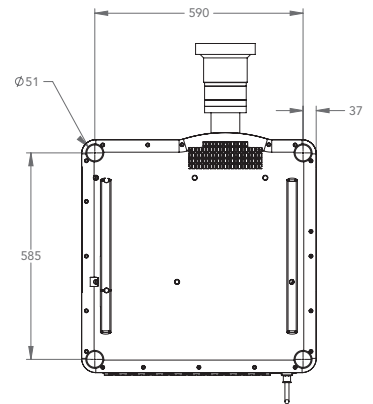
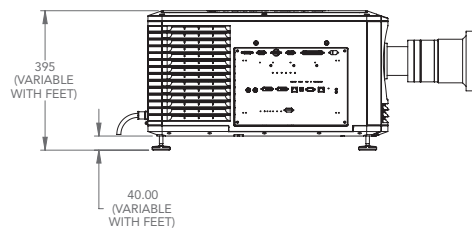
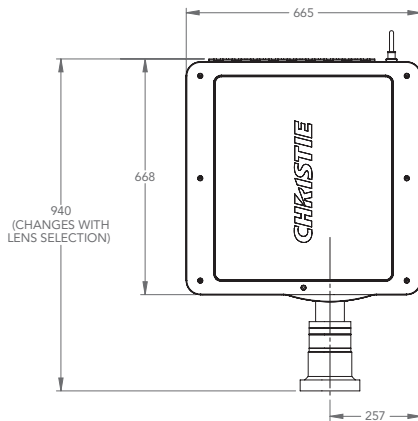

### Specifications CP2000-M

|             |  |
|-------------|--|
| Dimensions  | • (L x W x H) 25 x 25 x 12"  |
| weight      | • 96 lb  |
| Lenses      |  |
| zoom        | • 1.05:1 • 1.30-1.75:1 • 1.39-1.9:1 • 1.5-2.2:1 • 1.75-2.40:1 • 1.9-3.0:1 • 2.40-3.90:1 • 3.90-6.52:1                            |
| optional    | • 1.25x Anamorphic Lens • 1.26x Wide Converter Lens<br>(Use of the Anamorphic or Wide Converter Lens requires the CP2000-M MALM) |
| Screen size | • <35 ft (45 ft max)   |



## CP2000-ZX

Designed for ease of use and maximum reliability with mid-sized screens, the Christie CP2000-ZX is an all-in-one Digital Cinema projection solution that is the brightest, highest performance projector with the lowest operating costs in its class. With built-in web services you can use a web browser from virtually anywhere to control the projector.

Purpose-built for exhibitors, the Christie CP2000-ZX delivers high-performance projection in a cost-effective, compact solution for flexible mounting and installation. The CP2000-ZX is built on proven and reliable 1.2" 2K DMD DLP Cinema® technology, featuring a contrast ratio greater than 2000:1 and reproduces 35.2 trillion colors.

Featuring a universal switching power supply for the lowest ripple, maximum performance and reliability, the Christie CP2000-ZX is up to 50% smaller by volume, yet brighter than the competition. Our CP2000 ZX, SB and XB offers the only 100% DCI compliant lens solution available on the market with the use of Christie's optional Wide Converter Lens for unattended changeovers on screens with side masking.

The ergonomic design offers simplicity of use in a robust and reliable package. The lens mount design is stable and solid. With improved airflow and better cooling, the CP2000-ZX promotes longer lamp life and greater reliability than the competition.

- Easily accessible input and output panel located on the operator side of the projector
- One-piece compact design for flexible mounting and installation
- Switching lamp ballast for lowest ripple, maximum performance and reliability
- New HDCP decryption on both DVI inputs allows display of copy-protected alternate content (progressive signal)
- Flexible web-based control via tablet, PC or laptop, allowing for full control from virtually any location
- Operates with standard 2K, 3K and high performance 3K cinema lamps
- Perfect for dual projection or 3D applications due to its compact size and high light output
- Utilizes Texas Instruments proven reliable 1.2" DMD technology

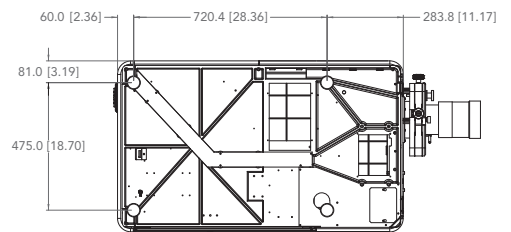
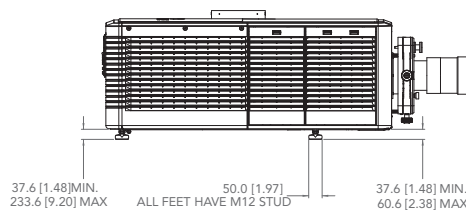
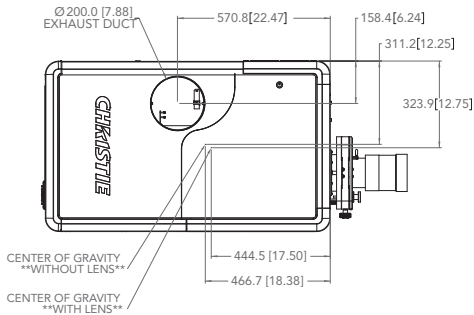

## Specifications CP2000-ZX

|             |  |
|-------------|--|
| Dimensions  | • (L x W x H) 42 x 25 x 16"  |
| weight      | • 260 lb   |
| Lenses      | • Available in High Brightness or High Contrast versions   |
| zoom        | • 1.25-1.45:1 • 1.45:1-1.8:1 • 1.8-2.4:1 • 2.2-3.0:1 • 3.0-4.3:1 • 4.3-6.0:1 • 5.5-8.5:1                           |
| optional    | • 1.26x Anamorphic Lens (requires motorized anamorphic lens mount added to front of the head)<br>• Motorized mount |
| Screen size | • <45 ft (65 ft max)   |





With almost 80% worldwide market share, Christie maintains its position as a global market leader in Digital Cinema.

According to Jack Kline, president and COO, the dramatic acceleration in the pace of global installations is a testament to Christie’s proven technology, software, and services integrated in each system. “Our unparalleled success is based on more than three-quarters of a century of experience. Quality and world-class support services remain our number one priorities as we work with exhibitors to help them make the digital transition seamlessly and revolutionize the movie-going experience.”

### CP2000-XB Splithead design

Christie’s unique split-head design revolutionizes the world of Digital Cinema projection. The separate projection head and ballast lets you put very high power in almost any space. The universal ballast gives you maximum flexibility.

Setting new standards with 2K resolution, Christie’s CP2000-XB has exceptional image quality from DLP Cinema® technology, high quality optics and 15-bit image processing for crisp, clean images with perfect color saturation and spectacular video. Based on the same

popular design as the X design, the XB now provides over 30,000 ANSI lumens. Perfect for large screens and the most demanding 3D installations! Offering the ultimate in networkability – on-board ChristieNET™ connectivity lets you control as many units as you desire through our touch panel controller from a central location.

- Separate projection head and ballast
- Adjustable lamp power – 1000-6500W
- Better than 2000:1 sequential contrast and greater than 30,000 lumens

- 6, 25, 50 and 100 foot umbilical lengths for the external ballast
- Most flexible high power solution in the industry
- Highest contrast ratio in 3-chip DLP Cinema®
- Low cost of operation
- Self-aligning lamp
- LiteLOC™ and LampLOC™
- Standard support for SNMP with optional HDCP support
- Local control though Christie’s industry standard setting Touch Panel Controller

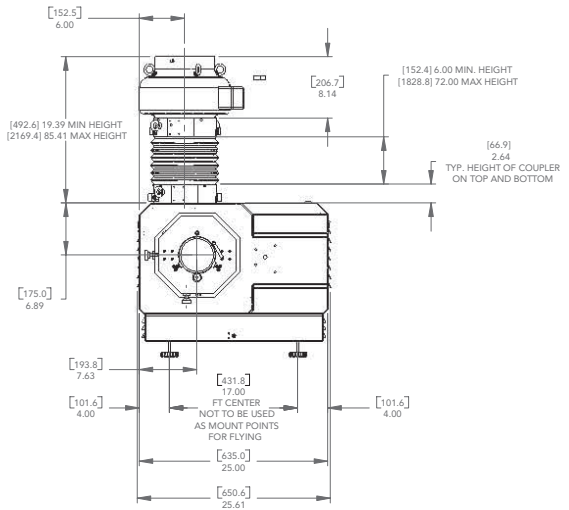
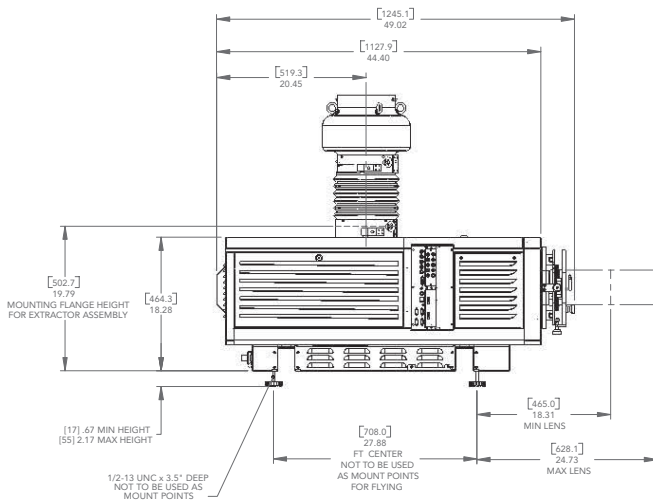

### Specifications CP2000-XB

|             |  |
|-------------|--|
| Dimensions  | • Projection head: (L x W x H) 25.6 x 49.0 x 20.5" (650 x 1250 x 520mm) • Ballast: (L x W x H) 21.3 x 17.3 x 20.9" (540 x 440 x 530mm)       |
| weight      | • Projection head: 260 lb (118.2 kg) • Ballast: 110 lb (50 kg) • Optional rigging frame: 105.4 lb (47.9 kg) with fork lift tubes and castors |
| Lenses      | • Available in High Brightness or High Contrast versions   |
| zoom        | • 1.25-1.45:1 • 1.45-1.8:1 • 1.8-2.4:1 • 2.2-3.0:1 • 3.0-4.3:1 • 4.3-6.0:1 • 5.5-8.5:1   |
| optional    | • Anamorphic Lenses (Motorized Auxiliary Lens Mount necessary for mounting of these lenses)<br>• 1.26:1 (for scope format)                   |
| Screen size | • Suitable for screens from 25-100 ft  |



### CP2000-SB

Christie's CP2000 Series projectors are the most deployed Digital Cinema projection solution in the world. Designed for exhibitors, the CP Series delivers high performance projection for a variety of screen sizes with a flexible design to accommodate future upgrades and reduce the cost of ownership.

Christie's CP Series sets a new level of performance for Digital Cinema technology. Choices in brightness and power levels offer flexibility for a variety of screen sizes in existing theater infrastructures and protects today's investments for tomorrow's development.

- Digital Cinema projectors ideally suited for large screen theaters (max 100 or 75 feet\*), post-production houses and multi-media theatrical productions  
\*(DCI spec at 100% lamp life screen gain 1.2")
- 1.2" 2k DMD™ DLP Cinema® display device
- Network connectivity to major theater automation systems and servers
- Ethernet based touch panel controller for local user interface
- Number of colors – 35 trillion
- Available with 1-7kW switching power supply

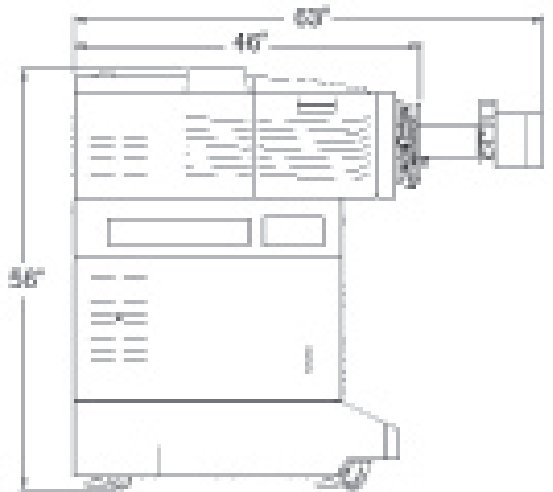
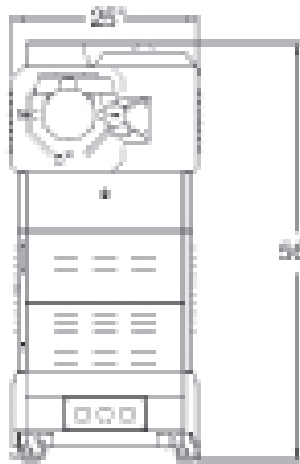
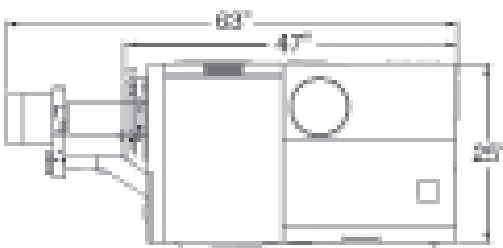

### Specifications CP2000-SB

|             |  |
|-------------|--|
| Dimensions  | • (LxWxH) 46 x 25 x 56"  |
| weight      | • CP2000S (overall system with pedestal: 505 lb (229 kg)   |
| Lenses      | • Available in High Brightness or High Contrast versions   |
| zoom        | • 1.25-1.45:1 • 1.45-1.8:1 • 1.8-2.4:1 • 2.2-3.0:1 • 3.0-4.3:1 • 4.3-6.0:1 • 5.5-8.5:1                                     |
| optional    | • Anamorphic Lenses (Motorized Auxiliary Lens Mount necessary for mounting of these lenses)<br>• 1.26:1 (for scope format) |
| Screen size | • suitable for screens from 25-100 ft  |



## Christie ACT

The Christie ACT puts control of your single screen, multiplex or entire theater chain in your hand. Christie's flexible theater automation solution and powerful open architecture can integrate fully with any end user application. With its flexibility, programmability and user-friendly GUI – the average user can easily customize tasks and events to specifically suit the needs of their own theater operation/complex.

The Christie ACT is a 2RU steel box with general purpose I/O, 2 high current (10A) relays, 10 1A relays, RS-232, RS-422, accessory power, and Ethernet.

The main user interface used for setup and operation can be accessed from any external computer's web browser.

- Completely programmable by end users via easy to use web interface
- Includes device support for all CP Series D-Cinema projectors and various audio processors
- Users can define nearly unlimited amount of "virtual actuators"
- Automation via simple GUI or advanced scripting
- Sharing scripts between multiple Christie ACTs
- Predefined scripts for supporting known devices
- Ethernet, RS-232 and RS-422
- Customized support for any product with published interface specifications



## Cine-IPM 2K

The Christie Cine-IPM 2K is the preferred choice for post-production and cinemas the world over, bringing the latest alternative content to the big screen. Using a comprehensive 10-bit image processing package, the Cine-IPM 2K takes control of the incoming signal and will display any standard output format regardless of the source. The Cine-IPM 2K accurately displays non-cinema or alternative content such as broadcast television, satellite, business presentations and HDTV sources.

The Christie Cine-IPM 2K offers image scaling, image processing and reformatting. It handles both standard and HD sources and integrates easily for use with any CP Series projectors. Additional input modules are available to accommodate virtually any digital or analog source.

- RGBHV/YPbPr: 5-BNC
- DVI-I: digital/analog
- RGB/YPbPr
- 1 composite, 1 S-video
- Dual SD/HD-SDI interface module
- Easy to reach front panel connections
- Advanced 10-bit image scaling capabilities for all sources
- Ideal for displaying alternative content
- Suitable for satellite television rebroadcast, corporate presentations
- Illuminated LCD status display
- Optional input modules for HD-SDI and SDI
- Formats virtually any incoming video source for proper display on any CP series projector
- Optional Christie Twist™ module allows blending of multiple projectors onto one screen or the automatic calibration of multiple projectors onto a single screen



## Wide Converter Lens (WCL)

The WCL achieves an accurate unattended zoom from a "flat" image format of 1.85:1 to a "scope" image format of 2.39:1. At the same time, it maintains the full resolution of the source data. Other possible solutions are either impractical, cost-prohibitive or simply do not exist. The WCL simply mounts in front of a standard prime lens and expands the image just like a zoom of 1.26X, expanding the image to effectively decrease the throw ratio. For example, it converts the zoom range of our 2.2-3.0 lens to 1.75-2.38. In essence, the WCL is a focal length adapter.

## Motorized Auxiliary Lens Mount (MALM)

The motorized auxiliary lens mount (MALM) moves the WCL out of the light path, so that it does not affect the "flat" image focus, location or performance in any way. Only lenses with the throw ratios of 1:45-1.8, 1.8-2.4, 2.2-3.0 and 3.0-4.3 are certified to work with the WCL.





## DLP Cinema® Lenses

### High Brightness Prime Lenses

(for use in commercial exhibition)

| Part number   | Description     |
|---------------|-----------------|
| 108-274101-01 | • 1.25 – 1.45:1 |
| 108-275101-01 | • 1.45 – 1.8:1  |
| 108-276101-01 | • 1.8 – 2.4:1   |
| 108-277101-01 | • 2.2 – 3.0     |
| 108-278101-01 | • 3.0 – 4.3:1   |
| 108-279101-01 | • 4.3 – 6.0:1   |
| 108-280101-01 | • 5.5 – 8.5:1   |

### High Contrast Prime Lenses

(for use in Post Production and Review Rooms)

| Part number  | Description     |
|--------------|-----------------|
| 38-809079-51 | • 1.25 – 1.45:1 |
| 38-809061-51 | • 1.45 – 1.8:1  |
| 38-809052-51 | • 1.8 – 2.4:1   |
| 38-809053-51 | • 2.2 – 3.0     |
| 38-809069-51 | • 3.0 – 4.3:1   |
| 38-809081-51 | • 4.3 – 6.0:1   |
| 38-809080-51 | • 5.5 – 8.5:1   |

(for use with CP2000-M)

| Part number   | Description     |
|---------------|-----------------|
| 108-319104-01 | • 1.05:1        |
| 108-320106-01 | • 1.30 – 1.75:1 |
| coming soon   | • 1.39 – 1.9:1  |
| coming soon   | • 1.5 – 2.2:1   |
| 108-321107-01 | • 1.75 – 2.40:1 |
| coming soon   | • 1.9 – 3.0:1   |
| 108-322108-01 | • 2.40 – 3.90:1 |
| 108-323109-01 | • 3.90 – 6.52:1 |



## Digital Cinema dimmer

Christie Digital Cinema dimmers are available in 1, 2, and 4-channel versions for both 110/115V and 220 VAC, 50/60Hz operation. Programming for each of the four presets for intensity levels and fade times are digitally controlled by the input keypad at the dimmer. The front panel has LED indicators (for both power and channel output level) and a manual panic activation/reset button (instant lights/up/full). Optional dimmer mounted circuit breakers are also available. UL and CSA listed.

- Extra large heat sink for trouble-free “cool” operation
- Easy to read display shows light level and up/down fade times
- Simple 3-button programming: Up/Down/Set
- Emergency ON/back to previous state
- Channel light level and status indicators
- Simple connections and wiring layout
- Solid state digital control system, effortless automation interfacing

| Part number        | Description                          |
|--------------------|--------------------------------------|
| 700107-019 or 020* | • DCD 2 x 2400W dimmer               |
| 700107-021 or 022* | • DCD 2 x 2400W dimmer with breakers |
| 700107-023 or 024* | • DCD 4 x 2400W dimmer               |
| 700107-026 or 027* | • DCD 4 x 2400W dimmer with breakers |

\*Note: specify 110V or 220V



## CDXL high performance short arc lamps

Christie's CDXL high performance xenon lamps are highly efficient and allow you to reduce the lamp size in your film console from the originally specified lamp while maintaining or improving brightness.

Originally designed for the CP series of Christie projectors these lamps have performed great in film consoles. For more information visit our website at [christiedigital.com](http://christiedigital.com)

## CXL short arc lamps

Proven the most reliable cinema lamps used today, Christie's CXL Xenon short arc lamps are the best commercially available option on the market with the most even light distribution - balanced like natural sunlight.

Available in 900-7500W configurations. Contact your Christie Sales Representative for the configuration best suited to meet your needs.

Today's businesses rely on increasingly complex technology to operate efficiently and maintain their competitive edge. Management is challenged more than ever before to provide the knowledge and expertise to support their company's expanding technology infrastructure – all while staying within a defined budget.



Christie draws upon 75 years' experience working with Fortune 1000 companies to deliver a portfolio of proven, reliable, managed services to support its customers' hardware and software assets. Services can vary from consultation, site selection and implementation to remote monitoring and control, preventative servicing, logistics and training. Supporting a wide array of manufacturers' projectors, visual displays, servers, switches and networking products, Christie's best-in-class

technical and field application engineers can address the most difficult infrastructure challenges.

From cinema to on-screen advertising to large group training centers, Christie Managed Services delivers the complete range of technical support to meet the unique technology needs of every organization, from a round-the-clock, 24/7 support to Pay-Per-Incident and everything in-between.

## 1. Standard Terms

Any offer made by Christie Incorporated ("Seller") to sell goods is subject to these terms and conditions, and, unless otherwise expressly agreed by Seller in writing, any different or additional terms and conditions proposed by the purchaser are hereby objected to and rejected and shall be of no effect.

## 2. Prices, Taxes and Minimum Order

2.1 Unless otherwise specified, prices are FOB point of shipment designated by the Seller. Prices do not include, and the purchaser shall pay (or reimburse Seller for), any and all excise, sales, use, personal property, inventory or similar taxes, charges or levies imposed on or in connection with the sale or use of goods sold by Seller to the purchaser or held by Seller for the purchaser pending shipment.

2.2 Price quotations are subject to change without notice.

## 3. Payment Terms

3.1 Unless otherwise specified by Company, payment terms are net thirty (30) days from the date of invoice.

## 4. Deliveries and Risk of Loss

4.1 In general, minimum of four (4) to six (6) weeks lead time after receipt of purchase order is required, and Seller shall have no liability to Buyer for late deliveries.

4.2 Delivery of goods to the purchaser shall be FOB point of shipment designated by Seller and shall be affected upon delivery to a common carrier for shipment from such location. Upon such delivery, title to and all risk of loss of or damage to the goods shall pass from Seller to the purchaser. Seller shall have no liability or responsibility in connection with claims for loss of or damage to goods incurred after delivery to the carrier, and the purchaser shall pursue all such claims directly with the carrier.

## 5. Changes, Cancellation and Returns

5.1 Orders accepted by Seller are not subject to change or cancellation by the purchaser unless Seller consents in writing and the purchaser pays to Seller an amount, not to exceed 15% of the purchase price, which covers Seller's losses (including lost profit, if any) and actual costs incurred in connection with such change or cancellation.

5.2 Seller may, but is not obligated to, accept returns of goods. Any such returns (other than returns requested by Seller in connection with warranty claims) will be limited to current goods in original cartons. Any credit issued by Seller will be for the original net purchase price of the goods less any return transportation charge paid by Seller and a restocking charge equal to 20% of the original net purchase price.

5.3 Goods may not be returned to the Seller unless the Seller consents in writing and assigns a return authorization number. Any unauthorized returns or shipping containers received from the purchaser which do not bear a return authorization number will be returned to the purchaser at the purchaser's expense. Return shipments must be prepaid, insured, and shipped at the purchaser's expense.

## 6. Force Majeure

Seller shall have no liability to the purchaser for any delay or failure in carrying out its obligations to the purchaser for reasons beyond the Seller's control, including without limitation, acts of God, war, natural disasters, labor disputes, changes in or compliance with laws, regulations or governmental policies and shortages of supplies and services. Seller may extend delivery until any such cause of delay has been removed, or at its option, cancel the undelivered portion of any order so affected without liability to the purchaser except for the return of any payment made by the purchaser to Seller with respect to any undelivered portion of the order so canceled.

## 7. Warranties and Limitation of Liability

7.1 Seller warrants to the purchaser that goods sold by the Seller to the purchaser will be free from manufacturing defects in materials and workmanship at the time the first end user purchaser initially installs such goods.

7.2 Except as expressly set forth in Section 7.1 or in writing delivered by company to the purchaser, company makes no warranties to the purchaser, written or oral, express, implied or statutory, in any manner or form whatsoever, including but not limited to any warranties of merchant ability or fitness for any particular use or purpose, which are hereby expressly disclaimed.

7.3 The warranty set forth in Section 7.1 does not apply to goods which have been subject to abuse, misuse, neglect, improper installation or alteration (other than Seller or its authorized representatives) after delivery to the carrier for shipment to the purchaser. Seller makes no warranty as to the useful life of the goods. At Seller's request, the purchaser shall return goods to Seller at its Cypress, California offices for verification that the warranty set forth in Section 7.1 of this Agreement, as limited by this Section 7.3, is applicable. Any such returns are subject to the provisions of Section 5.3.

7.4 In the event Seller determines that the warranty set forth in Section 7.1 as limited by Section 7.3, is applicable to any goods, Seller shall, as the purchaser's sole remedy, replace, or at Seller's sole option, issue to the purchaser a credit for an amount not to exceed the original purchase price paid by the purchaser to Seller for the affected goods. Seller

shall have no liability with respect to warranty claims made by the purchaser more than 12 months from Seller's sale of goods or maximum 24 months from Seller's sale of the goods for SLC Console only. In no event shall Seller be liable to the purchaser for any special, incidental or consequential damages.

## 8. Infringement

8.1 Subject to Section 8.2, Seller shall indemnify and hold the purchaser harmless from any claims that goods sold by the Seller to the purchaser infringe on the patent or other proprietary rights of third parties, except that Seller shall have no liability under this provision unless the purchaser gives to the Seller prompt written notice of any such claim, full authority to settle, compromise or defend any such claim, and full cooperation in connection therewith. In the event the purchaser notifies the Seller of any such infringement claims, Seller shall at its option (a) defend or settle such claims, (b) procure for the purchaser the right to use the goods, (c) substitute non-infringing goods or (d) accept the return of the product and refund the purchase price less appropriate deductions in the event the goods are not returned in the condition in which sold.

8.2 The purchaser shall indemnify and hold Seller harmless from any claims that goods sold by Seller to purchaser in accordance with specifications furnished by purchaser infringe on the patent or other proprietary rights of third parties.

## 9. Designs and Trade Secrets

Any drawings, data, designs, or other technical information supplied by Seller to the purchaser in connection with the sale of any goods shall remain Seller's property and shall be held in confidence by the purchaser, and the same shall not be reproduced or disclosed to others without Seller's prior written consent.

## 10. Miscellaneous

10.1 The purchaser's rights; duties and claims under these terms and conditions may not be assigned, transferred or delegated without prior written consent of Seller in each instance.

10.2 These terms and conditions and any contract of sales between the Seller and the purchaser shall be governed by the laws of the State of California.

10.3 If any provision contained in these terms and conditions or any contract of sale between the Seller and the purchaser or any portion of any such provision is held to be unenforceable or invalid, the remaining provisions and portions shall nevertheless be carried into effect.

10.4 The headings contained in these items and conditions are for convenience only and do not in any way interpret, limit or amplify the scope, extent or intent of any of the provisions.



### Corporate offices

USA – Cypress  
ph: 714-236-8610  
Canada – Kitchener  
ph: 519-744-8005

### Worldwide offices

United Kingdom  
ph: +44 118 977 8000  
Germany  
ph: +49 2161 664540  
France  
ph: +33 (0) 1 41 21 44 04

Hungary/Eastern Europe  
ph: +36 (0) 1 47 48 100  
Singapore  
ph: +65 6877 8737  
Shanghai  
ph: +86 21 6278 7708

Beijing  
ph: +86 10 6561 0240  
Korea  
ph: +82 2 702 1601  
Japan  
ph: +81 3 3599 7481



For the most current specification information, please visit [www.christiedigital.com](http://www.christiedigital.com)

 Copyright 2008 Christie Digital Systems, Inc. All rights reserved. All brand names and product names are trademarks, registered trademarks or tradenames of their respective holders. Canadian manufacturing facility is ISO 9001 and 14001 certified. Performance specifications are typical. Due to constant research, specifications are subject to change without notice. Printed in Canada on recycled paper. 2317 Feb 08

**CHRISTIE®**