

TO: TOKIWA CO., LTD.

**SPECIFICATION SHEET**

TYPE: XENON SHORT ARC LAMP

MODEL: YXL-1600C13

AGREED BY  
[ TOKIWA CO., LTD. ]

DATE:                   /                   /                   \_\_\_\_\_

APPROVED BY                   H. Fujita                  

CHECKED BY                   T. Akamatsu                  

ISSUED BY                   Tatsuya AOTA                  

YUMEX INC.

DATE :       27-Dec-16

SPEC No. :   YYT250254

**【Confidential】**

# RECORD

TYPE : XENON SHORT ARC LAMP

MODEL : YXL-1600C13

| DATE      | NOTE       | CHECK |
|-----------|------------|-------|
| 27-Dec-16 | New issue. |       |
|           |            |       |
|           |            |       |
|           |            |       |
|           |            |       |
|           |            |       |
|           |            |       |
|           |            |       |
|           |            |       |
|           |            |       |
|           |            |       |
|           |            |       |
|           |            |       |
|           |            |       |
|           |            |       |
|           |            |       |
|           |            |       |
|           |            |       |

YUMEX INC.

**【Confidential】**

# Specification

Date : 27-Dec-16

1. Appreciation of this specification

This specification is provided for Xenon Short Arc Lamp, model YXL-1600C13 which is supplied from YUMEX INC.

2. Type of the Lamp

Xenon Short Arc Lamp

3. Model No. of the Lamp

YXL-1600C13

4. Application of the Lamp

Light Source for Digital Cinema Projector

5. Structure and dimension

- 1) The Lamp is a Double-Ended D.C. type discharge lamp which has the anode, cathode and quartz glass arc bulb sealed at both ends.
- 2) The appearance, dimensions and weight of the Lamp are specified in the drawing No.EDWX159.

6. Electrical characteristics

| Rated Lamp Voltage | Rated Lamp Current | Rated Lamp Wattage |
|--------------------|--------------------|--------------------|
| 22.2±2 V           | 72±1 A             | 1600 W             |

\* The above is initially value.

7. Operation conditions

7-1. Lamp wattage

The Lamp should be operated within the Item 6 as above.

7-2. Burning position

The Lamp should be operated only in the horizontal position with  $\pm 5^\circ$ .

7-3. Cooling

The Lamp should be cooled to keep the conditions in Fig. 1 during the operation. The cooling conditions below shall be subject to the specification of the machine.

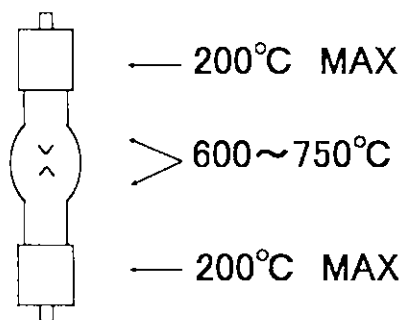

Fig. 1 Temperature condition for each portion of the Lamp for cooling

7-4. Warning the installation and uninstillation

- 1) One base of the Lamp should be fixed and the other end should not be fixed.
- 2) The Lamp should be installed without twist and stress from outside.

7-5. Lighting power supply

Use the power-supply unit input by 1600W.

7-6. Warranty

One year from delivery date.

The lamp is not guaranteed after the term of guarantee expire.

7-7. Use environment

| Temperature | Humidity    | Pressure    | Others  |
|-------------|-------------|-------------|---------|
| +10 ~ +40°C | 10 ~ 80% RH | Atmospheric | Nothing |

8. Storage conditions

| Temperature  | Humidity    | Pressure    | Others         |
|--------------|-------------|-------------|----------------|
| - 40 ~ +70°C | 10 ~ 80% RH | Atmospheric | Non condensing |

9. Optical characteristics

9-1. Initial illumination

Total luminous flux · · · 55000lm

We lighted it by integrating sphere and mesured by CL-200 made by KONICA MINOLTA.

\* The measurement method shall be based on YUMEX rule.

9-2. Spectral Characteristics

Fig. 2 shows the Spectral Characteristics measured at 1 meter distance in horizontal direction from the center of the Lamp when the Lamp is operated at Rated Lamp Wattage.

The data in Fig. 2 is for reference only. The actual characteristics is slightly affected by the circumstances where the Lamp is operated.

※Refer to Fig.2 to next page.

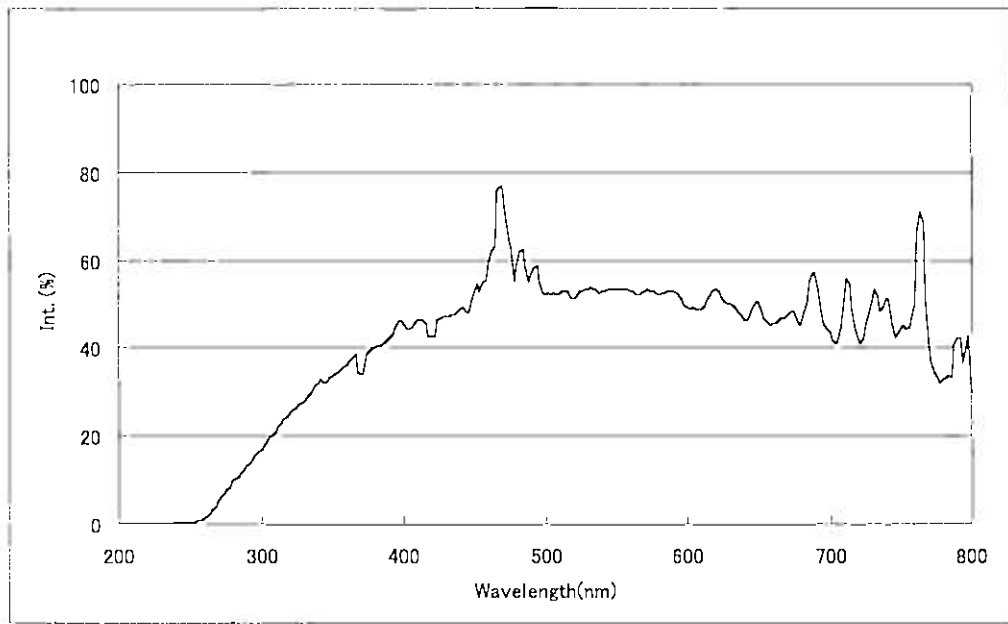

Fig. 2 YXL-1600C13 Spectral Distribution Map

10. Warranty for Lamp life

10-1. Definition of Life-End

The Lamp should be judged as Life-End when either of the following 1), 2) or 3) occurs under continuous operation with the conditions specified in Item 7.

- 1) The intensity from the Lamp itself comes down to 50% of the initial value (Called "Decrement")
- 2) The Lamp becomes inoperable within 3000 hours of operation. (Called "Inoperative")
- 3) Explosion of the Lamp under the correct operation with the conditions specified in Item 7 within 3000 hours of operation. (Called "Explosion")

\* The measurement method of the illumination and stability shall be based on YUMEX rule.

10-2. Life warranty and compensation

The Lamp should be replaced with free of charge or determined its compensation by Formula 1. if the Lamp reach "Life-End" as specified in Item 10-1 within the operated hours specified in the Table 1 under the correct operation with the conditions specified in Item 7.

Table 1 Life Warranty by Life-End Mode

| Life-End Mode | Decrement               | Inoperative             | Explosion               |
|---------------|-------------------------|-------------------------|-------------------------|
| Life Warranty | 3000 (h) ※ <sup>1</sup> | 3000 (h) ※ <sup>1</sup> | 3000 (h) ※ <sup>1</sup> |

※<sup>1</sup> Formula1. Life Warranty by Operated Hours

$$\left( \frac{3000 \text{ (h)} - \text{Operated Hours(h)}}{3000 \text{ (h)}} \right) \times \text{Sales Price}$$

10-3. Not covered under warranty

- 1) The defect is judged to be caused by a mistake by the handling of the Lamp.
- 2) The peculiarity is not discovered from the lamp, the Lamp is judged to be able to use.

10-4. Coverage

We YUMEX should compensate for whole or some parts of the damage which is occurred by the defect or fault of the Lamp.

In this regard, however we should not compensate you if the following case.

- 1) The cause of the damage is not to obeyed the conditions as mentioned in this specifications.
- 2) No notice within one week after the damage occurs.
- 3) No offer of the broken Lamp, documents and data to specify the cause of the damage.
- 4) No offer of the documents and composition letter to assess and fix of the damages.
- 5) All damage is occurred by the unperformance of the Lamp such as the "Decrement" or "Inoperative".  
(We compensate by gratuitous repair or the exchange of the new Lamp.)
- 6) The damage by the defect that occurs over the settled life warranty in Item 10-2.
- 7) All damage that occurs indirectly such as a loss by the suspension of business, passive damages and opportunity loss.
- 8) The damage by the Fire and/or natural disaster such as earthquake, etc.

11. Cautions in handling the Lamp

11-1. Cautions after taking off the Lamp from the Lamp case.

- 1) Do not make any hit the Lamp, to stress from outside such as twisting and bending and hurt to the Lamp.  
(It may cause the damage and the explosion of Lamp.)
- 2) To handling the Lamp, be sure to wear face shield (which can be protected including neck), protection gloves and thick long sleeve clothes.  
(It may cause the injury when the damage and the explosion happened.)
- 3) Do not apply vibration and shock to the Lamp. (It may cause the damage or short life.)
- 4) Do not touch the lamp with bare hands directly. If the Lamp is stained, to wipe it with clean cloth which is soaked alcohol. (It may cause the damage or short life.)
- 5) Not throwing away an exclusive Lamp box for safekeeping or using for the disposal of the Lamp.
- 6) As the lamp is filled with high-pressure gas, do not remove its cover before lighting.

11-2. Caution in installation the Lamp

- 1) Install the Lamp with instruction of "Cautions after taking off the Lamp from the Lamp case." in Item 11-1.
- 2) Install the Lamp to machine after switching off the machine to be sure.  
(It may cause the damage or short life.)
- 3) Install Anode side and Cathode side in the proper position as specified.  
(It may cause the damage or short life.)
- 4) Do not make electrical connection before confirming the electrical contacts have no rust, no burnt-surface, no color-change, etc.
- 5) To be sure to connect the Lamp or the lead-wire to the machine without any stress such as twisting and bending.
- 6) Connect surely (without loose) the electrical contacts of the Lamp to the machine (the terminal portion of the operating equipment).

- 11-3. Caution in the Operation (Lighting)
- 1) Never receive the radiation from the Lamp directly with bare eyes or skins, as the Lamp produces high intensity radiation including the harmful Ultra-Violet rays to human's body.  
(It may cause the eye hurt and visually-impaired.)
  - 2) The Lamp should be operated in the equipment specially designed to use the Lamp and with understanding about the accompanying instruction.  
Do not use the Lamp with other application.  
(It may cause the explosion or the machine trouble.)
  - 3) Make sure the door of the lamp house in the equipment is closed before operation.
  - 4) The Lamp house should be the special structure which a piece of glass is not scatted by the explosion. (It may cause the Fire.)
  - 5) Do not use the Lamp with a flammable atmosphere such as thinner etc.  
In addition, do not close to the paper and cloth which is easy to burn to a lamp, and do not overturn. (It may cause of the Fire or explosion)
  - 6) Take at least 10 minutes interval before re-starting operation after switching off.
  - 7) Do not use the Lamp which operated over the warranty. Exchange to new one.  
(It may cause the explosion .)
- 11-4. Caution in the explosion or breakage
- 1) Take refuge from the place to have possibilities to suck the mercury which is leaked when the Lamp breakage or explodes during lighting.  
In addition, ventilate more than 30 minutes.
- 11-5. Caution after Operation
- 1) Do not open the door of the lamp house in the operating equipment in at least 10 minutes after switching off. (It may cause the injury because the pressure of filled gas in the bulb is very high during and after the lighting.)
  - 2) After lights out, do not touch the lamp till a lamp gets cold enough.  
(It may because the burn injury.)
  - 3) After lights out, do not close to the paper and cloth which is easy to burn to a lamp, and do not overturn. (It may cause of the Fire.)
- 11-6. Caution in taking off the Lamp
- 1) Taking off the Lamp with instruction of "Cautions after taking off the Lamp from the Lamp case." in Item 11-2.
  - 2) Install the Lamp to machine after switching off the machine to be sure.  
(It may cause the damage or short life.)
  - 3) After lights out, do not touch the lamp till a lamp gets cold enough.
- 11-7. Keeping the Lamp (including the operated Lamp)
- Put the Lamp in an exclusive Lamp box with show the Lamp model and serial number on the face in the upper side and keep it as pushing over sideways.
- 11-8. Carrying the Lamp
- The Lamp should be in an exclusive Lamp box when the carrying.  
(It may cause the injury if the breakage and explosion.)

11-9. Checking the equipment and the Lamp

The followings should be checked.

1) The Lamp

The appearance of terminal and base : Make sure there is no rust, no burnt-surface,  
no color-change, etc.

Operated hours : Checking the operated hours that it is not past guarantee life time.

2) The machine

Appearance of electrical connection portion : Make sure there is no rust, no burnt-surface,  
no color-change, etc.

Appearance of Insulating portion : Make sure there is no burnt-surface, no color-change, etc.

Electrical connection portion : Make sure they are connected surely without loose.

Cooling portion : Make sure the cooling fan is working properly.

Note : Confirm the instruction manual of the device.

11-10. Transportation of the Lamp

1) In case that the Lamp is packaged and transported again, the Lamp should be packed in an exclusive Lamp box and the box for transportation in the same manner as the ones when the Lamp is delivered.

2) The exclusive Lamp box should be placed into the durable box for transportation.

(The face of exclusive Lamp box with "UP" marking should be kept up during the transportation.)

Sufficient cushion materials should be put in between the exclusive Lamp case and the box for transportation.

3) During transportation of machine, the Lamp should be take off from the machine.

12. Returning of the Lamp

1) The Lamp in need of the judgment of Good or Defective should be not broken and returned to supplier carefully in the same manner as the ones when the Lamp is delivered.

(YUMEX don't bear the expense at the time of the return.)

2) In case that the Lamp should be returned due to the defect, the "Check list for defect inspection (lamp)" as attachment must be described the details of accident including operated hours etc. and must be sent together with the Lamp will be returned.

13. Disposal of the Lamp after use

The Lamp after use should be disposed in the proper manner.

14. Note

1) The special note which is not shown on the specification and drawing is decided by agreement in each time with both should be added a postscript to Item 15.

2) The revision and abolition of this specification should be decided with agreement of both.

15. Special Note

No.



16. Packing for Transportation

16-1. Packing Material

|     | Kind                        | QTY               | Material          | Standard                          |
|-----|-----------------------------|-------------------|-------------------|-----------------------------------|
| (A) | Packing Box                 | S: 1-16<br>L: 1-9 | Cardboard         | 90*100*445 (S)<br>115*135*510 (L) |
| (B) | Transportation Box(Outside) | 1                 | Cardboard         | 560*475*710<br>or 440*350*590     |
| (C) | Cushioning(1)               | Proper Quantity   | Polystyrene resin | "S" shaped Cushioning             |
| (D) | Cushioning(2)               | 2                 | Urethane foam     | -                                 |
| (E) | UP Seal                     | 2                 | Paper             | -                                 |
| (F) | FRAGILE Seal                | 2                 | Paper             | -                                 |
| (G) | Adhesive Tape               | 4                 | Cloth             | -                                 |

16-2. How to pack

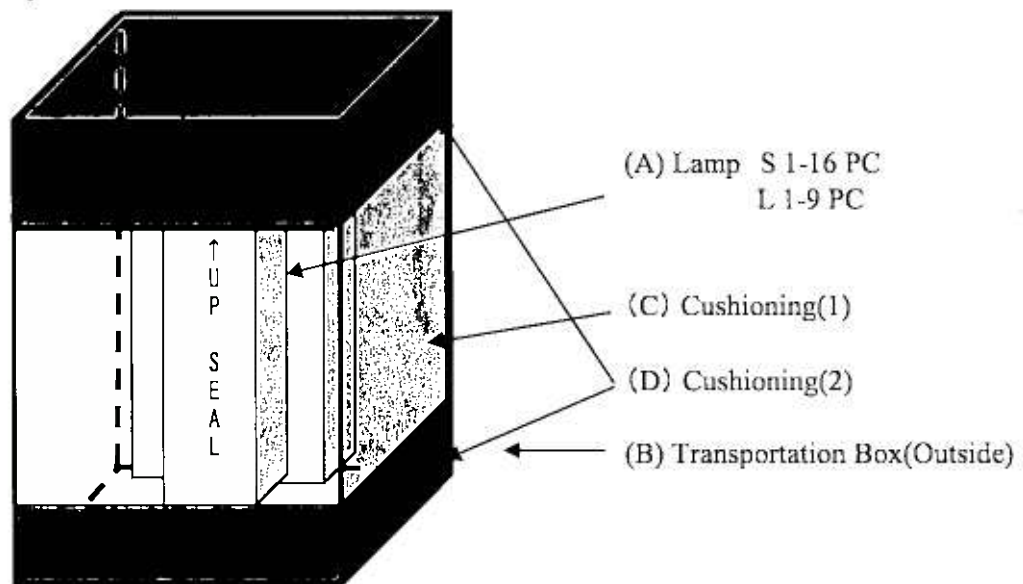

16-3. Sealing

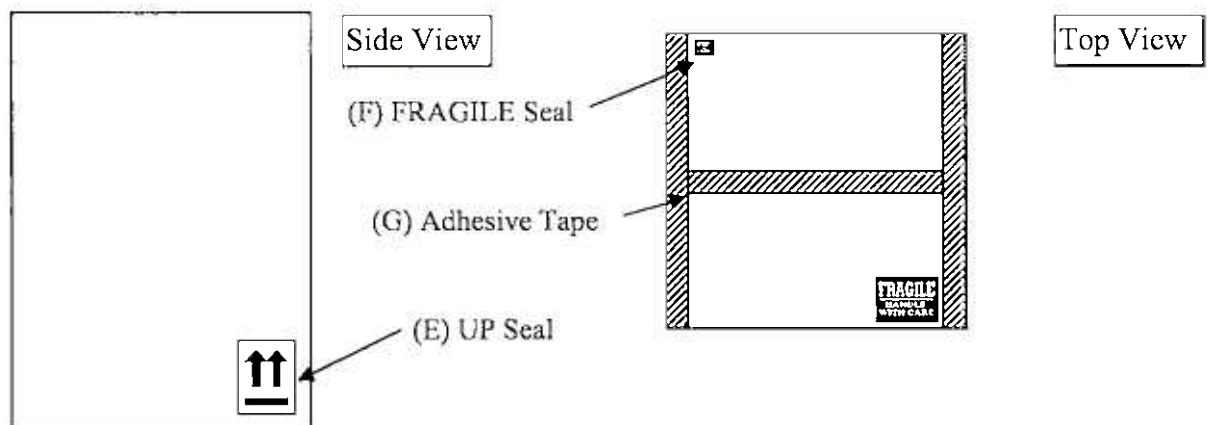

| ELECTRICAL CHARACTERISTICS |                |
|----------------------------|----------------|
| RATED POWER                | 1600 W         |
| RATED CURRENT              | 72 ±1 A        |
| RATED VOLTAGE              | 22.2 ±2 V      |
| BURNING CONDITIONS         |                |
| BURNING POSITIONS          | H ±5°          |
| BASE TEMPERATURE           | 200°C MAX.     |
| REMARKS                    |                |
| LAMP TYPE                  | OZONELESS      |
| WEIGHT                     | APPROX. 0.5 kg |

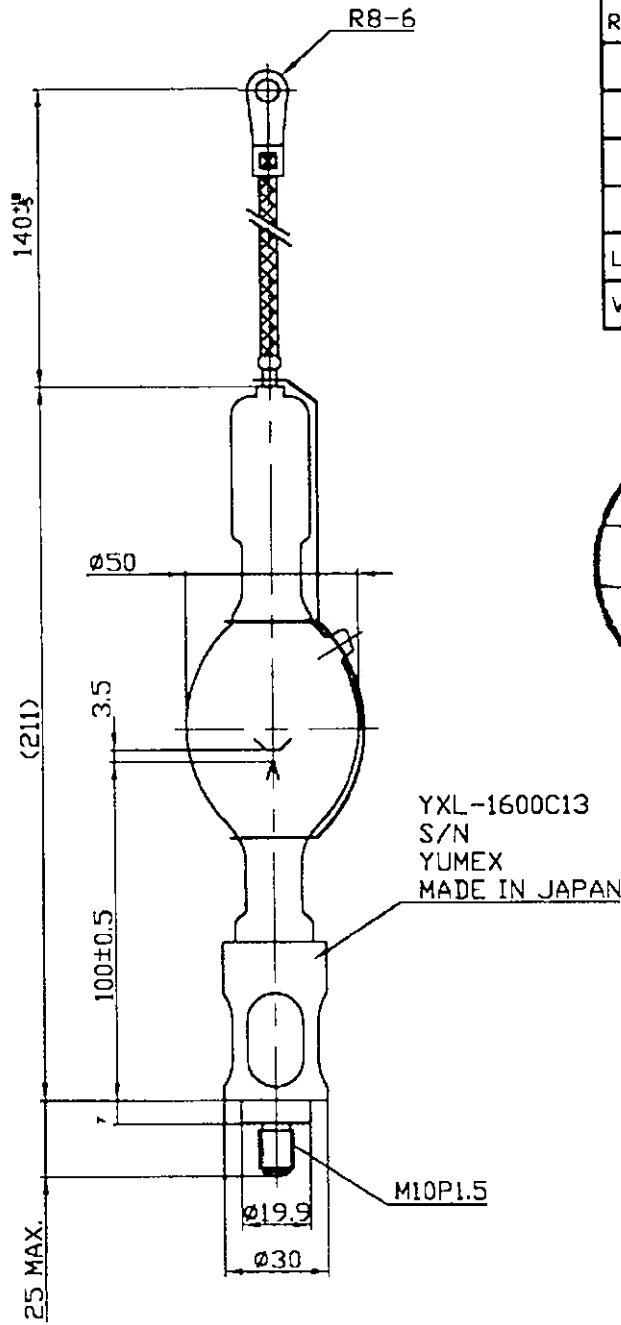

DIMENSIONS:mm

|   |                   |                |                                     |            |                |                   |  |  |   |  |                   |  |   |  |  |  |             |                   |                  |          |
|---|-------------------|----------------|-------------------------------------|------------|----------------|-------------------|--|--|---|--|-------------------|--|---|--|--|--|-------------|-------------------|------------------|----------|
| <table border="1"> <tr><td>△</td><td></td><td></td><td></td></tr> <tr><td>△</td><td></td><td></td><td></td></tr> <tr><td>△</td><td></td><td></td><td></td></tr> <tr><td>△</td><td></td><td></td><td></td></tr> </table> | △                 |                |                                     |            | △              |                   |  |  | △ |  |                   |  | △ |  |  |  | 作成日<br>DATE | 承認<br>APPROVED BY | 検閲<br>CHECKED BY | 型式 MODEL |
|   | △                 |                |                                     |            |                |                   |  |  |   |  |                   |  |   |  |  |  |             |                   |                  |          |
|   | △                 |                |                                     |            |                |                   |  |  |   |  |                   |  |   |  |  |  |             |                   |                  |          |
|   | △                 |                |                                     |            |                |                   |  |  |   |  |                   |  |   |  |  |  |             |                   |                  |          |
| △   |                   |                |                                     |            |                |                   |  |  |   |  |                   |  |   |  |  |  |             |                   |                  |          |
| 2015<br>0205  | FUJITA            | NAKAGOE        | YXL-1600C13                         |            |                |                   |  |  |   |  |                   |  |   |  |  |  |             |                   |                  |          |
| 尺取<br>SCALE   | 設計<br>DESIGNED BY | 製図<br>DRAWN BY | 名称 TITLE                            |            |                |                   |  |  |   |  |                   |  |   |  |  |  |             |                   |                  |          |
| 1:2   | ADTA              | ADTA           | -                                   |            |                |                   |  |  |   |  |                   |  |   |  |  |  |             |                   |                  |          |
| <table border="1"> <tr> <td>図章<br/>MARK</td> <td>日付<br/>DATE</td> <td>記号<br/>CONTENTS</td> <td>変更者<br/>REVISED BY</td> </tr> <tr> <td></td> <td></td> <td></td> <td></td> </tr> </table>                                |                   |                | 図章<br>MARK                          | 日付<br>DATE | 記号<br>CONTENTS | 変更者<br>REVISED BY |  |  |   |  | 社名<br>DRAWING NO. |  |   |  |  |  |             |                   |                  |          |
| 図章<br>MARK  | 日付<br>DATE        | 記号<br>CONTENTS | 変更者<br>REVISED BY                   |            |                |                   |  |  |   |  |                   |  |   |  |  |  |             |                   |                  |          |
|   |                   |                |                                     |            |                |                   |  |  |   |  |                   |  |   |  |  |  |             |                   |                  |          |
| 変更 REVISIONS  |                   |                | 株式会社 ユメックス<br>YUMEX INC,<br>EDWX159 |            |                |                   |  |  |   |  |                   |  |   |  |  |  |             |                   |                  |          |

SIZE : A4R

## Check list for defect inspection (lamp)

DATE: \_\_\_\_\_

\*Please attach this document with defect lamp and return it to us.

NAME: \_\_\_\_\_

### Customer information

|                           |     |     |         |      |        |
|---------------------------|-----|-----|---------|------|--------|
| Customer                  |     |     |         |      |        |
| Occupation (please check) | PCB | LCD | PDP     | SEMI | Others |
| Area                      |     |     | Country |      |        |

### Using conditions

|                            |            |                |                       |            |  |
|----------------------------|------------|----------------|-----------------------|------------|--|
| Lamp Model                 |            |                | S/N                   |            |  |
| Electric Properties        | V          | A              | *Data of pre-shipment |            |  |
| Wavelength                 | nm         |                | Control method        |            |  |
| Illuminance Meter maker    |            |                | Meter type            |            |  |
| Intensity of primary stage |            |                | Requir Intensity      | (mimimum)  |  |
| Timing of exchnage lamp    |            |                |                       |            |  |
| Using condition            | Continuity | Operating Time | hours/day (           | OFF time)  |  |
|                            | Blinking   | ON             |                       | OFF        |  |
|                            |            | Operating Time | hours/day (           | hours OFF) |  |
| Warranty                   | hours      |                | shot                  |            |  |
| Operated Hours             | hours      |                | shot                  |            |  |
| Details for defect lamp    |            |                |                       |            |  |

### Unit information

|              |  |       |  |
|--------------|--|-------|--|
| Manufacturer |  | Type  |  |
| Application  |  | Usage |  |
| Modification |  |       |  |
| Special Note |  |       |  |

### Power supply(Ballast)

|              |  |      |  |
|--------------|--|------|--|
| Manufacturer |  | Type |  |
| Special Note |  |      |  |

PREPARED